



Yun-Fai Chris Lau
Wai-Yee Chan
editors

The  Chromosome
and
Male Germ Cell Biology
in Health and Diseases



The Chromosome
and
Male Germ Cell Biology
in Health and Diseases

This page intentionally left blank

Editors

Yun-Fai

University of California, USA

Wai-Yee Chan

Georgetown University, USA

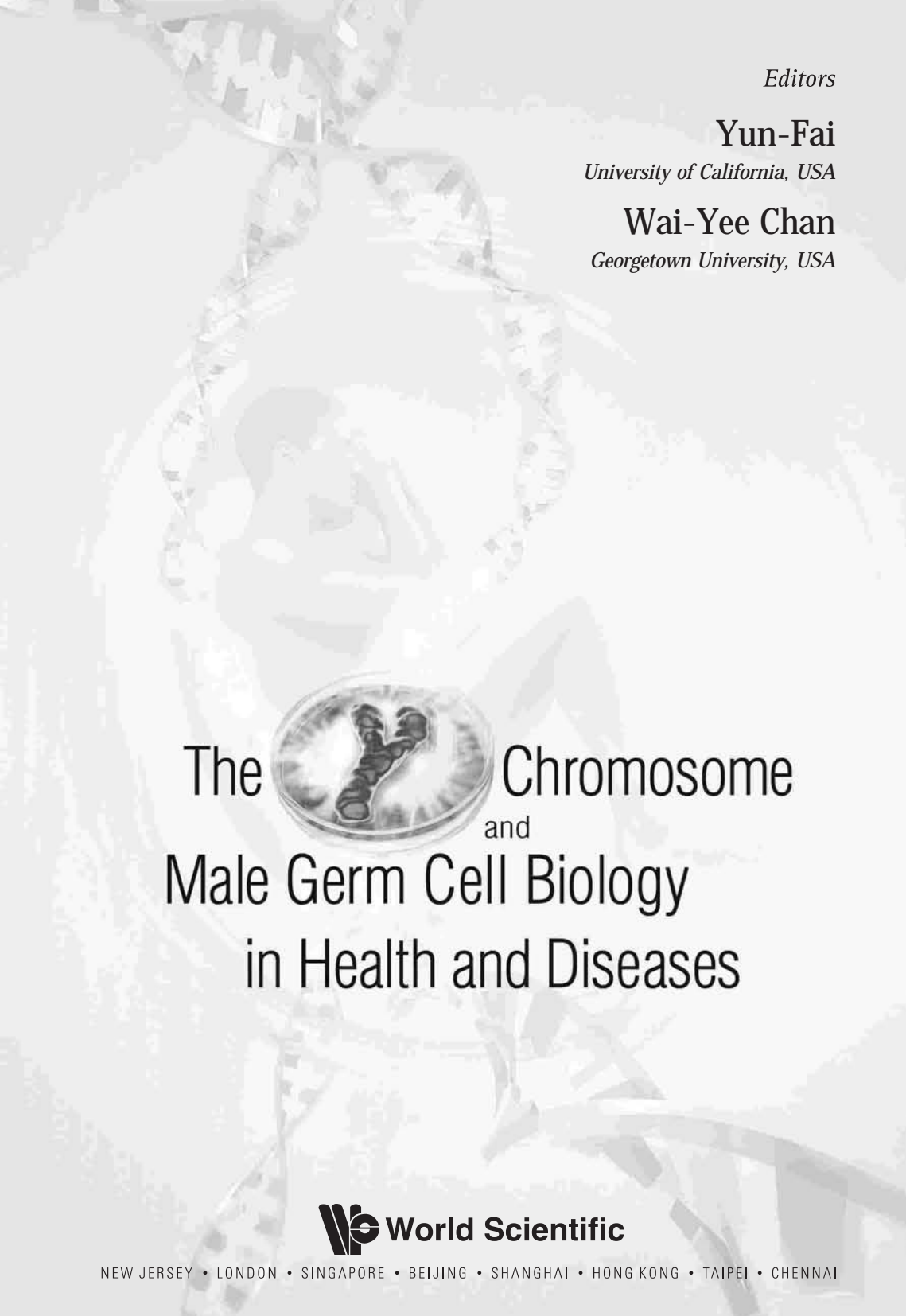

The  Chromosome
and
Male Germ Cell Biology
in Health and Diseases

 **World Scientific**

NEW JERSEY • LONDON • SINGAPORE • BEIJING • SHANGHAI • HONG KONG • TAIPEI • CHENNAI

Published by

World Scientific Publishing Co. Pte. Ltd.

5 Toh Tuck Link, Singapore 596224

USA office: 27 Warren Street, Suite 401-402, Hackensack, NJ 07601

UK office: 57 Shelton Street, Covent Garden, London WC2H 9HE

British Library Cataloguing-in-Publication Data

A catalogue record for this book is available from the British Library.

**THE Y CHROMOSOME AND MALE GERM CELL BIOLOGY
IN HEALTH AND DISEASES**

Copyright © 2007 by World Scientific Publishing Co. Pte. Ltd.

All rights reserved. This book, or parts thereof, may not be reproduced in any form or by any means, electronic or mechanical, including photocopying, recording or any information storage and retrieval system now known or to be invented, without written permission from the Publisher.

For photocopying of material in this volume, please pay a copying fee through the Copyright Clearance Center, Inc., 222 Rosewood Drive, Danvers, MA 01923, USA. In this case permission to photocopy is not required from the publisher.

ISBN-13 978-981-270-374-3

ISBN-10 981-270-374-8

Typeset by Stallion Press

Email: enquiries@stallionpress.com

Printed in Singapore.

FOREWORD

Owen M. Rennert

Scientific Director,

National Institute of Child Health and Human Development,

National Institutes of Health

For the real amazement, if you wish to be amazed, is this process. You start out as a single cell derived from the coupling of a sperm and an egg; this divides into two, then four, then eight, and so on, and at a certain stage there emerges a single cell which has as all its progeny the human brain. The mere existence of such a cell should be one of the great astonishments of the earth. People ought to be walking around all day, all through their waking hours calling to each other in endless wonderment, talking of nothing except that cell.³

This book focuses on the development of one progenitor in the “amazing process” described so eloquently by Lewis Thomas — the biology of spermatogenesis. It examines a model stem cell system, and attempts to formulate a series of fundamental questions:

1. What are the genetic regulatory events that determine progression from a primordial (stem) cell that curtails cell proliferation and initiates a process of differentiation that gives rise to spermatozoa?
2. What is the genetic machinery operative during meiosis and mitosis?
3. What are some of the trophic factors within the cell’s environment/niche that initiate or drive this process?
4. What are the temporal changes in the transcriptome and proteome that regulate the process of spermatogenesis?
5. How do these biological processes modulate or affect reproduction and malignant transformation, and can one develop new strategies based on this new information to apply to the management of reproductive failure, etc.?

³Lewis Thomas (1979), cited in Scott Gilbert (2006), *Developmental Biology*, Sinauer Associates Inc., Sunderland, MA, p. 152.

The first six chapters of this volume focus on Y chromosome-specific factors/functions, and on the role of the X chromosome and some of the autosomes during spermatogenesis. The investigators present data on both normal spermatogenesis as well as infertility associated with arrested/defective spermatogenesis.

Chapters 7 through 9 present new data and highlight the functions of various growth factors and initiation factors, and the mechanisms of transcriptional regulation that modify or control the process of spermatogenesis. Chapters 10–12 discuss the application of new technologies to study spermatogenesis: *in vitro* spermatogonial stem cell models, transplantation of germ cells and testicular tissue, and novel approaches for initiation of fertilization in mammals.

The final two chapters present the results of investigations of testicular germ cell tumors and the origin of germ cell neoplasia. They identify potential gene targets that modulate these processes, and discuss the interaction of gene polymorphisms with the environment and their potential importance in neoplastic transformation.

The research presented in this book focuses on one central theme — those factors that regulate cell fate; how a cell's destiny either to proliferate or to differentiate is determined. Spermatogenesis may serve as a model system to investigate this fundamental phenomenon.

“Research is to see what everybody else has seen, and to think what nobody else has thought.”

Albert Szent-Györgi (1893–1986)

CONTENTS

	Foreword	v
	<i>Owen M. Rennert</i>	
Chapter 1	The roles of mouse Y chromosome genes in spermatogenesis	1
	<i>Paul S. Burgoyne and Michael J. Mitchell</i>	
Chapter 2	Male meiotic sex chromosome inactivation and meiotic silencing	27
	<i>James M. A. Turner and Paul S. Burgoyne</i>	
Chapter 3	Insights into <i>SRY</i> action from sex reversal mutations	47
	<i>Melissa I. Stahle, Pascal Bernard, and Vincent R. Harley</i>	
Chapter 4	The <i>TSPY</i> gene family	73
	<i>Yun-Fai Chris Lau, Tatsuo Kido, and Yunmin Li</i>	
Chapter 5	Structure and function of AZFa locus in human spermatogenesis	91
	<i>Peter H. Vogt, Hans-Juergen Ditton, Christine Kamp, and Jutta Zimmer</i>	
Chapter 6	<i>RBMV</i> and <i>DAZ</i> in spermatogenesis	127
	<i>Pauline Yen</i>	
Chapter 7	Neurotrophic factors in the development of the postnatal male germ line	149
	<i>Marie-Claude Hofmann and Laura Braydich-Stolle</i>	

Chapter 8	Dickkopf-like 1 — a protein unique to mammals that is associated both with formation of trophoblast stem cells and with spermatogenesis	185
	<i>Matthew J. Kohn, Kotaro J. Kaneko, Rieko Yagi, Eveline S. Litscher, Paul M. Wassarman, and Melvin L. DePamphilis</i>	
Chapter 9	Antisense transcription in developing male germ cells.....	201
	<i>Wai-Yee Chan, Shao-Ming Wu, Lisa Rusczyk, Tin-Lap Lee, and Owen M. Rennert</i>	
Chapter 10	The spermatogonial stem cell model.....	221
	<i>Martin Dym and Zuping He</i>	
Chapter 11	Transplantation of germ cells and testis tissue.....	235
	<i>Ina Dobrinski</i>	
Chapter 12	Orthodox and unorthodox ways to initiate fertilization and development in mammals.....	255
	<i>Ryuzo Yanagimachi</i>	
Chapter 13	Pathogenesis of testicular germ cell tumors.....	263
	<i>Leendert H. J. Looijenga</i>	
Chapter 14	Origin of testicular germ cell neoplasia: the role of sex chromosomes	289
	<i>Ewa Rajpert-De Meyts, Anne Marie Ottesen, Christina Hoei-Hansen, Si Brask Sonne, Henrik Leffers, and Niels E. Skakkebaek</i>	
	Author Index.....	309
	Index.....	311

CHAPTER 1

THE ROLES OF MOUSE Y CHROMOSOME GENES IN SPERMATOGENESIS

Paul S. Burgoyne* and Michael J. Mitchell†

**MRC National Institute for Medical Research,
Division of Developmental Genetics, The Ridgeway,
Mill Hill, London NW7 1AA, UK*

*†Inserm U491, Faculté de Médecine,
27 bd Jean Moulin,
13385 Marseille, France*

Because the mammalian Y chromosome is largely isolated from the reciprocal recombination with a paired homolog that has underpinned the mapping and positional cloning of genes elsewhere in the genome, the identification of Y gene functions separable from that of testis determination has derived primarily from deletion mapping. Evidence for a Y gene function in spermatogonial proliferation mapping to the mouse Y chromosome short arm was first obtained in 1986, and functions in spermiogenesis to the long arm in 1988 and to a second deletion interval on the short arm in 1998. Defining the gene content of the deletion intervals has been a major task. The first short arm deletion interval proved to be >900kb, and it was not until 1998 that the eight genes lying partially or completely within the interval were identified. The other two deletion intervals are much larger, and comprise regions of repetitive DNA within which there are multi-copy Y genes. Assigning the functions defined by the deletions to specific genes has proved extremely difficult because gene targeting is not an option for multi-copy genes, and has been unsuccessful for single-copy Y genes. Here, we review attempts to use transgene rescue to identify the Y gene(s) that underlies each of the deletion phenotypes. The only success has been in assigning the Y short arm gene function in spermatogonial proliferation to *Eif2s3y*. There is a closely related X-linked copy, *Eif2s3x*, which encodes a virtually identical protein (a subunit of the translation initiation factor EIF2); we have now shown that an *Eif2s3x* transgene also

rescues the spermatogonial proliferation failure. Since *Eif2s3x* escapes X inactivation and is thus expressed from both X copies, the normal expressed *Eif2* dosage is two in males and females; this suggests that the spermatogonial block in the deletion mice is due to haploinsufficiency for the EIF2 subunit. However, this still begs the question why spermatogonia are the only cells that are overtly compromised by this haploinsufficiency. Although the transgene rescue approach has so far only achieved this single success, analysis of the *Eif2* transgene rescue mice has pointed to two further functions for genes mapping to the same deletion interval as *Eif2s3y*: one in relation to the spindle checkpoint at the first meiotic metaphase, and the second at the stage when sperm head elongation and tail development begin. Hopefully, it will not be long before the Y genes matching these two new functions are identified.

Keywords: Mouse; Y chromosome; infertility; spermatogonial proliferation; meiotic checkpoints; spermiogenesis.

Introduction

The first evidence that the mammalian Y chromosome encodes information essential for spermatogenesis that is separable from the testis determinant was published for the human Y chromosome in 1976 (the azoospermia factor, AZF), and evidence for a spermatogenesis gene on the mouse Y chromosome 10 years later (Burgoyne *et al.*, 1986; Levy and Burgoyne, 1986a; Tiepolo and Zuffardi, 1976). In the ensuing years, the study of men and mice with deletions of the Y chromosome has increased the number of separable Y-encoded functions in spermatogenesis, and one or a few candidate Y chromosomal genes have been identified within each of the deletion intervals (Mitchell, 2000; Vogt, 2005). Yet, progress in assigning the spermatogenic functions to specific Y genes has been painfully slow. This reflects the fact that the Y chromosome, aside from the pseudoautosomal region (PAR), is isolated from the reciprocal recombination with a paired homolog during meiosis that has underpinned the fine mapping of functions and positional cloning of genes elsewhere in the genome. Furthermore, despite extensive attempts, there have been no reports of the production of mice with targeted mutations of mouse Y genes, despite an encouraging report 3 years ago (Rohozinski *et al.*, 2002). Here, we review attempts to match mouse Y genes to their spermatogenic functions by identifying candidate genes in defined deletion intervals, and then adding back the candidate genes singly to see whether they correct the deletion phenotype.

The Structure and Gene Content of the mouse Y Chromosome

The mouse Y chromosome (Fig. 1A) has been estimated to contain ~78 megabases (Mb) of DNA (Gregory *et al.*, 2002), of which 0.7 Mb lies within the single PAR at the end of the long arm (Burgoyne, 1982; Perry *et al.*,

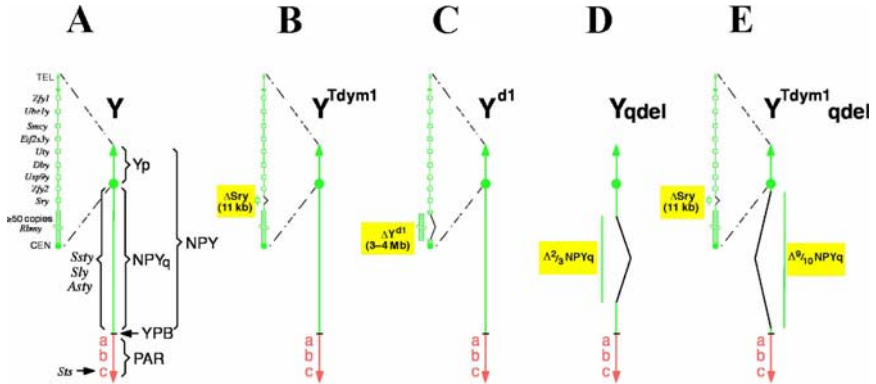

Fig. 1. Diagrammatic representations of the mouse X and Y chromosomes and of variant sex chromosomes relevant to the present review.

A. The mouse Y chromosome comprises a short arm (Yp) with seven mapped single-copy genes including the testis determinant *Sry*, one duplicated gene (*Zfy1/2*), and one multi-copy gene *Rbm10*; a long arm (Yq) that can be divided into the distal pseudoautosomal region (PAR) with a single known gene *Sts*; and the remaining non-PAR (NPYq) that is known to consist of highly repeated DNA including multi-copy genes *Ssty*, *Sly*, and *Asty*. **B.** The Y^{Tdym1} variant has a 11 kb deletion removing the testis determinant *Sry* (Gubbay *et al.*, 1992). **C.** The Y^{d1} variant has a deletion of at least 3–4 Mb that removes the majority of the copies of *Rbm10*. XY^{d1} mice are female because *Sry*, although present, is transcriptionally repressed (Capel *et al.*, 1993). To study spermatogenesis in mice with this deletion, it was necessary to complement the *Sry* deficiency with an *Sry* transgene (Mahadevaiah *et al.*, 1998). **D.** Two *Yqdel* deletions have been described that remove $\sim 2/3$ of NPYq (Conway *et al.*, 1994; Styra *et al.*, 1991a). **E.** A larger deletion of $\sim 9/10$ of NPYq occurs in the context of a Y^{Tdym1} chromosome (Touré *et al.*, 2004c). **F.** The mouse X is acrocentric with a distal PAR. **G.** The Y^*X chromosome is one of two recombinant chromosomes produced by XY^* males (Eicher *et al.*, 1991) (see **J**). It is in essence an X chromosome with a huge deletion removing most of NPX (Burgoyne *et al.*, 1998). **H.** The *Sxr^a* factor, officially denoted $Tp(Y)1Ct^{Sxr-a}$ (Cattanach *et al.*, 1971), comprises most of Yp attached distal to the PAR, where it can cross over and thus be present on the X chromosome as shown or on the Y chromosome. In 1984, the *Sxr^b* variant was discovered, which proved to have >900 kb removing six single-copy Y genes and creating a *Zfy1/2* fusion gene from the two copies of *Zfy* (Mazeyrat *et al.*, 1998; McLaren *et al.*, 1984; Simpson and Page, 1991). **I.** The X^Y chromosome is the second recombinant chromosome generated by XY^* males, and consists of an X chromosome and a Y chromosome joined end to end via their PARs with deletion of both copies of *Sts* (Burgoyne *et al.*, 1998).

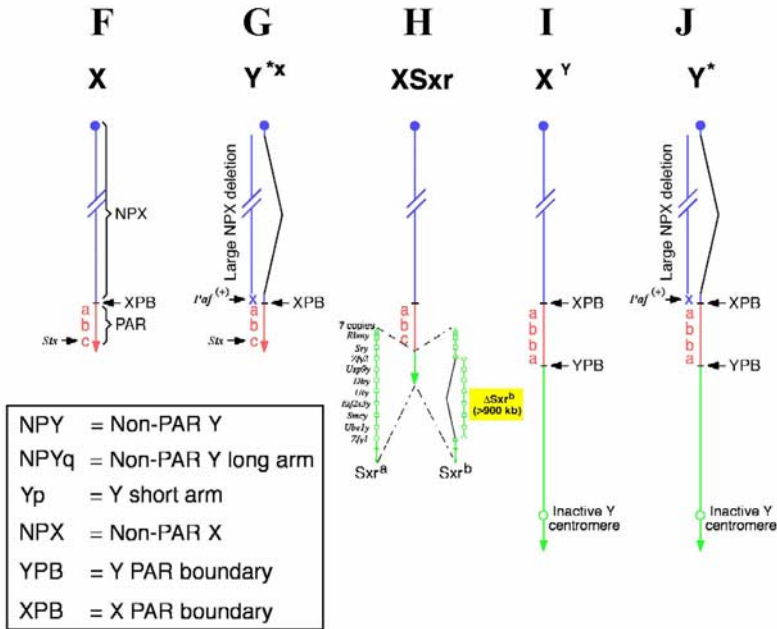

Fig. 1. (Continued)

2001); the PAR is homologous to and recombines with the X PAR. The functional genes so far reported to be present on the mouse Y short arm (Yp) are relatively long-term “residents” on the Y of eutherian mammals, and all have X homologs. All but *Rbmy* have been shown to be present on the Y chromosome of the pig and/or the cat, which are placed in a separate superordinal clade to mouse and man (Murphy *et al.*, 2001). *Rbmy* is considered to be one of the oldest residents (Lahn and Page, 1999; Sandstedt and Tucker, 2004), and — together with *Sry*, *Ube1y*, and *Smcy* — is present on the metatherian Y chromosome (Agulnik *et al.*, 1999; Delbridge *et al.*, 1997; Foster and Graves, 1994; Mitchell *et al.*, 1992). The human Y is unusual in that it lacks *Ube1y* and *Eif2s3y*, which were lost during the evolution of the primate lineage (Ehrmann *et al.*, 1998; Mitchell *et al.*, 1998), but X copies of these genes have of course been retained.

The male-specific region of the mouse Y long arm (non-PAR Y long arm, NPYq), which represents about 90% of the total NPY, contains highly repetitive DNA within which lie multiple copies of at least four distinct

genes that are expressed in spermatids (Bishop and Hatat, 1987; Conway *et al.*, 1994; Prado *et al.*, 1992; Touré *et al.*, 2004a; Touré *et al.*, 2005). These NPYq genes may be restricted to the muridae, since no related Y chromosomal sequences have been detected in the rat by Southern analysis.

The Y^{d1} Deletion Causes an Increase in Sperm Defects and *Rbmy* Deficiency

As will become apparent in the course of this review, the mouse Yp-derived sex reversal factor *Sxr^a* (Fig. 1H) — officially denoted Tp(Y)1Ct^{*Sxr-a*} (Cattanach *et al.*, 1971) — has been of critical importance in delineating mouse Y functions in spermatogenesis. Carrier males have an additional copy of most of Yp (from the telomere to within the *Rbmy* cluster close to the centromere) located on Yq distal to the PAR, and this can consequently be transferred to the X chromosome by PAR recombination. *Sxr^a* can also recombine with Yp (McLaren *et al.*, 1988); this, by unequal crossing-over within the *Rbmy* repeat, very occasionally deletes multiple copies of the repeat (Laval *et al.*, 1995). The Y^{d1} deletion (Δ^{d1}) is the most extensive (at least 3–4Mb), with a >10-fold reduction in *Rbmy* copies (Fig. 1C) and an even greater reduction in *Rbmy* transcription (Mahadevaiah *et al.*, 1998). Males with this deletion have an increased incidence of sperm with sperm head defects (Fig. 2). *Rbmy* encodes a nuclear RNA-binding protein that is implicated in splicing (Elliott, 2000; Elliott *et al.*, 1996). From their expression analysis, Mahadevaiah *et al.* (1998) concluded that *Rbmy* is expressed in spermatogonia, is shut down in pachytene spermatocytes (in which the X and Y chromosomes are transcriptionally repressed — see chapter 2), and is then reactivated in spermatids with the remaining protein expressed in elongating spermatid stages. This pattern of expression suggested that reduced expression of *Rbmy* in Δ^{d1} males during spermiogenesis might be responsible for the increased incidence of abnormal sperm heads. However, the Δ^{d1} sperm phenotype was not “rescued” by the provision of an *Rbmy* transgene comprising an *Rbmy* cDNA driven by the spermatid-specific mouse protamine 1 (mP1) promoter, even though transcription and translation of *Rbmy* from the transgene was confirmed (Szot *et al.*, 2003).

Perplexingly, the antibody used in this study failed to detect any RBMY protein in spermatids in the control males; this is in agreement with the

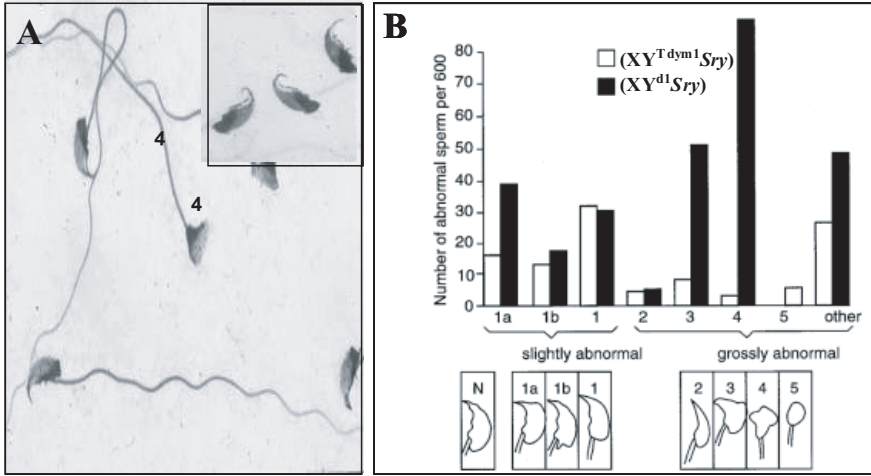

Fig. 2. The Y^{dl} deletion is associated with an increased frequency of abnormal sperm, although males with this deletion are fertile. **A.** Sperm from an $XY^{dl}Sry$ male, showing two normal sperm and two sperm with the most prevalent head abnormality (4) (cf. sperm from control $XY^{Tdym1}Sry$ male, inset). **B.** Histogram showing the overall increase in frequency of abnormal sperm in $XY^{dl}Sry$ males as compared to controls (data from Mahadevaiah *et al.*, 1998).

recent findings by another group (Lee *et al.*, 2004), who failed to detect either *Rbmy* RNA (by *in situ* hybridization) or RBMY protein in spermatids. Nevertheless, we feel it is premature to conclude that the original evidence of expression in spermatids is incorrect. There is no question, in our view, that the *Rbmy* cDNA probe used by Mahadevaiah *et al.* (1998) detected transcripts in round spermatids, so it is not clear why the *Rbmy* cDNA used by Lee *et al.* (2004) to provide a probe for *in situ* hybridization failed to show specific localization to round spermatids. With respect to the conflicting antibody results, it remains possible that spermatids transcribe an *Rbmy* splice variant encoding a protein that lacks the epitope recognized by the later antibodies. The *Rbmy* cDNA used for the mP1-*Rbmy* transgene construct that did produce a protein detected by our later antibody originated from a 17.5 dpp testis library, and was thus not derived from a spermatid transcript.

If *Rbmy* is not expressed in spermatids, it seems perhaps unlikely that the reduced expression in spermatogonia and early spermatocytes in Δ^{dl} males would lead to an increased incidence of sperm head abnormalities. It is of

course possible that there is another gene(s) mapping to this deletion interval that is expressed in spermatids, but no other genes have yet been identified in this interval. Another possibility is that the deletion leads to the repression of a gene lying outside the deletion. We already know that Δ^{d1} leads to the repression of *Sry* transcription; indeed, Δ^{d1} mice develop as females (Capel *et al.*, 1993), and the identification of the effects of the deletion on spermatogenesis required the addition of an *Sry* transgene (Mahadevaiah *et al.*, 1998). The repression of *Sry* is thought likely to be due to the gene having been brought close to centromeric heterochromatin. Very recently, a Y-encoded transcript was identified that almost certainly derives from spermatids (Ellis *et al.*, 2005) and that matched a Y transcript (XM_358268) predicted from the mouse Y sequence; the gene(s) encoding this sequence apparently maps somewhere between *Zfy2* and the Yd1 deletion. However, by microarray testis transcriptome analysis of Δ^{d1} males, we have been unable to detect a reduction of XM_358268 or any other Y-encoded transcript that would constitute alternative candidates to *Rbmy*.

NPYq Deletions Affect Sperm Development, with Larger Deletions Causing Sterility

Two deletions removing $\sim 2/3$ of NPYq ($\Delta^{2/3}$ NPYq) have been described: one involving a C57BL/10 strain Y chromosome, and the other an RIII strain Y chromosome (Fig. 1D). Both deletions have been shown to cause minor changes in sperm head shape, notably a flattening of the acrosomal cap (Fig. 3B); and although the mice are of good fertility, *in vitro* tests showed that the sperm have impaired fertilizing ability and that there is an intriguing distortion of the offspring sex ratio in favor of females (Conway *et al.*, 1994; Moriwaki *et al.*, 1988; Siruntawineti *et al.*, 2002; Styrna *et al.*, 2002; Styrna *et al.*, 1991a; Styrna *et al.*, 2003; Styrna *et al.*, 1991b; Touré *et al.*, 2004b; Xian *et al.*, 1992). Analysis of mice with the B10 Y deletion also found increased aromatase activity in the testis with a consequent increase in levels of estradiol relative to testosterone (Kotula-Balak *et al.*, 2004).

Two, more extensive, NPYq deficiencies have been described that cause sterility. Total absence of NPYq (NPYq⁻) occurs in mice with the exotic genotype $XSxr^aY^{*X}$ (Burgoyne *et al.*, 1992), in which the only NPY region present is the Yp-derived *Sxr^a* (Fig. 1H). The minute Y^{*X} chromosome

(Eicher *et al.*, 1991) is in effect a highly deleted X chromosome (Burgoyne and Evans, 2000; Burgoyne *et al.*, 1998), and serves to provide a second PAR (Fig. 1G). The second is a recently described deletion removing $\sim 9/10$ of NPYq ($\Delta^{9/10}$ NPYq) that occurs in the context of an *Sry*-negative Y chromosome (Fig. 1E), necessitating the complementation of the *Sry* deficiency with an *Sry* transgene (Touré *et al.*, 2004b). In both cases, all the sperm have grossly misshapen sperm heads (Figs. 3C and 3D), which are presumably the cause of the infertility.

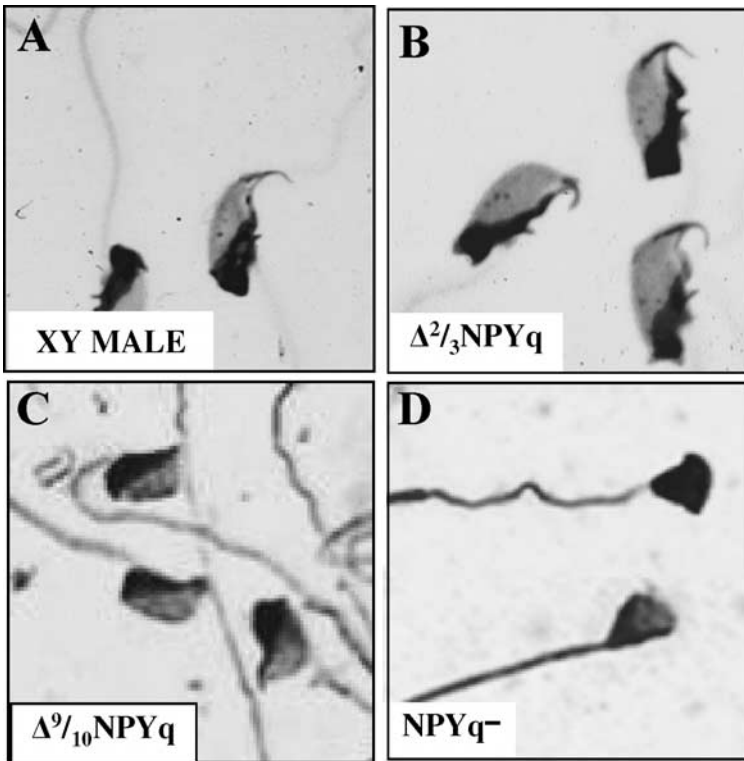

Fig. 3. Sperm abnormalities in mice with NPYq deficiencies. A. Sperm from a control male. B. Sperm from a $\Delta^{2/3}$ NPYq male, in which the majority of sperm have a broadening of the acrosomal region and a flattening of the acrosome anteriorly. Although the sperm perform poorly *in vitro*, the males are fertile. C. Sperm from a $\Delta^{9/10}$ NPYq male showing the more severely affected sperm, again with a flattened acrosome anteriorly. These males are almost invariably sterile. D. Grossly abnormal sperm from an $XSx^{d}Y^{*X}$ (NPYq⁻) male, in which the Yp-derived *Sxr^d* factor provides the only NPY material. All males tested are sterile.

In considering what might be the genetic basis of the spermiogenic defects in mice with NPYq deficiencies, it is simpler to summarize what we now know about the NPYq-encoded testis transcriptome rather than to give a historical perspective. We sought to determine this directly by generating a mouse testis cDNA microarray enriched for spermatogenic cell transcripts (Ellis *et al.*, 2004), and then identifying NPYq-encoded transcripts among those that are dramatically reduced or absent in $\Delta^9/10$ NPYq and NPYq⁻ males (Touré *et al.*, 2005). This study was complemented by the Mouse Y Sequencing Program, which has been tackling the herculean task of sequencing NPYq [Mouse Chromosome Y Mapping Project (Jessica E. Alfoldi, Helen Skaletsky, Steve Rozen, and David C. Page at the Whitehead Institute for Biomedical Research, Cambridge, MA, and the Washington University Genome Sequencing Center, St. Louis, MO)]. The testis-expressed NPYq genes identified so far (*Ssty1/2*, *Sly*, and *Asty*) are multi-copy, are expressed in spermatids, and show a progressive reduction in transcript levels with increasing NPYq deficiency; thus, they are all candidates for contributing to the sperm defects associated with NPYq deletions. All have multi-copy X homologs.

Based on the microarray data and Northern analysis, *Ssty2* appears to be the most abundant transcript, but no protein product has yet been identified. *Ssty1* is much less abundant, but does produce a protein (Touré *et al.*, 2004a) that has substantial homology to the autosomally encoded protein SPIN (Oh *et al.*, 1998; Oh *et al.*, 1997). Genes encoding SPIN are now widely found in vertebrates including man, chicken, the frog *Xenopus tropicalis*, and fish (Itoh *et al.*, 2001; Wang *et al.*, 2005). In the mouse, SPIN is found in oocytes and early embryos, where it locates to the metaphase spindle (Oh *et al.*, 1998). *Sly* is also a very abundant transcript in spermatids, but it is not yet known whether the transcripts are translated. If *Sly* does make a protein, it would have substantial homology to the chromatin-associated proteins XLR (46% amino acid identity) and XMR (48% identity) that are encoded by the related multi-copy *Xlr/Xmr* gene family on the X chromosome. These related X and Y genes in turn have homology — particularly in the COR 1 domain (pFAM accession PF04803) — with the protein SYCP3, which is also chromatin-associated in that it is a component of the synaptonemal complex of paired homologous chromosomes in meiosis. *Asty* seems to be transcribed at a very low level, but there are transcripts derived from *Asty*

recombinant loci [*Asty(rec)*] lacking the first *Asty* exon and driven by an *Ssty1* promoter that seem to be more abundant. At present, no strong case can be made for the translation of the *Asty* or *Asty/rec* transcripts.

On and off over the past 12 years, we have attempted transgene rescue of the MSYq deletion phenotypes. Initially, we used *Ssty1* and *Ssty2* cDNAs driven by the spermatid-specific mP1 promoter (which was used for the *Rbmy* cDNA transgene construct). These *Ssty1* and *Ssty2* transgenes were expressed at levels close to endogenous levels, but neither singly nor in combination had any detectable effect on the flattened acrosome phenotype or offspring sex ratio distortion of $\Delta^{2/3}$ NPYq males, or on the more severe sperm defects of $\Delta^9/_{10}$ NPYq and NPYq⁻ males (unpublished data). However, we subsequently found that the mP1-*Ssty1* transgene is not translated (supplemental information in Touré *et al.*, 2004a). Since then, we have made transgenic lines with partially characterized genomic BAC clones containing *Ssty1* and/or *Ssty2*, but these failed to transcribe. Most recently, we have tried a sequenced *Sly* BAC (kindly provided by Jessica Alfoldi of the Mouse Y Sequencing Consortium), but again this failed to rescue the MSYq-deletion phenotypes. However, the level of expression from the *Sly* transgene was markedly lower than the endogenous level, so this needs to be repeated with a more highly expressing *Sly* transgene. An alternative approach for these multi-copy NPYq genes would be to reduce transcript levels in normal males for each gene separately by using an RNAi approach, either by injecting the siRNAs directly into the testis (Shoji *et al.*, 2005) or by transgenic delivery of short hairpin RNAs that are converted into siRNAs (Rubinson *et al.*, 2003).

Evidence That an NPYq Gene(s) Represses X Gene Expression in Spermatids

The microarray analysis of the testis transcriptome of the males with NPYq deficiencies, in addition to identifying NPYq genes expressed in the testis, also identified some downstream transcriptional consequences of the deficiencies. The most dramatic finding was that a number of X-linked genes expressed in spermatids were markedly upregulated, among which were *Xmr* and some *Xmr*-related family members. As we have seen, *Xmr* shows significant homology to the NPYq multi-copy gene *Sly* and is a member of the complex X-linked *Xmr/Xlr* gene family of chromatin-associated

proteins. It has previously been argued that the amplification of X and Y genes could be a consequence of a past “genomic conflict” between sex-linked meiotic drivers and suppressors (Hurst, 1992). Briefly, if the X acquires a gene (or a mutation) that promotes transmission of X-bearing gametes, thus distorting the sex ratio in favor of females, then there will be selection for a mechanism that will counteract this sex ratio distortion; this could be the acquisition or mutation of a Y gene that acts to rebalance the sex ratio. Duplication of the X gene may then distort the sex ratio again, leading to selection for duplication of the Y gene; over time, this may lead to multiple copies of the X and Y genes, which are in balance with respect to their effects on the sex ratio. Deletion of some of the Y genes is predicted to lead to offspring sex ratio distortion in favor of females, just as we see with $\Delta^2/3$ NPYq. Support for this genomic conflict model is provided by *Drosophila Stellate* (multi-copy gene on the X encoding a subunit of casein kinase II) and *Suppressor of Stellate* (multi-copy suppressor on the Y) (Hurst, 1992; Hurst, 1996). Recent evidence suggests that *Suppressor of Stellate* keeps *Stellate* in check by generating small interfering RNAs that target the *Stellate* RNA (Aravin *et al.*, 2001). We feel that the situation in the mouse is likely to be more complicated because not only are several X genes upregulated in spermatids, but so are some spermatid-expressed Yp genes (Ellis *et al.*, 2005). Solving this puzzle will be a fascinating task for the future.

The Consequences of Sex Chromosome Univalence at the First Meiotic Metaphase

Evidence from yeast to man has established that when mitotic cells reach metaphase of the cell division cycle, the cell checks to make sure that all the chromosomes have a bipolar attachment of their centromeres (kinetochores) to the mitotic spindle, and that anaphase onset (chromatid separation) is prevented if this is not achieved (Tan *et al.*, 2005). It is widely assumed that a similar checkpoint operates at the first and second meiotic metaphases. The mechanics of the second meiotic division are exactly comparable to mitosis, but the first meiotic metaphase (MI) is unusual in that it is the pairs of homologous chromosomes (each pair is termed a bivalent) that must align on the metaphase plate and separate into their constituent chromosomes at

anaphase. This requires that the two kinetochores (of the two chromatids) of one chromosome must mono-orient towards one spindle pole, and the two kinetochores of the second chromosome must mono-orient towards the opposite spindle pole; following attachment to the spindle, the two chromosomes are then drawn to opposite poles. While the molecular basis of the spindle checkpoint at the first meiotic metaphase has been defined in some detail in the yeast and is closely related to that operating at mitosis, the details are less clear for mammals (Petronczki *et al.*, 2003). Furthermore, there seem to be differences in the efficiency of the spindle checkpoint between male and female mammals (Eaker *et al.*, 2002; Eaker *et al.*, 2001; Homer *et al.*, 2005; LeMaire-Adkins *et al.*, 1997; Wassmann *et al.*, 2003).

For the XY pair in mouse spermatogenesis, it is the obligate chiasma between the X and Y PARs that holds the X-Y bivalent together at the first meiotic metaphase, and it is the pairs of X and Y kinetochores that orient towards opposite poles; thus, the X and Y separate at anaphase I (Fig. 4A). In the $XSxr^aY^{*X}$ (NPYq⁻) mouse described in the previous section, the obligate chiasma is in fact between two X PARs and it is two X centromeres that attach to opposite spindle poles. Nevertheless, this minimal sex bivalent satisfies the requirements of the spindle checkpoint and, as described in the previous section, these mice have active spermiogenesis (although the sperm produced are grossly abnormal). The crucial importance of maintaining a sex bivalent association by means of this PAR-located chiasma can be illustrated by considering the consequences of removing the Y^{*X} chromosome to produce an $XSxr^aO$ male. With only a single univalent sex chromosome present, spermatogenesis arrests at MI and the arrested cells are eliminated by apoptosis (Cattanach *et al.*, 1971; Kot and Handel, 1990; Sutcliffe *et al.*, 1991). The same MI arrest is seen in males with a single X-attached-Y chromosome (X^Y , Fig. 1I), but importantly, in this case the addition of a Y^{*X} chromosome (to give $X^Y Y^{*X}$) does not overcome the arrest (Burgoyne *et al.*, 1992). The crucial difference between the two genotypes is that $XSxr^a Y^{*X}$ males form a sex bivalent; but in $X^Y Y^{*X}$ males, the interstitial positioning of the X^Y PAR is incompatible with synapsis, and thus the X^Y and Y^{*X} are present as univalents at MI. Although in 1992 we favored the view that the MI arrest reflected a requirement for PAR synapsis *per se*, we now believe the MI arrest and subsequent apoptosis are due to the operation of an MI checkpoint which, as in yeast, detects the presence of univalent chromosomes that are only attached to a single spindle pole

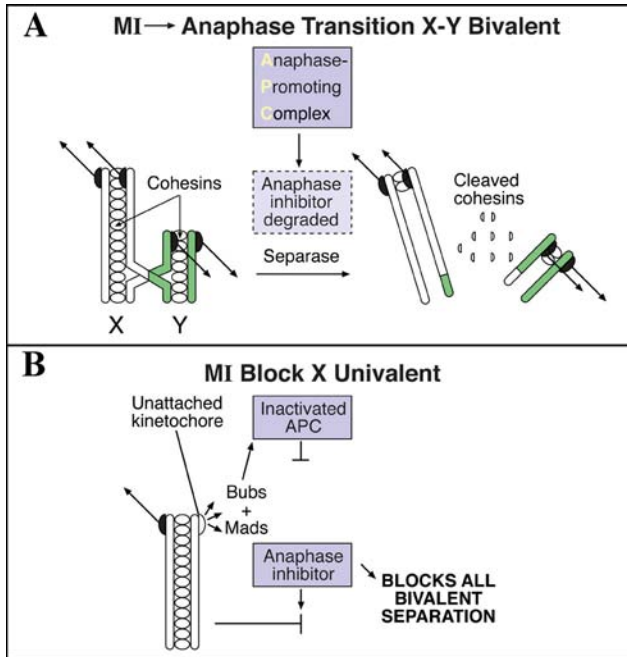

Fig. 4. The disjunction of the X and Y at the first meiotic division, and the postulated spindle checkpoint response in the face of sex chromosome univalence. A. All the paired chromosomes (bivalents) have to align on the metaphase plate before disjunction of homologs takes place. In the case of the X-Y bivalent, this requires that the two kinetochores of the sister X chromatids mono-orient towards one pole and attach to spindle microtubules originating from that pole (syntelic attachment), while the sister Y chromatids achieve syntelic attachment to the opposite pole. Once all bivalents are attached in this way to the spindle, the anaphase-promoting complex (APC) triggers the degradation of an inhibitor of the enzyme separase, which then cleaves the cohesins between the chromatid arms (but not at the centromeres) of all the bivalents. This releases the link between homologs provided by chiasmata (the obligatory PAR chiasma in the case of the X-Y bivalent), allowing homologs to disjoin (Petronczki *et al.*, 2003). **B.** If any univalent chromosomes are present (for example, the X of *X.Sxr^dO* males), this is thought to inhibit mono-orientation, and either attachment to the spindle fails to take place or (as illustrated) a single kinetochore attachment is made; bipolar attachment is rarely achieved. If kinetochores that are not attached to the spindle are present, spindle checkpoint proteins of the Bub and Mad families maintain the APC in an inactive state and the anaphase inhibitor prevents activation of separase, thus preventing disjunction of all bivalents. In the rare case when bipolar attachment to the spindle is achieved, this may avoid the spindle checkpoint and lead to separation of the chromatids of the univalent at MI. This model is based principally on molecular analysis of the checkpoint in budding yeast, but the molecular details of the checkpoint at MI in male mammals is ill-defined. Indeed, one of the spindle checkpoint proteins, Mad2, which is shed from the kinetochores during mitosis when spindle attachments are completed, is apparently retained at the kinetochores throughout the first meiotic division in male rats and mice (Kallio *et al.*, 2000).

(Fig. 4B). The important message in the current context is that sex chromosome univalence will cause MI arrest, even if there is a full complement of Y genes.

***Eif2s3y* from the *Sxr^b* Interval on Yp Has a Role in Spermatogonial Proliferation**

An important milestone in defining the functions of the mouse Y chromosome was the discovery by McLaren *et al.* (1984) of the variant *Sxr^b* (Fig. 1H), officially Tp(Y)1Ct^{*Sxr^b*}, which had lost genetic information required for H-Y antigen expression. Subsequent comparison of X*Sxr^b*O with X*Sxr^a*O males revealed that this variant had also lost information needed for normal spermatogonial proliferation (Burgoyne *et al.*, 1986; Sutcliffe and Burgoyne, 1989). The *Sxr^b* variant arose in a male that was carrying two copies of *Sxr^a*, one attached to the X PAR and the other to the Y PAR, and it was suspected that unequal crossing-over had resulted in the deletion of a gene(s) encoding H-Y. This was subsequently substantiated by Simpson and Page (1991), who showed that there was indeed a deletion with breakpoints lying within the zinc finger genes *Zfy1* and *Zfy2*. It was concluded that *Zfy1* from one *Sxr^a* copy had aligned and recombined with *Zfy2* from the second *Sxr^a* copy, and the result was the generation of a *Zfy2/Zfy1* fusion gene (which is still transcribed) and the loss of the >900 kb of DNA lying between the two loci. The first gene to be identified from within the deletion was *Ubely*, which — like its X homolog *Ubelx* — is presumed to produce the ubiquitinating enzyme E1 (Kay *et al.*, 1991; Mitchell *et al.*, 1991), but it was a further 7 years before the full (we hope!) gene content of the deletion interval was determined (Mazeyrat *et al.*, 1998).

Attempts to rescue the spermatogonial block in X*Sxr^b*O mice by adding back genes from the *Sxr^b* deletion interval, as transgenes followed along in the wake of the gene discovery (Agulnik *et al.*, 2001; Mazeyrat *et al.*, 2001), eventually established that the spermatogonial proliferation factor was *Eif2s3y* (Mazeyrat *et al.*, 2001). *Eif2s3y* is a Y chromosomal homolog of the X-linked *Eif2s3x* that encodes subunit 3 of the translation elongation and initiation factor EIF2. Since making proteins is an essential cellular function, it is not surprising that these genes are widely (presumably ubiquitously) expressed (Ehrmann *et al.*, 1998). However, given the near

identity (97%) of the predicted X- and Y-encoded proteins, why has a functional copy been retained on the majority of eutherian Y chromosomes? *Eif2s3x* is one of only a handful of mouse X genes that are known to escape X inactivation (Ehrmann *et al.*, 1998) and that have ubiquitously expressed Y homologs. It is argued that these genes encode functions for which expressed dosage is critical; and that this has required the retention of functional Y copies, together with X copies, which escape X inactivation. We have formally tested the underlying assumption that the *Eif2s3y* and *Eif2s3x* serve equivalent functions by seeing if an *Eif2s3x* transgene also rescued the spermatogonial block in $XSxr^bO$ males; this proved to be the case (unpublished). This still begs the question as to why differentiating A spermatogonia are the only cells for which EIF2S3 dosage is critical. As we observed earlier, the human Y does not have a copy of *Eif2s3y*, but it does have an autosomal copy originating from retroposition of an X transcript, which may have allowed the loss of the Y copy (Ehrmann *et al.*, 1998).

Are there any genes remaining in Sxr^b that are essential for spermatogenesis prior to the block seen in $XSxr^bO$ males? Sxr^b includes the testis determinant *Sry*, which is required for obvious reasons. But, evidence that there are no other mouse Y genes with essential early spermatogenic functions comes from our finding that XO,Sry transgenic males have a block in spermatogonial proliferation indistinguishable from that in $XSxr^bO$ mice, and that addition of *Eif2s3y* to XO,Sry transgenic males similarly overcomes this block (Mazeyrat *et al.*, 2001).

Evidence for Further Spermatogenic Functions on Yp Mapping to ΔSxr^b

It is our belief that the majority of the current mouse Yp gene complements, particularly those that have a testis-specific pattern of expression (e.g. *Zfy1/2*, *Ube1y*, *Usp9y*), will prove to potentiate the spermatogenic process, even if they are not essential. We have therefore analyzed the spermatogenic phenotype of the $XSxr^bO$ males and $XO,Sry Eif2s3y$ transgene rescue males (hereafter referred to as “*Eif2* rescue males”), seeking to obtain evidence for functions that can be linked by transgene rescue to further ΔSxr^b genes. If the addition of *Eif2s3y* achieved full rescue of the ΔSxr^b phenotype, the mice would be expected to show the checkpoint-initiated MI arrest and apoptosis that are seen in $XSxr^aO$ males. If so, then provision of the Y^{*X} to

generate a minimal sex bivalent, and thus avoid the MI checkpoint, should allow assessment of any postmeiotic functions of ΔSxr^b .

As already pointed out by Mazeyrat *et al.* (2001), the spermatogenic phenotype of the *Eif2* rescue males is not equivalent to that seen in $XSxr^a$ O males. Intriguingly, spermatogenesis proceeds a little further, with the majority of spermatocytes completing the first meiotic division to form diploid secondary spermatocytes, but failing to undergo the second meiotic division (Fig. 6A). This spermatogenic phenotype suggests two possible ΔSxr^b gene functions: one needed for the efficient functioning of the MI spindle checkpoint, and one to allow progression through the second meiotic division. We have so far added back to the *Eif2* rescue males the ΔSxr^b genes *Ubel1y*, *Dby*, *Smcy*, and *Usp9y*; individually, none of these transgenes have reinstated the MI checkpoint. The only other candidate gene we know of within the interval is *Uty*, for which we now have transgenic lines established. However, it also remains possible that the disruption of the MI checkpoint is a consequence of *Zfy* deficiency, since only a single *Zfy2/1* fusion gene remains in the deletion mice. Alternatively, it could be that the simultaneous reintroduction of two ΔSxr^b genes is required to reinstate MI checkpoint function.

Although we have as yet been unable to reinstate the MI checkpoint function, we have nevertheless gone ahead and added back Y^{*X} to *Eif2* rescue males in order to recreate a minimal sex bivalent and thus avoid any checkpoint response to sex chromosome univalence. If the failure to progress through the second meiotic division is due to a ΔSxr^b gene deficiency, the addition of Y^{*X} should make no difference, but in fact we found that the majority of secondary spermatocytes now complete the second division to form haploid round spermatids (Fig. 5A). This implies that the failure to complete the second meiotic division is a consequence of sex chromosome univalence (or PAR dosage deficiency) rather than the lack of a ΔSxr^b gene.

In the absence of any further ΔSxr^b gene functions, we would expect the spermatogenic phenotype of the *Eif2* rescue males after the addition of Y^{*X} to equate to that in $XSxr^a Y^{*X}$ males; namely, active spermiogenesis with the production of near normal numbers of sperm, albeit with grossly abnormal heads (Burgoyne *et al.*, 1992). However, the haploid spermatids formed in these *Eif2* rescue + Y^{*X} males fail to elongate or form an axoneme (Fig. 5B), thus encouraging our view that there will be further identifiable

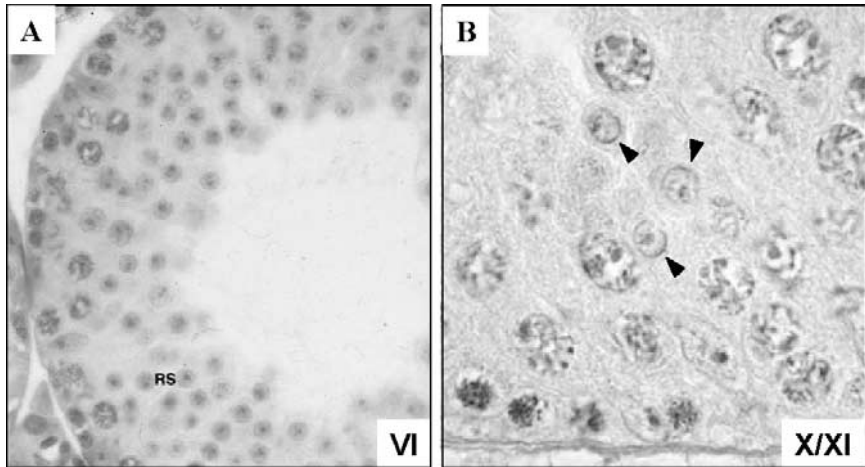

Fig. 5. A gene mapping to the ΔSxr^b interval on mouse Yp has a role in spermatid development. $XSxr^bO, Eif2s3y$ males, in which the spermatogonial block due to ΔSxr^b has been rescued by an $Eif2s3y$ transgene, have spermatogenic arrest during the meiotic divisions (see Fig. 6A) (Mazeyrat *et al.*, 2001). This arrest can be avoided by providing the tiny Y^{*X} chromosome (Fig. 1G) which, through PAR recombination with the $XSxr^b$ chromosome, forms a sex bivalent. **A.** At tubule stage VI in these $XSxr^bY^{*X}, Eif2s3y$ males, it is apparent that spermatogenesis has progressed to the round spermatid stage (RS). **B.** At tubule stage X/XI, spermatids of control males or $XSxr^bY^{*X}$ males have elongated heads with a developing axoneme (not shown); but in these $XSxr^bY^{*X}, Eif2s3y$ males, the sperm head fails to elongate and there is no axoneme (step 7 arrest — arrows).

functions for ΔSxr^b genes. Once again, we have tried transgene rescue to overcome the block in spermatid differentiation; frustratingly, *Ube1y*, *Dby*, *Smcy*, and *Usp9y* have each again failed to rescue the block. *Usp9y* was our strong favorite, but because this is a very large gene with 47 exons spanning ~ 80 kb, we had to create a minigene for the transgene rescue. We know the minigene is transcribing appropriately in spermatids, but we have yet to show that the transgene RNA is translated.

Secondary Changes in the Testicular Phenotype in Mice with Y Deficiencies

Because the mice with Y deficiencies that we have studied can be generated at will (although often requiring complex mouse crosses), we have the luxury of being able to study the spermatogenic phenotype from birth

through to adulthood. Such longitudinal studies have previously suggested that genetic defects which initially lead to arrest at specific spermatogenic stages may subsequently manifest with a more complex phenotype as a consequence of secondary changes. Thus, in *X^{Sxr^b}O* males, studies of the first spermatogenic wave revealed a uniform block in the proliferation of differentiating A spermatogonia; but very occasionally, groups of cells that reached the pachytene stage were seen in older mice (Burgoyne *et al.*, 1986; Sutcliffe and Burgoyne, 1989). Similarly, in young *X^{Sxr^a}O* males, there is almost total arrest at MI followed by apoptotic elimination of all the arrested cells; but in older males, some cells complete one or both meiotic divisions and may progress through spermiogenesis to form sperm with abnormal sperm heads (Levy and Burgoyne, 1986b; Sutcliffe *et al.*, 1991).

We have documented the secondary changes a little more thoroughly in *Eif2* rescue males (Mazeyrat *et al.*, 2001). In the mouse, the first wave of spermatogenesis is complete by about 1 month. At this age, the *Eif2* rescue males show a uniform phenotype of spermatocyte arrest prior to the second meiotic metaphase, with the arrested cells remaining for one or more spermatogenic cycles before forming multinucleate bodies (apoptotic?) that are presumably in the process of being phagocytosed by the Sertoli cells (Fig. 6B). By 2 months (mice are mature at 6 weeks), holes begin to appear at the base of the seminiferous epithelium, perhaps due to the death of Sertoli cells that have been overwhelmed by the apoptotic load (Fig. 6C). This undoubtedly destroys the patency of the Sertoli cell tight-junctional blood-testis barrier, which separates premeiotic from meiotic cells (Dym and Fawcett, 1970; Xia *et al.*, 2005). By 3 months, there is usually a mosaic phenotype: some tubule sections show severe germ cell loss [and may even appear to be Sertoli cell-only (SCO)]; but paradoxically, some others have elongating spermatids present, albeit with abnormal heads (Fig. 6D). This is very reminiscent of the testicular phenotype of many men with AZFb or AZFc deletions. By 6 months, some *Eif2* rescue males have such severe spermatogenic damage that it would be easy to mistake them for males without the *Eif2s3y* transgene (Fig. 6E).

It is important to note that although in some tubules the spermatogenesis gets progressively worse, in others spermatogenesis may proceed beyond the stage of the initial block for a while. In this context, it is important to remember that all mouse Y genes identified so far have related homologs on

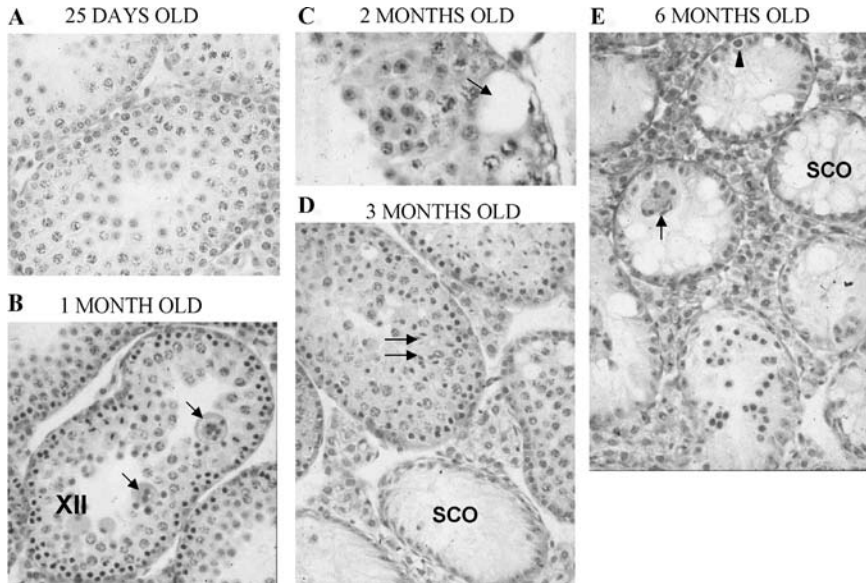

Fig. 6. Secondary changes in the testes of $Xsxr^{b}O, Eif2s3y$ males. **A.** At 25 days, there is a uniform arrest — spermatocytes complete the first meiotic division, but fail to progress through the second meiotic division. **B.** At 1 month, the arrested cells from the previous spermatogenic cycle are seen being removed in stage XII tubules, as evidenced by the formation of multinucleate bodies (arrows). **C.** By 2 months, large vacuoles (arrow) begin to appear that span from the basal lamina to the pachytene spermatocyte layer; this suggests that they may breach the Sertoli cell tight-junctional blood-testis barrier. **D.** At 3 months, a mosaic phenotype begins to appear, with spermatogenesis now progressing to elongating spermatid stages (arrows), while in other tubules there is spermatogenic failure with only Sertoli cells remaining (SCO). **E.** Although the rate at which secondary damage progresses is variable, by 6 months some testes have very little spermatogenic activity remaining. The lower tubule has what appear to be pycnotic spermatocytes; other tubules have only Sertoli cells and spermatogonia (arrowhead) or only Sertoli cells (SCO), while in some the Sertoli cells are beginning to slough off (arrow).

the X chromosome, and in several cases (e.g. *Eif2s3y*) the proteins encoded by the X and Y genes are sufficiently similar to be expected to have near identical properties. We suspect that it is the abrogation of Sertoli responses to arrested cells usually ensuring their prompt removal, together with the accumulation of X-encoded proteins, that may allow progression beyond the initial block. In light of these observations in the mouse, the spermatogenic phenotype in men with Y deletions when they first present at a fertility

clinic may be far removed from that present years earlier, when the Y gene deficiency first impacts on spermatogenesis.

It is a sobering thought for those battling to document mammalian Y gene functions in spermatogenesis that mice spermatogenic cells with only two Y genes, *Sry* and *Eif2s3y*, can in some circumstances complete spermatogenesis and produce sperm, although they do have distorted heads. This supports the view that many Y genes have been retained on the Y because they potentiate the spermatogenic process rather than because they provide an essential spermatogenic function (Burgoyne, 1998). However, despite the delaying tactics afforded by gene conversion in palindromic Y chromosomal repeats (Rozen *et al.*, 2003), the mammalian Y is probably on an evolutionary road to oblivion (Graves, 2004); in at least one mammal, the creeping vole *Ellobius lutescens*, the Y has already reached the end of the road (Just *et al.*, 1995).

Acknowledgments

We thank Dirk de Rooij for providing Fig. 5B.

References

- Agulnik, A. I., Harrison, W. R., and Bishop, C. E. (2001). *Smcy* transgene does not rescue spermatogenesis in sex-reversed mice. *Mamm Genome* **12**, 112–116.
- Agulnik, A. I., Longepied, G., Ty, M. T., Bishop, C. E., and Mitchell, M. (1999). Mouse H-Y encoding *Smcy* gene and its X chromosomal homologue *Smcx*. *Mamm Genome* **10**, 926–929.
- Aravin, A. A., Naumova, N. M., Tulin, A. V., Vagin, V. V., Rozovsky, Y. M., and Gvozdev, V. A. (2001). Double-stranded RNA-mediated silencing of genomic tandem repeats and transposable elements in the *D. melanogaster* germline. *Curr Biol* **11**, 1017–1027.
- Bishop, C. E., and Hatat, D. (1987). Molecular cloning and sequence analysis of a mouse Y chromosome RNA transcript expressed in the testis. *Nucleic Acids Res* **15**, 2959–2969.
- Burgoyne, P. S. (1982). Genetic homology and crossing over in the X and Y chromosomes of mammals. *Hum Genet* **61**, 85–90.
- Burgoyne, P. S. (1998). The mammalian Y chromosome: a new perspective. *Bioessays* **20**, 363–366.
- Burgoyne, P. S., and Evans, E. P. (2000). A high frequency of XO offspring from *XPafY** male mice: evidence that the *Paf* mutation involves an inversion spanning the X PAR boundary. *Cytogenet Cell Genet* **91**, 57–61.
- Burgoyne, P. S., Levy, E. R., and McLaren, A. (1986). Spermatogenic failure in male mice lacking H-Y antigen. *Nature* **320**, 170–172.

- Burgoyne, P. S., Mahadevaiah, S. K., Perry, J., Palmer, S. J., and Ashworth, A. (1998). The Y* rearrangement in mice: new insights into a perplexing PAR. *Cytogenet Cell Genet* **80**, 37–40.
- Burgoyne, P. S., Mahadevaiah, S. K., Sutcliffe, M. J., and Palmer, S. J. (1992). Fertility in mice requires X-Y pairing and a Y-chromosomal 'spermiogenesis' gene mapping to the long arm. *Cell* **71**, 391–398.
- Capel, B., Rasberry, C., Dyson, J., Bishop, C. E., Simpson, E., Vivian, N., Lovell-Badge, R., Rastan, S., and Cattanach, B. M. (1993). Deletion of Y chromosome sequences located outside the testis determining region can cause XY female sex reversal. *Nat Genet* **5**, 301–307.
- Cattanach, B. M., Pollard, C. E., and Hawkes, S. G. (1971). Sex reversed mice: XX and XO males. *Cytogenetics* **10**, 318–337.
- Conway, S. J., Mahadevaiah, S. K., Darling, S. M., Capel, B., Rattigan, Á. M., and Burgoyne, P. S. (1994). Y353/B: a candidate multiple-copy spermiogenesis gene on the mouse Y chromosome. *Mamm Genome* **5**, 203–210.
- Delbridge, M. L., Harry, J. L., Toder, R., O'Neill, R. J. W., Ma, K., Chandley, A. C., and Graves, J. A. M. (1997). A human candidate spermatogenesis gene, *RBMI*, is conserved and amplified on the marsupial Y chromosome. *Nat Genet* **15**, 131–136.
- Dym, M., and Fawcett, D. W. (1970). The blood-testis barrier in the rat and the physiological compartmentation of the seminiferous epithelium. *Biol Reprod* **3**, 308–326.
- Eaker, S., Cobb, J., Pyle, A., and Handel, M. A. (2002). Meiotic prophase abnormalities and metaphase cell death in MLH1-deficient mouse spermatocytes: insights into regulation of spermatogenic progress. *Dev Biol* **249**, 85–95.
- Eaker, S., Pyle, A., Cobb, J., and Handel, M. A. (2001). Evidence for meiotic spindle checkpoint from analysis of spermatocytes from Robertsonian-chromosome heterozygous mice. *J Cell Sci* **114**, 2953–2965.
- Ehrmann, I. E., Ellis, P. S., Mazeyrat, S., Duthie, S., Brockdorff, N., Mattei, M. G., Gavin, M. A., Affara, N. A., Brown, G. M., Simpson, E., *et al.* (1998). Characterization of genes encoding translation initiation factor eIF-2gamma in mouse and human: sex chromosome localization, escape from X-inactivation and evolution. *Hum Mol Genet* **7**, 1725–1737.
- Eicher, E. M., Hale, D. W., Hunt, P. A., Lee, B. K., Tucker, P. K., King, T. R., Eppig, J. T., and Washburn, L. L. (1991). The mouse Y* chromosome involves a complex rearrangement, including interstitial positioning of the pseudoautosomal region. *Cytogenet Cell Genet* **57**, 221–230.
- Elliott, D. J. (2000). RBMY genes and AZFb deletions. *J Endocrinol Invest* **23**, 652–658.
- Elliott, D. J., Ma, K., Kerr, S. M., Thakrar, R., Speed, R., Chandley, A. C., and Cooke, H. (1996). An *RBM* homologue maps to the mouse Y chromosome and is expressed in germ cells. *Hum Mol Genet* **5**, 869–874.
- Ellis, P. J., Clemente, E. J., Ball, P., Toure, A., Ferguson, L., Turner, J. M., Loveland, K. L., Affara, N. A., and Burgoyne, P. S. (2005). Deletions on mouse Yq lead to upregulation of multiple X- and Y-linked transcripts in spermatids. *Hum Mol Genet* **14**, 2705–2715.
- Ellis, P. J., Furlong, R. A., Wilson, A., Morris, S., Carter, D., Oliver, G., Print, C., Burgoyne, P. S., Loveland, K. L., and Affara, N. A. (2004). Modulation of the mouse testis transcriptome during postnatal development and in selected models of male infertility. *Mol Hum Reprod* **10**, 271–281.

- Foster, J. W., and Graves, J. A. M. (1994). An *SRY*-related sequence on the marsupial X chromosome: implications for the evolution of the mammalian testis-determining gene. *Proc Natl Acad Sci U S A* **91**, 1927–1931.
- Graves, J. A. (2004). The degenerate Y chromosome — can conversion save it? *Reprod Fertil Dev* **16**, 527–534.
- Gregory, S. G., Sekhon, M., Schein, J., Zhao, S., Osoegawa, K., Scott, C. E., Evans, R. S., BurrIDGE, P. W., Cox, T. V., Fox, C. A., *et al.* (2002). A physical map of the mouse genome. *Nature* **418**, 743–750.
- Gubbay, J., Vivian, N., Economou, A., Jackson, D., Goodfellow, P., and Lovell-Badge, R. (1992). Inverted repeat structure of the *Sry* locus in mice. *Proc Natl Acad Sci U S A* **89**, 7953–7957.
- Homer, H. A., McDougall, A., Levasseur, M., and Herbert, M. (2005). Restaging the spindle assembly checkpoint in female mammalian meiosis I. *Cell Cycle* **4**, 650–653.
- Hurst, L. D. (1992). Is *Stellate* a relict meiotic driver? *Genetics* **130**, 229–230.
- Hurst, L. D. (1996). Further evidence consistent with *Stellate*'s involvement in meiotic drive. *Genetics* **142**, 641–643.
- Itoh, Y., Hori, T., Saitoh, H., and Mizuno, S. (2001). Chicken spindlin genes on W and Z chromosomes: transcriptional expression of both genes and dynamic behavior of spindlin in interphase and mitotic cells. *Chromosome Res* **9**, 283–299.
- Just, W., Rau, W., Vogel, W., Akhverdian, M., Fredga, K., Graves, J. A. M., and Lyapunova, E. (1995). Absence of *Sry* in species of the vole *Ellobius*. *Nat Genet* **11**, 117–118.
- Kallio, M., Eriksson, J. E., and Gorbsky, G. J. (2000). Differences in spindle association of the mitotic checkpoint protein Mad2 in mammalian spermatogenesis and oogenesis. *Dev Biol* **225**, 112–123.
- Kay, G. F., Ashworth, A., Penny, G. D., Dunlop, M., Swift, S., Brockdorff, N., and Rastan, S. (1991). A candidate spermatogenesis gene on the mouse Y chromosome is homologous to ubiquitin-activating enzyme E1. *Nature* **354**, 486–489.
- Kot, M. C., and Handel, M. A. (1990). Spermatogenesis in XO,*Sxr* mice: role of the Y chromosome. *J Exp Zool* **256**, 92–105.
- Kotula-Balak, M., Grzmil, P., Styrna, J., and Bilinska, B. (2004). Immunodetection of aromatase in mice with a partial deletion in the long arm of the Y chromosome. *Acta Histochem* **106**, 55–64.
- Lahn, B. T., and Page, D. C. (1999). Four evolutionary strata on the human X chromosome. *Science* **286**, 964–967.
- Laval, S. H., Glenister, P. H., Rasberry, C., Thornton, C. E., Mahadevaiah, S. K., Cooke, H. J., Burgoyne, P. S., and Cattanach, B. M. (1995). Y chromosome short arm-*Sxr* recombination in X*Sxr*/Y males causes deletion of *Rbm* and XY female sex reversal. *Proc Natl Acad Sci U S A* **92**, 10403–10407.
- Lee, J., Hong, J., Kim, E., Kim, K., Kim, S. W., Krishnamurthy, H., Chung, S. S., Wolgemuth, D. J., and Rhee, K. (2004). Developmental stage-specific expression of *Rbm* suggests its involvement in early phases of spermatogenesis. *Mol Hum Reprod* **10**, 259–264.
- LeMaire-Adkins, R., Radke, K., and Hunt, P. A. (1997). Lack of checkpoint control at the metaphase/anaphase transition: a mechanism of meiotic nondisjunction in mammalian females. *J Cell Biol* **139**, 1611–1619.
- Levy, E., and Burgoyne, P. S. (1986a). The fate of XO germ cells in the testes of XO/XY and XO/XY/XYY mouse mosaics: evidence for a spermatogenesis gene on the mouse Y chromosome. *Cytogenet Cell Genet* **42**, 208–213.

- Levy, E. R., and Burgoyne, P. S. (1986b). Diploid spermatids: a manifestation of spermatogenic impairment in XOSxr and T31H/+ male mice. *Cytogenet Cell Genet* **42**, 159–163.
- Mahadevaiah, S. K., Odorisio, T., Elliott, D. J., Rattigan, A., Szot, M., Laval, S. H., Washburn, L. L., McCarrey, J. R., Cattanch, B. M., Lovell-Badge, R., and Burgoyne, P. S. (1998). Mouse homologues of the human AZF candidate gene *RBM* are expressed in spermatogonia and spermatids, and map to a Y deletion interval associated with a high incidence of sperm abnormalities. *Hum Mol Genet* **7**, 715–727.
- Mazeyrat, S., Saut, N., Grigoriev, V., Mahadevaiah, S. K. M., Ojarikre, O. A., Rattigan, A., Bishop, C., Eicher, E. M., Mitchell, M. J., and Burgoyne, P. S. (2001). A Y-encoded subunit of the translation initiation factor Eif2 is essential for mouse spermatogenesis. *Nat Genet* **29**, 49–53.
- Mazeyrat, S., Saut, N., Sargent, C. A., Grimmond, S., Longepied, G., Ehrmann, I. E., Ellis, P. S., Greenfield, A., Affara, N. A., and Mitchell, M. J. (1998). The mouse Y chromosome interval necessary for spermatogonial proliferation is gene dense with syntenic homology to the human *AZF*a region. *Hum Mol Genet* **7**, 1713–1724.
- McLaren, A., Simpson, E., Epplen, J. T., Studer, R., Koopman, P., Evans, E. P., and Burgoyne, P. S. (1988). Location of the genes controlling H-Y antigen expression and testis determination on the mouse Y chromosome. *Proc Natl Acad Sci U S A* **85**, 6442–6445.
- McLaren, A., Simpson, E., Tomonari, K., Chandler, P., and Hogg, H. (1984). Male sexual differentiation in mice lacking H-Y antigen. *Nature* **312**, 552–555.
- Mitchell, M., Woods, D. R., Wilcox, S. A., Graves, J. A. M., and Bishop, C. E. (1992). Marsupial Y chromosome encodes a homologue of the mouse Y-linked candidate spermatogenesis gene *Ube1y*. *Nature* **359**, 528–531.
- Mitchell, M. J. (2000). Spermatogenesis and the mouse Y chromosome: specialisation out of decay. In: *The Genetic Basis of Male Infertility*, K. McElreavy, ed., Springer-Verlag, Berlin & Heidelberg, pp. 233–270.
- Mitchell, M. J., Wilcox, S. A., Watson, J. M., Lerner, J. L., Woods, D. R., Scheffler, J., Hearn, J. P., Bishop, C. E., and Graves, J. A. M. (1998). The origin and loss of the ubiquitin activating enzyme gene on the mammalian Y chromosome. *Hum Mol Genet* **7**, 429–434.
- Mitchell, M. J., Woods, D. R., Tucker, P. K., Opp, J. S., and Bishop, C. E. (1991). Homology of a candidate spermatogenic gene from the mouse Y chromosome to the ubiquitin-activating enzyme E1. *Nature* **354**, 483–486.
- Moriwaki, K., Suh, D.-S., and Styrna, J. (1988). Genetic factors effecting sperm morphology in the mouse. *Mouse News Letter* **82**, 138.
- Murphy, W. J., Eizirik, E., Johnson, W. E., Zhang, Y. P., Ryder, O. A., and O'Brien, S. J. (2001). Molecular phylogenetics and the origins of placental mammals. *Nature* **409**, 614–618.
- Oh, B., Hampl, A., Eppig, J. J., Solter, D., and Knowles, B. B. (1998). SPIN, a substrate in the MAP kinase pathway in mouse oocytes. *Mol Reprod Dev* **50**, 240–249.
- Oh, B., Hwang, S.-Y., Solter, D., and Knowles, B. (1997). Spindlin, a major maternal transcript expressed in the mouse during the transition from oocyte to embryo. *Development* **124**, 493–503.
- Perry, J., Palmer, S., Gabriel, A., and Ashworth, A. (2001). A short pseudoautosomal region in laboratory mice. *Genome Res* **11**, 1826–1832.

- Petronczki, M., Siomos, M. F., and Nasmyth, K. (2003). Un menage a quatre: the molecular biology of chromosome segregation in meiosis. *Cell* **112**, 423–440.
- Prado, V. F., Lee, C.-H., Zahed, L., Vekemans, M., and Nishioka, Y. (1992). Molecular characterization of a mouse Y chromosomal repetitive sequence that detects transcripts in the testis. *Cytogenet Cell Genet* **61**, 87–90.
- Rohozinski, J., Agoulnik, A. I., Boettger-Tong, H. L., and Bishop, C. E. (2002). Successful targeting of mouse Y chromosome genes using a site-directed insertion vector. *Genesis* **32**, 1–7.
- Rozen, S., Skaletsky, H., Marszalek, J. D., Minx, P. J., Cordum, H. S., Waterston, R. H., Wilson, R. K., and Page, D. C. (2003). Abundant gene conversion between arms of palindromes in human and ape Y chromosomes. *Nature* **423**, 873–876.
- Rubinson, D. A., Dillon, C. P., Kwiatkowski, A. V., Sievers, C., Yang, L., Kopinja, J., Rooney, D. L., Ihrig, M. M., McManus, M. T., Gertler, F. B., *et al.* (2003). A lentivirus-based system to functionally silence genes in primary mammalian cells, stem cells and transgenic mice by RNA interference. *Nat Genet* **33**, 401–406.
- Sandstedt, S. A., and Tucker, P. K. (2004). Evolutionary strata on the mouse X chromosome correspond to strata on the human X chromosome. *Genome Res* **14**, 267–272.
- Shoji, M., Chuma, S., Yoshida, K., Morita, T., and Nakatsuji, N. (2005). RNA interference during spermatogenesis in mice. *Dev Biol* **282**, 524–534.
- Simpson, E. M., and Page, D. C. (1991). An interstitial deletion in mouse Y chromosomal DNA created a transcribed Zfy fusion gene. *Genomics* **11**, 601–608.
- Siruntawineti, J., Yamagata, K., Nakanishi, T., and Baba, T. (2002). Occurrence of small, round vesicles in the acrosome of elongating spermatids from a mouse mutant line with partial deletion of the Y chromosome. *J Reprod Dev* **48**, 513–521.
- Styrna, J., Bilinska, B., and Krzanowska, H. (2002). The effect of a partial Y chromosome deletion in B10.BR-Ydel mice on testis morphology, sperm quality and efficiency of fertilization. *Reprod Fertil Dev* **14**, 101–108.
- Styrna, J., Imai, H. T., and Moriwaki, K. (1991a). An increased level of sperm abnormalities in mice with a partial deletion of the Y chromosome. *Genet Res* **57**, 195–199.
- Styrna, J., Kilarski, W., and Krzanowska, H. (2003). Influence of the CBA genetic background on sperm morphology and fertilization efficiency in mice with a partial Y chromosome deletion. *Reproduction* **126**, 579–588.
- Styrna, J., Klag, J., and Moriwaki, K. (1991b). Influence of partial deletion of the Y chromosome on mouse sperm phenotype. *J Reprod Fertil* **92**, 187–195.
- Sutcliffe, M. J., and Burgoyne, P. S. (1989). Analysis of the testes of H-Y negative XOSxr^b mice suggests that the spermatogenesis gene (*Spy*) acts during the differentiation of the A spermatogonia. *Development* **107**, 373–380.
- Sutcliffe, M. J., Darling, S. M., and Burgoyne, P. S. (1991). Spermatogenesis in XY, XYSxr^a and XOSxr^a mice: a quantitative analysis of spermatogenesis throughout puberty. *Mol Reprod Dev* **30**, 81–89.
- Szot, M., Grigoriev, V., Mahadevaiah, S. K., Ojarikre, O. A., Toure, A., von Glasenapp, E., Rattigan, A., Turner, J. M., Elliott, D. J., and Burgoyne, P. S. (2003). Does Rbmy have a role in sperm development in mice? *Cytogenet Genome Res* **103**, 330–336.
- Tan, A. L., Rida, P. C., and Surana, U. (2005). Essential tension and constructive destruction: the spindle checkpoint and its regulatory links with mitotic exit. *Biochem J* **386**, 1–13.

- Tiepolo, L., and Zuffardi, O. (1976). Localization of factors controlling spermatogenesis in the nonfluorescent portion of the human Y chromosome long arm. *Hum Genet* **34**, 119–124.
- Touré A., Clemente, E. J., Ellis., P., Mahadevaiah, S. K., Ojarikre, O. A., Ball, P. A., Reynard, L., Loveland, K. L., Burgoyne, P. S., and Affara, N. A. (2005). Identification of novel Y chromosome encoded transcripts by testis transcriptome analysis of mice with deletions of the Y chromosome long arm. *Genome Biol* **6**, R102.
- Touré, A., Grigoriev, V., Mahadevaiah, S. K., Rattigan, A., Ojarikre, O. A., and Burgoyne, P. S. (2004a). A protein encoded by a member of the multicopy Ssty gene family located on the long arm of the mouse Y chromosome is expressed during sperm development. *Genomics* **83**, 140–147.
- Touré, A., Szot, M., Mahadevaiah, S. K., Rattigan, A., Ojarikre, O. A., and Burgoyne, P. S. (2004b). A new deletion of the mouse Y chromosome long arm associated with loss of *Ssty* expression, abnormal sperm development and sterility. *Genetics* **166**, 901–912.
- Vogt, P. H. (2005). Azoospermia factor (AZF) in Yq11: towards a molecular understanding of its function for human male fertility and spermatogenesis. *Reprod Biomed Online* **10**, 81–93.
- Wang, X. L., Mei, J., Sun, M., Hong, Y. H., and Gui, J. F. (2005). Identification of three duplicated Spin genes in medaka (*Oryzias latipes*). *Gene* **350**, 99–106.
- Wassmann, K., Nialt, T., and Maro, B. (2003). Metaphase I arrest upon activation of the Mad2-dependent spindle checkpoint in mouse oocytes. *Curr Biol* **13**, 1596–1608.
- Xia, W., Mruk, D. D., Lee, W. M., and Cheng, C. Y. (2005). Cytokines and junction restructuring during spermatogenesis — a lesson to learn from the testis. *Cytokine Growth Factor Rev* **16**, 469–493.
- Xian, M., Azuma, S., Naito, K., Kunieda, T., Moriwaki, K., and Toyoda, Y. (1992). Effect of a partial deletion of Y chromosome on in vitro fertilizing ability of mouse spermatozoa. *Biol Reprod* **47**, 549–553.

Note Added in Proof

Further analysis of older $XSxr^bO, Eif2s3y$ and $XOSry, Eif2s3y$ males has revealed that, while both show the progressive damage leading to the presence of increasing numbers of Sertoli cell-only tubules, it is only the former males that show clear evidence of the “leak” in the spermatogenic block that allows some elongated spermatids with abnormal heads to form. This indicates that genetic information remaining in Sxr^b potentiates this progression through to elongated spermatids.

This page intentionally left blank

CHAPTER 2

MALE MEIOTIC SEX CHROMOSOME INACTIVATION AND MEIOTIC SILENCING

James M. A. Turner and Paul S. Burgoyne

*MRC National Institute for Medical Research,
Division of Developmental Genetics,
The Ridgeway, Mill Hill, London NW7 1AA, UK*

Until recently, meiotic sex chromosome inactivation (MSCI) was regarded as an oddity of spermatogenesis with an ill-defined function. Recent experiments, especially those on the flatworm *Caenorhabditis elegans* and on mice, have now challenged this view. In this review, we summarize the molecular mechanisms involved in MSCI, which in mice utilizes members of the DNA repair pathway including BRCA1, ATR, and histone H2AX. MSCI is driven by the asynaptic nature of the sex chromosomes during pachytene of male meiosis, and therefore represents an example of a recently identified more general silencing mechanism — meiotic silencing of unsynapsed chromatin (MSUC) — that serves to transcriptionally repress any unsynapsed chromatin in males or females. It is well established that during pachytene, there is also a “checkpoint” response to the presence of unsynapsed chromatin; and following from studies in yeast, it is thought that the checkpoint is triggered by the presence of DNA double-strand breaks (DSBs) that remain unrepaired in unsynapsed regions. The possible links between MSUC and this pachytene checkpoint are discussed. It has recently been proposed that, in mammals, MSCI serves to provide preimplantation XX embryos with a preinactivated paternal X chromosome (imprinted XCI). New studies show that although MSCI is causally linked to a substantial degree of postmeiotic X and Y silencing in round spermatids, MSCI and imprinted XCI can be dissociated. In summary, recent studies of MSCI, in addition to clarifying the molecular basis of the epigenetic processes that lead to inactivation, have shown it to be a manifestation of a more general response to unsynapsed chromatin that may be a component of the pachytene checkpoint response and that is maintained into spermatid development.

Keywords: Spermatogenesis; XY body or sex body; X and Y transcriptional silencing; meiotic silencing; pachytene checkpoint; spermiogenesis.

Meiotic Sex Chromosome Inactivation (MSCI)

Mouse spermatogenesis is punctuated by extremes of sex chromosome transcription (Fig. 1). During the first phase, the spermatogonial mitotic divisions, the X and Y chromosomes are hyperactive, transcribing a disproportionately large number of genes when compared to the autosomes (Wang *et al.*, 2001). This is followed by entry to meiosis, at which point there is a global repression of transcription from all chromosomes as they become condensed in early meiotic prophase. However, later in prophase, during the extended pachytene stage, there is a progressive increase in transcription from the autosomes (Moore, 1971; Turner *et al.*, 2005); the X and the Y

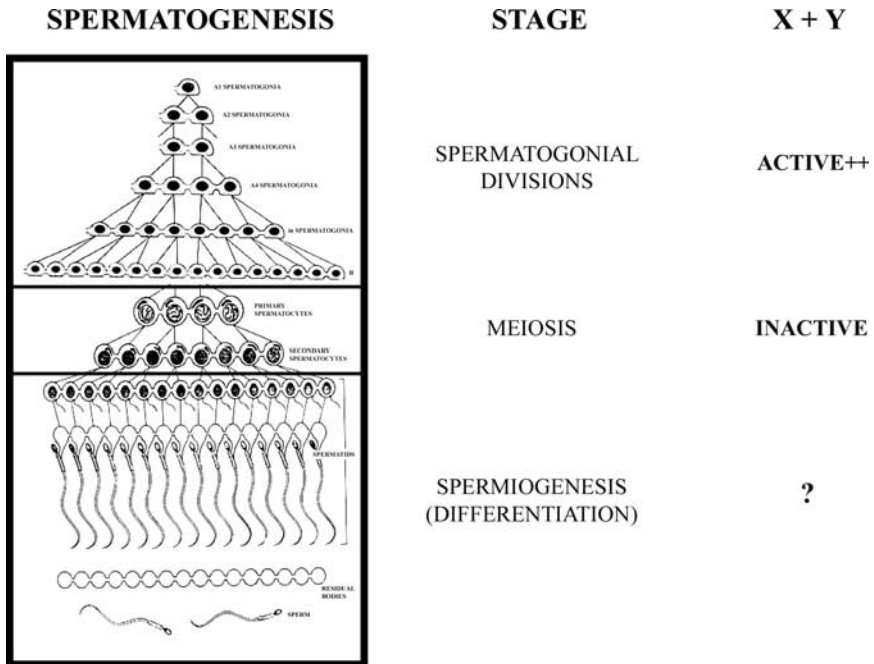

Fig. 1. Sex chromosome activity during mammalian spermatogenesis. During the spermatogonial divisions, the X and Y chromosomes are abundantly transcriptionally active. This is followed by entry into meiosis, during which both are silenced (meiotic sex chromosome inactivation, MSCI). Finally, the X and Y chromosomes are thought to be reactivated at the onset of spermiogenesis (sperm differentiation). However, whether this is true for all X and Y genes is now the subject of intense speculation.

chromosomes in contrast are subject to targeted chromatin modifications that result in transcriptional silencing (MSCI) and the formation of a heterochromatic chromatin domain called the sex body or XY body (Handel, 2004; McKee and Handel, 1993; Solari, 1974). After a brief further period of global repression when the chromosomes become condensed during the two meiotic divisions, there is a postmeiotic resumption of active transcription at the onset of spermiogenesis (sperm differentiation); since the 1990s, this has been thought to apply equally to the autosomes and the X and Y chromosomes (Hendriksen, 1999; Hendriksen *et al.*, 1995).

MSCI represents one of the biggest mysteries in germ cell epigenetics. Unlike somatic X chromosome inactivation (XCI), which is restricted to mammals and functions to equalize the expressed dose of most X-linked genes between males and females, MSCI is highly conserved, occurring in multiple phyla (including mammals, insects, and flatworms), yet its role has remained an enigma (McKee and Handel, 1993). Even more curiously, the behavior of the sex chromosomes during male meiosis is the reverse of that observed in the female. In mammalian oögonia, one X chromosome is transcriptionally silent, but this is reactivated at or before entry to meiosis, so that — in contrast to male meiotic cells, which have no active X chromosome — oocytes have two (Monk and McLaren, 1981).

So, what might be the role of MSCI in male fertility? An early suggestion was that X-gene products might be toxic to male meiotic cells, and that MSCI prevented the expression of these genes (Lifschytz and Lindsley, 1972). This suggestion has now been largely discounted for a number of reasons, in particular the fact that organisms with MSCI have gone to great lengths to compensate for the loss of X-gene products. Thus, there is hyperactivation of the X chromosome prior to MSCI (Church, 1979; Wang *et al.*, 2001), increased stability of some X-gene products (Shannon and Handel, 1993), and the activation of autosomally encoded X-derived retrogenes (McKee and Handel, 1993; Wang, 2004; but see Banks *et al.*, 2003).

As an alternative, Jablonka and Lamb (1988) proposed that MSCI “protects” the X and Y chromosomes from checkpoint responses to asynapsed chromosome regions during pachytene that lead to cell cycle arrest and/or apoptosis. The X and Y chromosomes, due to restriction of homology to the pseudoautosomal region (PAR), have extensive regions of asynapsis during pachytene; Jablonka and Lamb (1988) reasoned that MSCI serves to “mask” these unsynapsed regions so they do not trigger the synapsis checkpoint.

Under their model, X chromosome reactivation in female meiosis is perceived to be necessary in order to ensure full X-X synapsis, without which the single, active, unsynapsed X chromosome would trigger the synapsis checkpoint. We have been committed supporters of this model and have suggested that MSCI may also serve to focus the presynaptic homology search on the X and Y PARs, thus ensuring efficient X-Y pairing despite the limited region of homology (Turner *et al.*, 2000).

McKee and Handel (1993), on the other hand, proposed that MSCI might serve to prevent DNA double-strand break (DSB) formation in the non-PAR regions (the “antirecombination” model). Since these regions have no homolog with which to recombine, they argued that such breaks might remain unrepaired or, even worse, might lead to ectopic exchange events, causing chromosome rearrangements and aneuploidy. Recently, Wu and Xu (2003) formulated the sexually antagonistic X inactivation (SAXI) hypothesis, in which they reasoned that the greater amount of time that the X chromosome spends in the female than in the male results in the loss of male-enhancing (spermatogenesis) genes, and that this eventually results in large-scale silencing of the X chromosome in the male germ line (MSCI). We will return to discuss the relative merits and pitfalls of each of these models in light of the recent developments in our understanding of MSCI, as presented in the next two sections.

Molecular Genetics of MSCI

The basic unit of eukaryotic chromatin is the nucleosome, which comprises 147 base pairs of DNA wrapped around an octamer of histones. The addition of specific posttranslational modifications (e.g. phosphorylation, methylation, and acetylation) to the N-termini of histones creates changes in chromatin conformation that can positively or negatively influence gene transcription (Jenuwein and Allis, 2001; Lachner and Jenuwein, 2002). A number of histone modifications associated with transcriptional repression have been found enriched in the sex body (see Table 1 and references therein). A key modification in the context of MSCI is serine-139 phosphorylation of the histone H2A subtype H2AX. In mitotic cells, H2AX phosphorylation occurs rapidly in response to DNA DSB induction, and is essential for the recruitment of a subset of DNA repair proteins to the site

Table 1. Proteins localizing to the sex body (adapted from Handel, 2004). Note that many proteins involved in synapsis and recombination (e.g. SCP3, RAD51) also localize to the sex chromosomes, but do not necessarily function in MSCI.

Category	Examples	References
Histone modifications and chromatin-binding proteins	γ H2AX	Fernandez-Capetillo <i>et al.</i> (2003); Mahadevaiah <i>et al.</i> (2001); Turner <i>et al.</i> (2004)
	uH2A	Baarends <i>et al.</i> (1999)
	macroH2A1.2	Hoyer-Fender <i>et al.</i> (2000); Turner <i>et al.</i> (2001)
	dimH3K9	Cowell <i>et al.</i> (2002); Khalil <i>et al.</i> (2004); Peters <i>et al.</i> (2001)
	HP1 β (M31)	Motzkus <i>et al.</i> (1999); Turner <i>et al.</i> (2001)
Chromatin-modifying enzymes	SUV39H2	O'Carroll <i>et al.</i> (2000)
Others	XY40	Smith and Benavente (1992)
	XMR*	Calenda <i>et al.</i> (1994)
	p51	Smith and Benavente (1995)
	XY77	Kralewski <i>et al.</i> (1997)
	GCNF	Bauer <i>et al.</i> (1998)
	XYbp	Parraga and del Mazo (2000)
	SUMO	Rogers <i>et al.</i> (2004)
	BRCA1	Turner <i>et al.</i> (2004)
ATR	Turner <i>et al.</i> (2004)	

of the break (Paull *et al.*, 2000; Rogakou *et al.*, 1998). In male meiosis, during leptotene, H2AX phosphorylation occurs throughout the chromatin of both the autosomes and the sex chromosomes, as a predictable response to the formation of the programmed DNA DSBs that initiate meiotic recombination (Mahadevaiah *et al.*, 2001); later, at the zygotene to pachytene transition, a second wave of H2AX phosphorylation takes place that is restricted to the sex chromosomes (Turner *et al.*, 2005). Importantly, this second wave of phosphorylation immediately precedes the formation of the sex body, and this has led to the suggestion that H2AX phosphorylation is the initiating event in MSCI (Mahadevaiah *et al.*, 2001). Consistent with this hypothesis, H2AX knockout male mice are sterile; this is associated with a complete failure of MSCI and sex body formation (Fernandez-Capetillo *et al.*, 2003).

Which kinase phosphorylates H2AX in the context of MSCI? In mitotic cells, H2AX is phosphorylated by members of the PI3K-like kinase

family: ATR, ATM, and DNA-PK (Lowndes and Toh, 2005). All three kinases have been detected in meiotic cells by immunofluorescence; but only one, ATR, has been shown in multiple, independent studies to localize to the sex chromosomes, and its appearance there coincides temporally with H2AX phosphorylation (Featherstone and Jackson, 1999; Keegan *et al.*, 1996; Moens *et al.*, 1999; Turner *et al.*, 2004). By studying specific PI3K-targeted mutants, Bellani *et al.* (2005) have found that both DNA-PK and ATM are dispensable for H2AX phosphorylation in the sex chromosome domain. Although the PI3K kinases may have overlapping functions in MSCI, these findings strongly implicate ATR as an essential kinase in this process.

Since homozygous disruption of the *Atr* gene results in embryonic lethality (Brown and Baltimore, 2000), a formal test of the requirement of ATR in MSCI is currently unavailable. However, further indirect support has come from a recent study (Turner *et al.*, 2004) that described a role for the tumor suppressor BRCA1 in MSCI. Like ATR, BRCA1 localizes to the sex chromosomes at the point of initiation of MSCI. In mice with an in-frame deletion of *Brcal* exon 11, localization of ATR to the sex chromosomes is defective: only rarely is there localization to the X and Y chromatin domain; instead, ATR is usually found at multiple ectopic sites throughout the nucleus. Consistent with ATR being responsible for H2AX phosphorylation in the context of MSCI, sex chromosome H2AX phosphorylation only occurs in those rare cells where ATR localizes to the sex chromosomes; in the majority of cells, H2AX phosphorylation is found exclusively at the ectopic sites of ATR accumulation, and in these cells there is MSCI failure. This finding led us to propose a model in which BRCA1 orchestrates MSCI by recruiting ATR to the sex chromosome domain, where ATR phosphorylates H2AX, triggering MSCI (Fig. 2).

A notable feature of BRCA1, ATR, and H2AX is that they are involved not only in MSCI, but also in meiotic recombination (Celeste *et al.*, 2002; Grushcow *et al.*, 1999; Xu *et al.*, 2003). This raises the question as to whether these two processes are linked. Interestingly, a number of recombination mutants (e.g. *Dmc1*, *Msh5*, and *Sycp1*) exhibit defects in MSCI; although the reason for this relationship is unclear, it has been suggested that stalled recombination intermediates might sequester BRCA1 and ATR, thus making them unavailable for relocation to the XY bivalent at the time of MSCI (Barchi *et al.*, 2005; de Vries *et al.*, 2005).

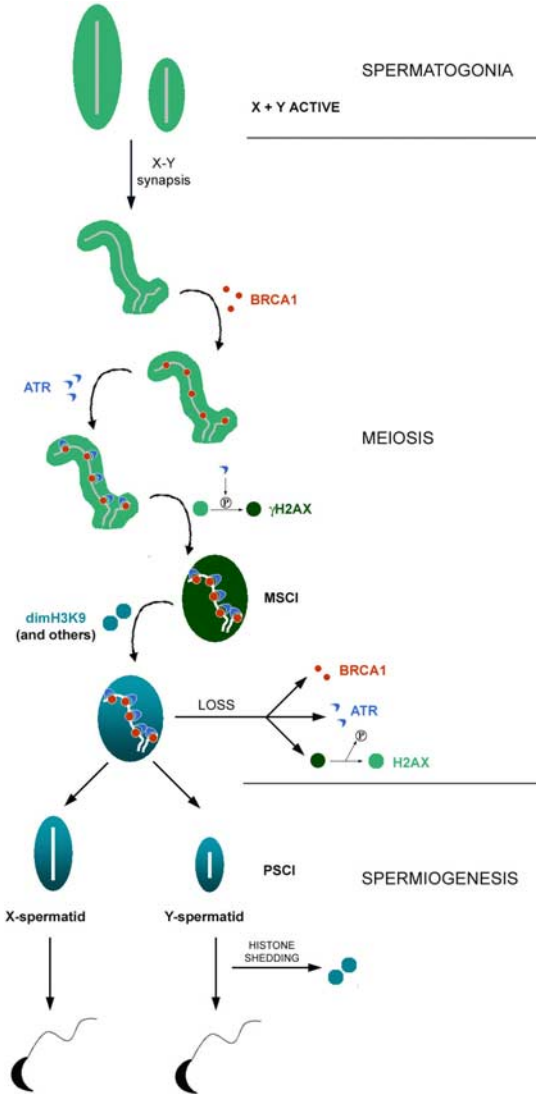

Fig. 2. A schematic representation of MSCI.

MSCI as a Special Example of a General Meiotic Silencing Mechanism

Although events upstream of H2AX phosphorylation in the MSCI pathway are becoming progressively clearer, a fundamental question remains;

namely, how does the MSCI machinery recognize and target the sex chromosomes? The answer to this question has recently been uncovered by studies on flatworms, mice, and fungi, and has unexpectedly revolutionized our understanding of the purpose of MSCI.

In flatworm meiosis, dimH3K9 is enriched on the single X chromosome in XO males, but not on the XX bivalent in hermaphrodites (Kelly *et al.*, 2002). In order to establish whether targeting of dimH3K9 to the X chromosome was specific to the male germ line or to the existence of an XO karyotype, Bean *et al.* (2004) studied this modification in *tra-2* mutants, which have an XX genotype but develop as males, and in *her-1* mutants, which have an XO genotype but develop as hermaphrodites. Unexpectedly, they found that the XX bivalent in *tra-2* males was not enriched in dimH3K9, while the single X in *her-1* hermaphrodites was. This finding demonstrated that the presence of a single X chromosome, rather than germ line sex, was predictive of dimH3K9 targeting. The authors then asked whether the single X in XO male flatworms was enriched in dimH3K9 during pachytene because it was unpaired. If so, then unpaired chromosomes in general might be expected to exhibit the same histone modification. This was indeed the case — dimH3K9 was also seen on unpaired autosomes in flatworms with free autosomal duplications and in those with widespread autosomal pairing failure, such as the *him-3* synaptonemal complex mutant (Bean *et al.*, 2004).

Shortly afterwards, similar observations were reported in mammals. Two studies found that proteins or protein modifications normally restricted to the sex body — namely BRCA1, ATR, γ H2AX, and ubiquitinated histone H2A — were also enriched on unsynapsed autosomes in males and on the unsynapsed single X chromosome in XO females (Baarends *et al.*, 2005; Turner *et al.*, 2005). The two groups used different techniques to determine the transcriptional competence of these unsynapsed chromosomes: Baarends *et al.* (2005) studied RNA polymerase II antibody staining, while Turner *et al.* (2005) used Cot1 RNA FISH, which detects sites of nascent transcription. Using these complementary approaches, both groups discovered that unsynapsed chromosomes are transcriptionally silenced. Taken together, these findings in the flatworm and mouse demonstrate that a mechanism operates during meiosis that silences unsynapsed chromosomes — a process that, in mammals, we now call meiotic silencing of unsynapsed chromatin (MSUC), reflecting the fact that the silencing is mediated at the

level of chromatin and apparently spreads to include the chromatin loops associated with regions of asynapsis (Schimenti, 2005).

The data of Bean *et al.* (2004) also show that, in flatworms, MSCI is simply an MSUC response to the presence of the single X chromosome present during normal male meiosis. We postulated that this is also true in mammals (Turner *et al.*, 2005), and our recent data has confirmed that this is indeed the case: in sex chromosome-variant mice, in which the X and/or Y chromosome is “forced” to synapse, the corresponding sex chromosome escapes MSCI (Turner *et al.*, 2006).

While the discovery of MSUC represents an important step forward for our understanding of MSCI, the concept of meiotic silencing is not altogether novel. A related process, meiotic silencing by unpaired DNA (MSUD), had already been described by Shiu *et al.* (2001) some years previously. They found that in the fungus *Neurospora crassa*, transgenes present in the hemizygous state, and hence unpaired during meiosis, were subject to silencing. Furthermore, this silencing led to the silencing of all homologous DNA sequences, whether those sequences were unpaired or not. This second property represents one important distinction between MSUD and MSUC: silencing of the X and Y chromosomes in mouse meiosis does not lead to silencing of autosomally located X- and Y-bearing transgenes (Schimenti, 2005). In addition, while MSUC silences genes at the level of transcription initiation, MSUD is thought to be posttranscriptional, since it requires an RNA-dependent RNA polymerase (RdRP) *sad-1* (Shiu *et al.*, 2001). RdRPs function in RNA interference (RNAi) by converting single-stranded RNA precursors into double-stranded RNA, which are subsequently cleaved by Dicer to form short interfering RNAs (siRNAs). These small RNA molecules guide destruction of homologous mRNA via an argonaute-containing protein complex RISC (RNA-induced silencing complex) (Dawe, 2004). The argonaute-like protein Sms-2 has been shown to be essential for meiotic silencing in *Neurospora crassa*, further supporting an RNAi-mediated mechanism of silencing in this organism (Lee *et al.*, 2003). In flatworms, meiotic silencing also involves an RdRP, *ego-1*, which is required for targeting of dimH3K9 to unpaired DNA (Lee *et al.*, 2003). Although this targeting is independent of Dicer, the question of whether meiotic silencing operates at the transcriptional and/or posttranscriptional level in this organism remains an open question.

The Role of MSCI Reconsidered

The recent rapid developments in our understanding of MSCI necessitate a reassessment of the various hypotheses that exist to explain MSCI function. It is now unlikely that MSCI “protects” the X and Y chromosomes from a putative pachytene checkpoint (the “synapsis checkpoint” model of Jablonka and Lamb, 1988). In male mice with translocations that give rise to autosomal synaptic failure, such as T(X;16)16H, the unsynapsed autosomal segments are silenced and incorporated into the sex body along with the X and Y chromosomes (Turner *et al.*, 2005). Despite this, there is substantial loss of germ cells during pachytene (Odorisio *et al.*, 1998), demonstrating that MSUC does not “mask” unsynapsed chromosomal regions. MSCI equally cannot protect the X and the Y chromosomes from DNA DSB induction (the “antirecombination” model of McKee and Handel, 1993): γ H2AX and RAD51 immunoanalysis has revealed that DNA DSBs are formed prior to the initiation of MSCI, and that they occur both on the autosomes and on the unsynapsed segment of the X (Ashley *et al.*, 1995; Barlow *et al.*, 1997; Mahadevaiah *et al.*, 2001; Moens *et al.*, 1997). The SAXI hypothesis of Wu and Xu (2003) — which considers MSCI to be a consequence of the “feminization” of the X chromosome, leading to a gradual loss of male-enhancing genes — can also be rejected on two counts. First, the hypothesis does not address why the Y chromosome is also subject to MSCI, although it is exclusively in the male and is enriched in male-fertility genes. Second, the hypothesis predicts that the X chromosome should be silenced irrespective of its synaptic status, but the fact that the X chromosome inappropriately transcribes during meiosis when it is forced to synapse clearly shows that this is not the case (Turner *et al.*, 2006).

In light of the fact that MSCI is an MSUC response to the presence of unsynapsed sex chromosomes, the question that we should now be asking is this: what is the role of MSUC? As discussed by Shiu *et al.* (2001), the formation of programmed DSBs during meiosis renders the genome especially vulnerable to invasion by transposable elements. They speculated that MSUD might act as a means of genome defense by recognizing integrating transposons as hemizygous and thereafter silencing them. However, while single-copy transgenes trigger MSUD in *Neurospora*, the same is not the case for MSUC in mammals — even large chromosome segments can

undergo nonhomologous synapsis and thereby escape MSUC (Baarends *et al.*, 2005; Turner *et al.*, 2005).

Another possibility is that MSUC provides a “checkpoint” function during meiosis. In both mammals and *S. cerevisiae*, errors in chromosome synapsis and/or recombination cause meiotic arrest via a so-called “pachytene checkpoint”. In *S. cerevisiae*, this comprises a series of signaling pathways that culminate in inactivation of the cyclin-dependent kinase *cdc28* and reduced synthesis of cyclin Clb1 (Roeder and Bailis, 2000). In mice, a comparable checkpoint cascade has yet to be identified. Furthermore, it is difficult to conceive how a mechanism that senses asynapsis and transduces it into cell cycle arrest could exist in male mouse meiosis, in which asynapsis of the non-PAR regions of the X and Y chromosomes is a normal event. Shiu *et al.* (2001) have suggested that MSUC in itself is sufficient to cause meiotic arrest because genes residing within unsynapsed chromosome regions, some of which might be essential for normal meiotic progression, will be subject to silencing, thus effectively creating a null allele.

Readdressing the Ontogeny of MSCI

According to the prevailing view, MSCI is transient, beginning at pachytene and ending before cells enter spermatid development or spermiogenesis (Fig. 2). This belief is based mainly on the fact that some genes subject to MSCI — such as *Ube1x*, *Ube1y*, and *Rbmy* — are reactivated in spermatids (Hendriksen *et al.*, 1995; Mahadevaiah *et al.*, 1998; Odorisio *et al.*, 1996; Wang *et al.*, 2005), and has been reinforced by the observation that a number of proteins implicated in MSCI (e.g. γ H2AX) disappear from the X and Y on entering the first meiotic division (Mahadevaiah *et al.*, 2001). However, new studies on a seemingly unrelated phenomenon, female somatic X chromosome inactivation (XCI), have stimulated a re-examination of the degree to which MSCI is reversed.

XCI in early female mouse embryos takes two forms: in the extra-embryonic tissues, it is paternally imprinted, affecting the X chromosome inherited from the father; while in the embryo proper, it is random, affecting the maternal or paternal X chromosome with equal probability. Both forms of XCI are mediated by *Xist* RNA, which coats the inactive X chromosome *in-cis* (Borsani *et al.*, 1991; Brown *et al.*, 1991; Marahrens *et al.*, 1997;

Penny *et al.*, 1996). Recently, two studies reinvestigated the timing of the onset of paternal XCI (Huynh and Lee, 2003; Okamoto *et al.*, 2004), which precedes random XCI and was originally thought to take place around 3.5 dpc. Both studies found that paternal XCI begins much earlier; but while Okamoto *et al.* (2004) reported the timing of initiation as being between the 4- and 8-cell stage, Huynh and Lee (2003) found evidence of paternal X chromosome silencing at the 2-cell stage. In light of their findings, Huynh and Lee (2003) proposed that the paternal X chromosome arrives in the female embryo in an already inactive state, and that MSCCI might therefore have been co-opted as a mechanism of dosage compensation in the preimplantation embryo. If correct, then MSCCI must be perpetuated beyond meiosis, contrary to the prevailing belief.

The preinactivation model is clearly attractive, since it removes the requirement for X chromosome reactivation between MSCCI and early female XCI. Studies on flatworms support an effect of MSCCI on imprinted XCI in offspring: in early hermaphrodite (XX) embryos, the paternal X chromosome exhibits hallmarks of transcriptional silencing that persist from fertilization until the 10–15-cell stage; but this imprint is lost at an earlier embryonic stage in hermaphrodites sired by males that lack MSCCI, such as the XX *tra-2* mutant (Bean *et al.*, 2004). Furthermore, new studies are emerging which show that the mouse X and Y chromosomes do indeed retain some degree of silencing beyond meiosis. Based on microarray data, Khil *et al.* (2004) have found that X and Y transcripts are underrepresented compared to autosomal transcripts during spermiogenesis. This has been supported by cytological observations which revealed that, in round spermatids, the X and Y chromosomes appear more heterochromatic and transcriptionally repressed than the autosomes and retain some inactivating histone modifications, among them dimH3K9 (Khalil *et al.*, 2004; Turner *et al.*, 2006; Namekawa *et al.*, 2006). This postmeiotic sex chromosome inactivation (PSCI) appears to be dependent upon MSUC, because autosomal regions that remain unsynapsed at pachytene and are thus subject to MSUC also assume the same transcriptionally repressed state in the spermatid stages. In contrast to MSCCI, however, PSCI appears to be leaky, with some genes showing mosaic expression and others complete reactivation (Turner *et al.*, 2006).

Despite these intriguing observations, the fact that the X and Y are repressed in spermatids does not prove the preinactivation hypothesis.

MSCI and XCI are mechanistically quite distinct processes, with imprinted and random XCI being dependent on *Xist* RNA, but MSCI being *Xist*-independent (McCarrey *et al.*, 2002; Turner *et al.*, 2002). Furthermore, Okamoto *et al.* (2004) have shown that transgenes which contain *Xist* and flanking X chromosome genes, but are not subject to MSCI, nevertheless subsequently undergo paternal XCI in female embryos. Thus, MSCI is not a prerequisite for imprinted paternal XCI of at least some X-linked genes. To accommodate all these observations, Reik and Ferguson-Smith (2005) have suggested that the X chromosome might in fact be inherited as preinactivated — as suggested by Huynh and Lee (2003) — but may then undergo transient reactivation when the paternal genome is reprogrammed in the newly fertilized egg, before being reactivated by *Xist*.

What other functions might PSCI serve? Ellis *et al.* (2005) have proposed that it may have evolved to counteract sex ratio distortion due to functional differences between X- and Y-bearing sperm. Male mice with deletions of the long arm of the Y chromosome (Yq) were known to give rise to litters with a skewed sex ratio in favor of females (Conway *et al.*, 1994; Moriwaki *et al.*, 1988), but the cause of this sex ratio distortion had remained unclear. Using testis microarray analysis, Ellis *et al.* (2005) made the crucial finding that these deletions cause upregulation of multiple genes mapping to the X and Y chromosomes, indicating that a gene (or genes) within Yq represses X and Y transcription. Of the gene families residing within Yq, one — *Sly* — was of particular interest, since it encodes a chromatin-binding protein with strong sequence similarity to *Xmr*, a known sex body protein (Calenda *et al.*, 1994; Touré *et al.*, 2005). The authors speculated that those sex-linked genes upregulated in the Yq mutants act as sex ratio distorters, and that *Sly* functions to repress these genes during normal spermiogenesis, thereby maintaining a normal sex ratio. Experiments are currently underway to test whether reconstituting *Sly* in Yq deletion mice reverses the X/Y gene upregulation phenotype and reinstates a normal sex ratio in offspring.

Concluding Remarks

The discovery of meiotic silencing has had a considerable influence on our understanding of MSCI and of the impact of meiotic pairing events on transcription patterns during postmeiotic germ cell development. The

studies described above have also uncovered a previously unexpected role for DNA repair proteins in chromatin silencing. In the future, it will be important to elucidate to what extent MSUC contributes to meiotic sterility in mutants with synaptic errors, and to systematically re-examine the true extent of X and Y chromosome reactivation during sperm differentiation.

Acknowledgments

J. Turner is an MRC Career Development Fellow.

References

- Ashley, T., Plug, A. W., Xu, J., Solari, A. J., Reddy, G., Golub, E. L., and Ward, D. C. (1995). Dynamic changes in Rad51 distribution on chromatin during meiosis in male and female vertebrates. *Chromosoma* **104**, 19–28.
- Baarends, W. M., Hoogerbrugge, J. W., Roest, H. P., Ooms, M., Vreeburg, J., Hoeijmakers, J. H. J., and Grootegoed, J. A. (1999). Histone ubiquitination and chromatin remodeling in mouse spermatogenesis. *Dev Biol* **207**, 322–333.
- Baarends, W. M., Wassenaar, E., van der Laan, R., Hoogerbrugge, J., Sleddens-Linkels, E., Hoeijmakers, J. H., de Boer, P., and Grootegoed, J. A. (2005). Silencing of unpaired chromatin and histone H2A ubiquitination in mammalian meiosis. *Mol Cell Biol* **25**, 1041–1053.
- Banks, K. G., Johnson, K. A., Lerner, C. P., Mahaffey, C. L., Bronson, R. T., and Simpson, E. M. (2003). Retroposon compensatory mechanism hypothesis not supported: Zfa knockout mice are fertile. *Genomics* **82**, 254–260.
- Barchi, M., Mahadevaiah, S., Di Giacomo, M., Baudat, F., de Rooij, D. G., Burgoyne, P. S., Jasin, M., and Keeney, S. (2005). Surveillance of different recombination defects in mouse spermatocytes yields distinct responses despite elimination at an identical developmental stage. *Mol Cell Biol* **25**, 7203–7215.
- Barlow, A. L., Benson, F. E., West, S. C., and Hultén, M. A. (1997). Distribution of the Rad51 recombinase in human and mouse spermatocytes. *EMBO J* **16**, 5207–5215.
- Bauer, U.-M., Schneider-Hirsch, S., Reinhardt, S., Benavente, R., and Maelicke, A. (1998). The murine nuclear orphan receptor GCNF is expressed in the XY body of primary spermatocytes. *FEBS Lett* **208**, 208–214.
- Bean, C. J., Schaner, C. E., and Kelly, W. G. (2004). Meiotic pairing and imprinted X chromatin assembly in *Caenorhabditis elegans*. *Nat Genet* **36**, 100–105.
- Bellani, M. A., Romanienko, P. J., Cairatti, D. A., and Camerini-Otero, R. D. (2005). SPO11 is required for sex-body formation, and Spo11 heterozygosity rescues the prophase arrest of *Atm*^{-/-} spermatocytes. *J Cell Sci* **118**, 3233–3245.
- Borsani, G., Tonlorenzi, R., Simmler, M. C., Dandolo, L., Arnaud, D., Capra, V., Grompe, M., Pizzuti, A., Muzny, D., Lawrence, C., *et al.* (1991). Characterization of a murine gene expressed from the inactive X chromosome. *Nature* **351**, 325–328.

- Brown, C. J., Ballabio, A., Rupert, J. L., Lafreniere, R. G., Grompe, M., Tonlorenzi, R., and Willard, H. F. (1991). A gene from the region of the human X inactivation centre is expressed exclusively from the inactive X chromosome. *Nature* **349**, 38–44.
- Brown, E. J., and Baltimore, D. (2000). *ATR* disruption leads to chromosomal fragmentation and early embryonic lethality. *Genes Dev* **14**, 397–402.
- Calenda, A., Allenet, B., Escalier, D., Bach, J.-F., and Garchon, H.-J. (1994). The meiosis-specific Xmr gene product is homologous to the lymphocyte Xlr protein and is a component of the XY body. *EMBO J* **13**, 100–109.
- Celeste, A., Petersen, S., Romanienko, P. J., Fernandez-Capetillo, O., Chen, H. T., Sedelnikova, O. A., Reina-San-Martin, B., Coppola, V., Meffre, E., Difilippantonio, M. J., *et al.* (2002). Genomic instability in mice lacking histone H2AX. *Science* **296**, 922–927.
- Church, K. (1979). The grasshopper X chromosome. II. Negative heteropycnosis, transcription activities and compartmentalization during spermatogonial stages. *Chromosoma* **71**, 359–370.
- Conway, S. J., Mahadevaiah, S. K., Darling, S. M., Capel, B., Rattigan, Á. M., and Burgoyne, P. S. (1994). Y353/B: a candidate multiple-copy spermiogenesis gene on the mouse Y chromosome. *Mamm Genome* **5**, 203–210.
- Cowell, I. G., Aucott, R., Mahadevaiah, S. K., Burgoyne, P. S., Huskisson, N., Bongiorno, S., Prantera, G., Fanti, L., Pimpinelli, S., Wu, R., *et al.* (2002). Heterochromatin, HP1 and methylation at lysine 9 of histone H3 in animals. *Chromosoma* **111**, 22–36.
- Dawe, R. K. (2004). RNA interference on chromosomes. *Nat Genet* **36**, 1141–1142.
- de Vries, F. A., de Boer, E., van den Bosch, M., Baarends, W. M., Ooms, M., Yuan, L., Liu, J. G., van Zeeland, A. A., Heyting, C., and Pastink, A. (2005). Mouse Sycp1 functions in synaptonemal complex assembly, meiotic recombination, and XY body formation. *Genes Dev* **19**, 1376–1389.
- Ellis, P. J., Clemente, E. J., Ball, P., Toure, A., Ferguson, L., Turner, J. M., Loveland, K. L., Affara, N. A., and Burgoyne, P. S. (2005). Deletions on mouse Yq lead to upregulation of multiple X- and Y-linked transcripts in spermatids. *Hum Mol Genet* **14**, 2705–2715.
- Featherstone, C., and Jackson, S. P. (1999). DNA double-strand break repair. *Curr Biol* **9**, R759–R761.
- Fernandez-Capetillo, O., Mahadevaiah, S. K., Celeste, A., Romanienko, P. J., Camerini-Otero, R. D., Bonner, W. M., Manova, K., Burgoyne, P., and Nussenzweig, A. (2003). H2AX is required for chromatin remodeling and inactivation of sex chromosomes in male mouse meiosis. *Dev Cell* **4**, 497–508.
- Grushcow, J. M., Holzen, T. M., Park, K. J., Weinert, T., Lichten, M., and Bishop, D. K. (1999). *Saccharomyces cerevisiae* checkpoint genes MEC1, RAD17 and RAD24 are required for normal meiotic recombination partner choice. *Genetics* **153**, 607–620.
- Handel, M. A. (2004). The XY body: a specialized meiotic chromatin domain. *Exp Cell Res* **296**, 57–63.
- Hendriksen, P. J. (1999). Do X and Y spermatozoa differ in proteins? *Theriogenology* **52**, 1295–1307.
- Hendriksen, P. J. M., Hoogerbrugge, J. W., Themmen, A. P. N., Koken, M. H. M., Hoeymakers, J. H. J., Oostra, B. A., van der Lende, T., and Grootegoed, J. A. (1995). Postmeiotic transcription of X and Y chromosomal genes during spermatogenesis in the mouse. *Dev Biol* **170**, 730–733.

- Hoyer-Fender, S., Costanzi, C., and Pehrson, J. R. (2000). Histone macroH2A1.2 is concentrated in the XY-body by the early pachytene stage of spermatogenesis. *Exp Cell Res* **258**, 254–260.
- Huynh, K. D., and Lee, J. T. (2003). Inheritance of a pre-inactivated paternal X chromosome in early mouse embryos. *Nature* **426**, 857–862.
- Jablonska, E., and Lamb, M. J. (1988). Meiotic pairing constraints and the activity of sex chromosomes. *J Theor Biol* **133**, 23–36.
- Jenuwein, T., and Allis, C. D. (2001). Translating the histone code. *Science* **293**, 1074–1080.
- Keegan, K. S., Holtzman, D. A., Plug, A. W., Christenson, E. R., Brainerd, E. E., Flaggs, G., Bentley, N. J., Taylor, E. M., Meyn, M. S., Moss, S. B., *et al.* (1996). The Atr and Atm protein kinases associate with different sites along meiotically pairing chromosomes. *Genes Dev* **10**, 2423–2437.
- Kelly, W. G., Schaner, C. E., Dernburg, A. F., Lee, M. H., Kim, S. K., Villeneuve, A. M., and Reinke, V. (2002). X-chromosome silencing in the germline of *C. elegans*. *Development* **129**, 479–492.
- Khalil, A. M., Boyar, F. Z., and Driscoll, D. J. (2004). Dynamic histone modifications mark sex chromosome inactivation and reactivation during mammalian spermatogenesis. *Proc Natl Acad Sci U S A* **101**, 16583–16587.
- Khil, P. P., Smirnova, N. A., Romanienko, P. J., and Camerini-Otero, R. D. (2004). The mouse X chromosome is enriched for sex-biased genes not subject to selection by meiotic sex chromosome inactivation. *Nat Genet* **36**, 642–646.
- Kralewski, M., Novello, A., and Benavente, R. (1997). A novel Mr 77,000 protein of the XY body of mammalian spermatocytes: its localization in normal animals and in Searle's translocation carriers. *Chromosoma* **106**, 160–167.
- Lachner, M., and Jenuwein, T. (2002). The many faces of histone lysine methylation. *Curr Opin Cell Biol* **14**, 286–298.
- Lee, D. W., Pratt, R. J., McLaughlin, M., and Aramayo, R. (2003). An argonaute-like protein is required for meiotic silencing. *Genetics* **164**, 821–828.
- Lifschytz, E., and Lindsley, D. (1972). The role of X-chromosome inactivation during spermatogenesis. *Proc Natl Acad Sci U S A* **69**, 182–186.
- Lowndes, N. F., and Toh, G. W. (2005). DNA repair: the importance of phosphorylating histone H2AX. *Curr Biol* **15**, R99–R102.
- Mahadevaiah, S. K., Odorisio, T., Elliott, D. J., Rattigan, A., Szot, M., Laval, S. H., Washburn, L. L., McCarrey, J. R., Cattanaach, B. M., Lovell-Badge, R., *et al.* (1998). Mouse homologues of the human *AZF* candidate gene *RBM* are expressed in spermatogonia and spermatids, and map to a Y deletion interval associated with a high incidence of sperm abnormalities. *Hum Mol Genet* **7**, 715–727.
- Mahadevaiah, S. K., Turner, J. M. A., Baudat, F., Rogakou, E. P., de Boer, P., Blanco-Rodriguez, J., Jasin, M., Keeney, S., Bonner, W. M., and Burgoyne, P. S. (2001). Recombinational DNA double-strand breaks in mice precede synapsis. *Nat Genet* **27**, 271–276.
- Marahrens, Y. B., Panning, J., Strauss, W., and Jaenisch, R. (1997). Xist-deficient mice are defective in dosage compensation but not spermatogenesis. *Genes Dev* **11**, 156–166.
- McCarrey, J. R., Watson, C., Atencio, J., Ostermeier, G. C., Marahrens, Y., Jaenisch, R., and Krawetz, S. A. (2002). X-chromosome inactivation during spermatogenesis is regulated by an Xist/Tsix-independent mechanism in the mouse. *Genesis* **34**, 257–266.

- McKee, B. D., and Handel, M. A. (1993). Sex chromosomes, recombination, and chromatin conformation. *Chromosoma* (Berlin) **102**, 71–80.
- Moens, P. B., Chen, D. J., Shen, Z., Kolas, N., Tarsounas, M., Heng, H. H. Q., and Spyropoulos, B. (1997). Rad51 immunocytology in rat and mouse spermatocytes and oocytes. *Chromosoma* **106**, 207–215.
- Moens, P. B., Tarsounas, M., Morita, T., Habu, T., Rottinghaus, S. T., Freire, R., Jackson, S. P., Barlow, C., and Wynshaw-Boris, A. (1999). The association of ATR protein with mouse meiotic chromosome cores. *Chromosoma* **108**, 95–102.
- Monk, M., and McLaren, A. (1981). X-chromosome activity in foetal germ cells of the mouse. *J Embryol Exp Morphol* **63**, 75–84.
- Moore, G. P. (1971). DNA-dependent RNA synthesis in fixed cells during spermatogenesis in mouse. *Exp Cell Res* **68**, 462–465.
- Moriwaki, K., Suh, D.-S., and Styryna, J. (1988). Genetic factors effecting sperm morphology in the mouse. *Mouse News Letter* **82**, 138.
- Motzkus, D., Singh, P. B., and Hoyer-Fender, S. (1999). M31, a murine homolog of *Drosophila* HP1, is concentrated in the XY body during spermatogenesis. *Cytogenet Cell Genet* **86**, 83–88.
- Namekawa, S. H., Park, P. J., Zhang, L. F., Shima, J. E., McCarrey, J. R., Griswold, M. D., and Lee, J. T. (2006). Post-meiotic sex chromatin in the male germline of mice. *Curr Biol* (in press).
- O'Carroll, D., Scherthan, H., Peters, A. H. F. M., Opravil, S., Haynes, A. R., Laible, G., Rea, S., Schmid, M., Lebersorger, A., Jerratsch, M., *et al.* (2000). Isolation and characterization of *Suv39h2*, a second histone H3 methyltransferase gene that displays testis-specific expression. *Mol Cell Biol* **20**, 9423–9433.
- Odoriso, T., Mahadevaiah, S. K., McCarrey, J. R., and Burgoyne, P. S. (1996). Transcriptional analysis of the candidate spermatogenesis gene *Ubel1* and of the closely related *Ubelx* shows that they are coexpressed in spermatogonia and spermatids but are repressed in pachytene spermatocytes. *Dev Biol* **180**, 336–343.
- Odoriso, T., Rodriguez, T. A., Evans, E. P., Clarke, A. R., and Burgoyne, P. S. (1998). The meiotic checkpoint monitoring synapsis eliminates spermatocytes via p53-independent apoptosis. *Nat Genet* **18**, 257–261.
- Okamoto, I., Otte, A. P., Allis, C. D., Reinberg, D., and Heard, E. (2004). Epigenetic dynamics of imprinted X inactivation during early mouse development. *Science* **303**, 644–649.
- Parraga, M., and del Mazo, J. (2000). XYbp, a novel RING-finger protein, is a component of the XY body of spermatocytes and centrosomes. *Mech Dev* **90**, 95–101.
- Paull, T. T., Rogakou, E. P., Yamazaki, V., Kirchgessner, C. U., Gellert, M., and Bonner, W. M. (2000). A critical role for histone H2AX in recruitment of repair factors to nuclear foci after DNA damage. *Curr Biol* **10**, 886–895.
- Penny, G. D., Kay, G. F., Sheardown, S. A., Rastan, S., and Brockdorff, N. (1996). Requirement for Xist in X chromosome inactivation. *Nature* **379**, 131–137.
- Peters, A. H., O'Carroll, D., Scherthan, H., Mechtler, K., Sauer, S., Schofer, C., Weipoltshammer, K., Pagani, M., Lachner, M., Kohlmaier, A., *et al.* (2001). Loss of the Suv39h histone methyltransferases impairs mammalian heterochromatin and genome stability. *Cell* **107**, 323–337.
- Reik, W., and Ferguson-Smith, A. C. (2005). Developmental biology: the X-inactivation yo-yo. *Nature* **438**, 297–298.

- Roeder, S., and Bailis, J. M. (2000). The pachytene checkpoint. *Trends Genet* **16**, 395–403.
- Rogakou, E. P., Pilch, D. R., Orr, A. H., Ivanova, V. S., and Bonner, W. M. (1998). DNA double-stranded breaks induce histone H2AX phosphorylation on serine 139. *J Biol Chem* **273**, 5858–5868.
- Rogers, R. S., Inselman, A., Handel, M. A., and Matunis, M. J. (2004). SUMO modified proteins localize to the XY body of pachytene spermatocytes. *Chromosoma* **113**, 233–243.
- Schimenti, J. (2005). Synapsis or silence. *Nat Genet* **37**, 11–13.
- Shannon, M., and Handel, M. A. (1993). Expression of the Hprt gene during spermatogenesis: implications for sex-chromosome inactivation. *Biol Reprod* **49**, 770–778.
- Shiu, P. K., Raju, N. B., Zickler, D., and Metzberg, R. L. (2001). Meiotic silencing by unpaired DNA. *Cell* **107**, 905–916.
- Smith, A., and Benavente, R. (1992). Meiosis-specific protein selectivity associated with sex chromosomes of rat pachytene spermatocytes. *Proc Natl Acad Sci USA* **89**, 6938–6942.
- Smith, A., and Benavente, R. (1995). An Mr 51,000 protein of mammalian spermatogenic cells that is common to the whole XY body and centromeric heterochromatin of autosomes. *Chromosoma* **103**, 591–596.
- Solari, A. J. (1974). The behavior of the XY pair in mammals. *Int Rev Cytol* **38**, 273–317.
- Touré, A., Clemente, E. J., Ellis, P. J. I., Mahadevaiah, S. K., Ojarikre, O. A., Ball, P. A. F., Reynard, L. N., Loveland, K. L., Burgoyne, P. S., and Affara, N. A. (2005). Identification of novel Y chromosome-encoded transcripts by testis transcriptome analysis of mice with deletions of the Y chromosome long arm. *Genome Biol* **6**, R102.
- Turner, J. M., Aprelikova, O., Xu, X., Wang, R., Kim, S., Chandramouli, G. V., Barrett, J. C., Burgoyne, P. S., and Deng, C. X. (2004). BRCA1, histone H2AX phosphorylation, and male meiotic sex chromosome inactivation. *Curr Biol* **14**, 2135–2142.
- Turner, J. M., Burgoyne, P. S., and Singh, P. B. (2001). M31 and macroH2A1.2 colocalise at the pseudoautosomal region during mouse meiosis. *J Cell Sci* **114**, 3367–3375.
- Turner, J. M., Mahadevaiah, S. K., Fernandez-Capetillo, O., Nussenzweig, A., Xu, X., Deng, C. X., and Burgoyne, P. S. (2005). Silencing of unsynapsed meiotic chromosomes in the mouse. *Nat Genet* **37**, 41–47.
- Turner, J. M. A., Mahadevaiah, S. K., Benavente, R., Offenberger, H. H., Heyting, C., and Burgoyne, P. S. (2000). Analysis of male meiotic ‘sex-body’ proteins during XY female meiosis provides new insights into their functions. *Chromosoma* **109**, 426–432.
- Turner, J. M. A., Mahadevaiah, S. K., Elliott, D. J., Garchon, H. J., Pehrson, J. R., Jaenisch, R., and Burgoyne, P. S. (2002). Meiotic sex chromosome inactivation in male mice with targeted disruptions of Xist. *J Cell Sci* **115**, 4097–4105.
- Turner, J. M. A., Mahadevaiah, S. K., Ellis, P. J. I., Mitchell, M. J., and Burgoyne, P. S. (2006). Pachytene asynapsis drives meiotic sex chromosome inactivation and leads to substantial postmeiotic repression in spermatids. *Dev Cell* (in press).
- Wang, P. J. (2004). X chromosomes, retrogenes and their role in male reproduction. *Trends Endocrinol Metab* **15**, 79–83.
- Wang, P. J., McCarrey, J. R., Yang, F., and Page, D. C. (2001). An abundance of X-linked genes expressed in spermatogonia. *Nat Genet* **27**, 422–426.
- Wang, P. J., Page, D. C., and McCarrey, J. R. (2005). Differential expression of sex-linked and autosomal germ-cell-specific genes during spermatogenesis in the mouse. *Hum Mol Genet* **14**, 2911–2918.

- Wu, C. I., and Xu, E. Y. (2003). Sexual antagonism and X inactivation — the SAXI hypothesis. *Trends Genet* **19**, 243–247.
- Xu, X., Aprelikova, O., Moens, P., Deng, C. X., and Furth, P. A. (2003). Impaired meiotic DNA-damage repair and lack of crossing-over during spermatogenesis in BRCA1 full-length isoform deficient mice. *Development* **130**, 2001–2012.

This page intentionally left blank

CHAPTER 3

INSIGHTS INTO *SRY* ACTION FROM SEX REVERSAL MUTATIONS

Melissa I. Stahle, Pascal Bernard, and Vincent R. Harley

*Prince Henry's Institute of Medical Research,
Level 4 Block E, Monash Medical Centre,
246 Clayton Road, Clayton,
Victoria 3168
Australia*

In mammals, sex determination is a process triggered by the expression of *SRY*, the Y-chromosome-encoded testis-determining gene. The *SRY* protein has a highly conserved DNA-binding domain, the HMG box containing two nuclear localization signals. Mutations in *SRY* account for 10%–15% cases of 46,XY female sex reversal with gonadal dysgenesis. Nearly all reported *SRY* clinical mutations are localized within the HMG box, and a few occur outside. These have shed insight into essential functions of the *SRY* protein for mammalian sex determination. This review focuses on *SRY* mutations and their consequences in sex determination.

Keywords: *SRY*; sex reversal; gonadal dysgenesis; HMG box; KRAB-O.

Sex Determination

In mammals, sex determination is a process by which the undifferentiated gonadal primordium (urogenital ridge) forms into either a testis or an ovary. This developmental process involves complex molecular and genetic pathways that lead to two distinctly different tissues (Fig. 1). The decisive factor influencing this step is the expression of *SRY* (sex-determining region on the Y chromosome) (Sinclair *et al.*, 1990).

Corresponding author: Vincent R. Harley; e-mail: Vincent.Harley@princehenrys.org

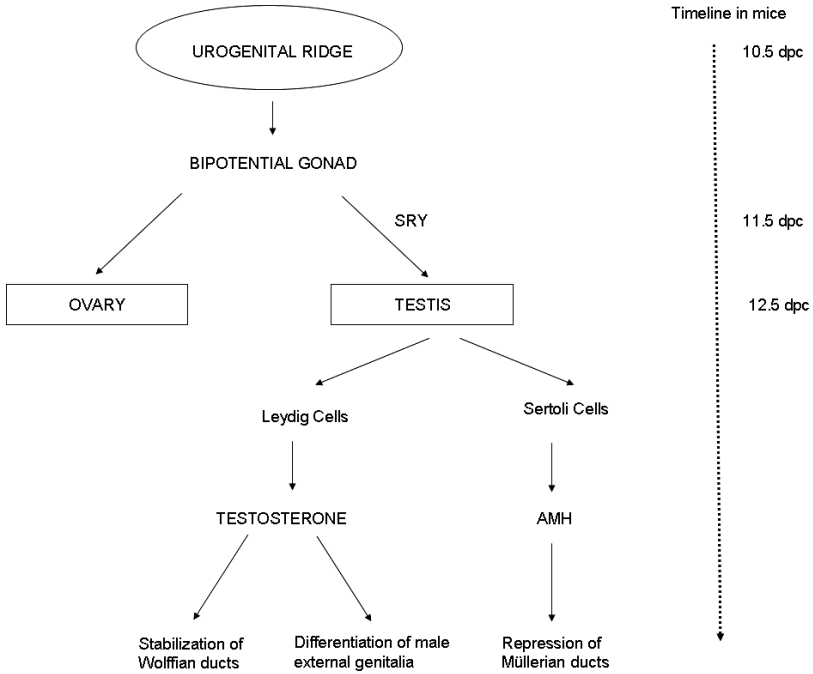

Fig. 1. Summary of genetic pathways involved in gonadal development. Mammalian sex determination occurs when development of the bipotential gonad diverges toward the testis or ovarian pathway. In the presence of SRY, the undifferentiated gonad develops into a testis. Male-specific hormones, including testosterone and AMH (anti-Müllerian hormone or Müllerian inhibitory substance, MIS), are then secreted to promote male development and further inhibit female development. Conversely, in the absence of SRY, the undifferentiated gonad develops into an ovary.

Following the sex-determining switch, the testis is organized into the testicular cords and becomes histologically distinct from the ovary (Bullejos *et al.*, 2001). Shortly thereafter, testosterone secreted by Leydig cells induces stabilization of proximal Wolffian ducts and development of internal male genitalia. The anti-Müllerian hormone (AMH) secreted by Sertoli cells then inhibits the development of female internal genitalia by repressing the differentiation of the distal Müllerian duct (Capel, 2000). Testicular tissues, and in particular seminiferous tubules, are recognized in the human embryo at 7 weeks of fetal age, while the same structures are evident at 12.5 days postcoitum (dpc) in the mouse.

SRY

Mapped to the distal region of the short arm of the human Y chromosome (Yp11.3), the human *SRY* gene is contained within a single exon and encodes a 204-amino-acid protein. Containing a central region that shares homology to a DNA-binding motif, the high mobility group (HMG) box, the DNA-binding and DNA-bending domain of SRY also contains two independent nuclear localization signals (NLSs) (Fig. 2). More recent biochemical studies have identified that the C-terminal NLS (c-NLS) is able to bind importin- β (Forwood *et al.*, 2001), whilst the N-terminal NLS (n-NLS) binds calmodulin (Sim *et al.*, 2005). The interaction with these factors may modulate nuclear import of SRY during gonadal development, an essential process for SRY function as a DNA-binding transcriptional regulatory factor. However, the HMG box, which is a common domain found in the SOX (SRY-like HMG box protein) family of proteins, may also facilitate binding to RNA and thereby induce RNA bending, thus affecting the structure of pre-mRNAs during splicing and favoring protein–RNA and RNA–RNA interactions (Ohe *et al.*, 2002).

The importance of the HMG box to SRY function can be implied from the fact that it is the only region conserved between human and murine SRY (Harley *et al.*, 1994). In addition, clinical mutations cluster within this

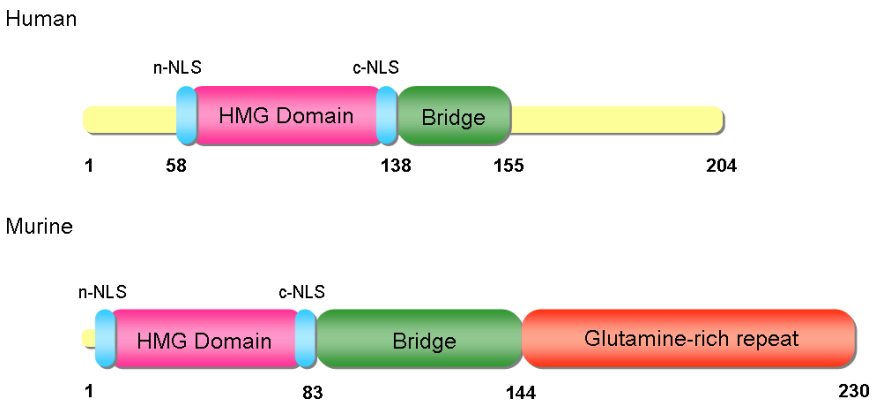

Fig. 2. Comparison of the human and mouse SRY protein domains. The protein domains of the human and mouse SRY proteins, showing the conserved HMG domain (HMG) and the glutamine-rich domain (which is present in mice, yet absent in humans).

region and are associated with 46,XY pure gonadal dysgenesis, leading to failure of testicular differentiation and female somatic phenotype.

Apart from the core HMG box, the sequence divergence of SRY is substantial, with murine SRY containing a glutamine-rich region that is absent from other mammalian species. This high degree of divergence suggests that directional selection has occurred (Whitfield *et al.*, 1993), but to what end remains unknown.

Whilst the regions on either side of the HMG box have no obvious structure or conservation, Desclozeaux and colleagues (1998) identified a protein kinase A (PKA) motif in the N-terminal region of the protein. Experimental evidence suggests that PKA phosphorylates a specific serine residue on the protein, leading to an enhanced DNA-binding activity *in vitro*.

To better understand the function of SRY, SRY-interacting proteins need to be identified. The PDZ domain of SIP-1 (SRY-interacting protein 1) has been observed *in vitro* to interact with the C-terminal seven amino acids of SRY (Poulat *et al.*, 1997). More recently, KRAB-O (Krupple-associated box only), an alternatively spliced form of KRAB zinc finger protein ZNF208, has been shown to interact *in vitro* with SRY (Oh *et al.*, 2005); this interaction involves the bridge region of SRY immediately downstream of the HMG box. Nevertheless, despite the identification of these potential interactive protein partners for SRY, whether they are capable of interacting *in vivo* to affect SRY function at the specific time of sex determination is yet to be identified.

SRY protein binds the minor groove of the DNA double helix in a sequence-specific manner, and bends the DNA by 76° (Giese *et al.*, 1992; Harley *et al.*, 1992; Pontiggia *et al.*, 1994). Such SRY-induced bending of target sequence DNA may possibly activate chromatin rearrangements in order to facilitate the binding of transcriptional machinery (Bianchi *et al.*, 1989). Alternatively, it has been hypothesized that the bend induced upon binding of SRY to regulatory regions of target genes brings together distant sites, and thereby facilitates interactions between transcription factors bound at those sites (Ferrari *et al.*, 1992). Such interactions could either initiate the male pathway by activating testis-specific genes (Lovell-Badge, 1992), repress female differentiation (Capel, 2000), or block genes which act as negative regulators of male sex determination (McElreavey *et al.*, 1993). Furthermore, it is predicted that these functions are necessary for sex

determination, as SRY mutations identified in XY females affect both the DNA-binding and DNA-bending activities (Harley *et al.*, 1992; Pontiggia *et al.*, 1994). *In vitro* binding assays have defined the high-affinity binding site to be A/T AACAA T/A (Harley *et al.*, 1994), the SOX (SRY-like HMG box) core motif. DNA-binding specificity differs between SOX proteins, due to the flanking sequence of this core motif (Harley *et al.*, 1992; Mertin *et al.*, 1999). The SRY protein can also bind *in vitro* to four-way junction DNA in a sequence-independent manner, but it is not known whether this has any biological importance (Ferrari *et al.*, 1992; Peters *et al.*, 1995).

During embryogenesis, mouse Sry is expressed in Sertoli cell precursors between 10.5 and 12.5 dpc (Gubbay *et al.*, 1990; Hacker *et al.*, 1995). This timing is critical for gonad formation and for initiation of testis development, as delayed Sry expression results in XY sex reversal (Bullejos *et al.*, 2001). Expression of Sry has also been detected in the murine brain (Mayer *et al.*, 2000), where it is predicted to regulate the transcription of the tyrosine hydroxylase gene (Milsted *et al.*, 2004).

In humans, SRY mRNA expression commences at 41 days postovulation (dpo), peaks at 44 dpo, and persists at low levels throughout the embryonic period and beyond (Hanley *et al.*, 2000).

The mechanism by which SRY initiates the differentiation of the gonad into a testis remains to be elucidated. Without the identification of direct *in vivo* targets of SRY, the molecular mechanism by which SRY initiates the cascade of steps in the male developmental pathway remains elusive and open to conjecture.

Other Human Sex-Determining Genes

Since the discovery of SRY, a number of genes have been implicated in sex determination through either positional cloning or transgenic/knock-out experiments in mice. Although it is likely that SRY is involved in the regulation of some of these genes, there is currently no conclusive evidence to support this. Genes involved in sex determination have also been identified through the mutational analysis of sex-reversed patients. What follows is a brief summary outlining the evidence implicating genes other than SRY in human sex reversal.

SOX9

Mutations in SOX9 result in a severe skeletal malformation syndrome known as campomelic dysplasia (CD), with partial or complete XY sex reversal (Foster *et al.*, 1994; Wagner *et al.*, 1994). In addition, duplication of the chromosomal region 17q23.1–q24.3 encompassing the SOX9 locus has been identified in an XX individual with female-to-male sex reversal (Huang *et al.*, 1999). However, unlike SRY mutations which predominantly cluster in the HMG domain, SOX9 sex-reversing mutations are distributed throughout the open reading frame and more or less tend to truncate SOX9.

Gonadal SOX9 has been shown to activate AMH in Sertoli cells (De Santa Barbara *et al.*, 1998). However, AMH is not required for sex determination; other SOX9 target genes must exist in the gonad, but remain to be identified. More importantly, the activation of SOX9 in the gonad is sufficient to trigger all the downstream events needed for the development of a fully fertile male even in the absence of SRY (Qin and Bishop, 2005), leading to the conclusion that SOX9 is a sex-determining gene *per se*.

SF-1

Steroidogenic factor-1 (SF-1) is an orphan nuclear hormone receptor that was identified as a key determinant of steroid hormone biosynthesis. Recently, naturally occurring SF-1 mutations have been identified in two different 46,XY individuals with complete phenotypic sex reversal, including persistent Müllerian structures and primary adrenal failure (Achermann *et al.*, 1999; Biason-Lauber and Schoenle, 2000). In addition, mice homozygous for deletion of SF-1^{-/-} have complete adrenal and gonadal agenesis, male-to-female sex reversal, and persistent Müllerian structures in males (Luo *et al.*, 1994).

These reports provide evidence that mutations in SF-1 play an important role in sexual differentiation and in the formation of primary steroidogenic tissues. However, like SOX9, SF-1 target genes in sex determination remain elusive.

DAX-1

The dosage-sensitive sex reversal region on the short arm of the X chromosome (Xp21.3) was identified by the analysis of individuals with a normal

SRY presenting with male-to-female sex reversal and adrenal hypoplasia congenita (Bardoni *et al.*, 1994). Analysis of genes present in this region led to the cloning of the DAX-1 gene, DAX-1 (dosage-sensitive sex reversal adrenal hypoplasia congenita critical region on the X chromosome gene 1) (Zanaria *et al.*, 1994).

In the developing mouse testis, the expression of Dax-1 is downregulated in males at the time of Sry activation. When duplicated, DAX-1 is responsible for male-to-female sex-reversed phenotype in humans and in transgenic mice (Swain *et al.*, 1998; Zanaria *et al.*, 1994). However, in Dax-1 knockout mice, ovarian development is not affected, suggesting that this is an “antitestis” rather than an “ovary-forming” gene (Yu *et al.*, 1998).

DHH

Desert hedgehog (DHH) is a member of the hedgehog family of signaling proteins, which also includes sonic hedgehog and Indian hedgehog (Ingham, 1998). DHH has been implicated in mammalian sex determination, as Umehara *et al.* (2000) identified a homozygous missense mutation of the DHH gene in four patients with 46,XY partial gonadal dysgenesis associated with minifascicular neuropathy. Further studies have shown that DHH is a paracrine-signaling factor which regulates fetal Leydig cell development (Yao *et al.*, 2002).

WT1

The WT1 gene was identified as a tumor-suppressor gene in Wilms' tumor (Call *et al.*, 1990; Gessler *et al.*, 1990). Based on the observation of WT1-knockout mice, WT1 is required for the development of several organs including kidney, gonad, spleen, adrenal gland, epicardium, and retina (Herzer *et al.*, 1999; Kreidberg *et al.*, 1993; Moore *et al.*, 1999). In humans, WT1 mutations are involved in human gonadal dysgenesis, which is observed in Denys–Drash syndrome (DDS) and Frasier syndrome (reviewed in Scharnhorst *et al.*, 2001). Furthermore, recent studies have shown that WT1 binds to and acts synergistically with SRY to activate transcription from a promoter containing artificial SRY-binding sites (Matsuzawa-Watanabe *et al.*, 2003).

WNT4

WNT4 was the first signaling molecule shown to be involved in sexual differentiation, and patients carrying duplication of *WNT4* have been described by several groups (Cousineau *et al.*, 1981; Elejalde *et al.*, 1984; Mohammed *et al.*, 1989). Whilst the phenotypic presentation of these patients varied from cryptorchidism to XY sex reversal, these reports drew attention at Wnt4 being involved in sex determination in humans. More recently, the first female patient carrying a heterozygous mutation in the *WNT4* gene has been reported (Biason-Lauber *et al.*, 2004). This patient presented with elevated androgens and a lack of Müllerian structures. Using mouse models, several groups have shown that Wnt4 represses steroidogenesis in females by either repressing SF1 function or preventing migration into the gonad of steroidogenic cell precursors (Jeays-Ward *et al.*, 2003; Jordan *et al.*, 2003; Vainio *et al.*, 1999).

Additional loci

Other loci have been implicated in sex reversal, and may account in part for the 85%–90% of XY gonadal dysgenesis not attributed to mutations in *SRY*. These loci map to chromosome 2q (Slavotinek *et al.*, 1999), unbalanced translocations involving the chromosomal region 6p25 (Batanian *et al.*, 2001), terminal deletion of 10q (Wilkie *et al.*, 1993), and partial duplication of chromosome 22q (Aleck *et al.*, 1999). However, to date, no genes have been identified within these loci.

Clinical Mutations of *SRY*

Sex reversal occurs when genes involved in the sex differentiation pathway are disrupted. Whilst the *SRY* protein is assumed to play the pivotal role in the regulation of genes involved in the male pathway, mutations in *SRY* account for only 10%–15% cases of 46,XY female gonadal dysgenesis (Cameron and Sinclair, 1997). This implies that other sex-determining genes remain to be identified.

To date, 72 mutations — including point mutations, frameshifts, and deletions — have been identified within the *SRY* open reading frame (Table 1). The majority of mutations in *SRY* are located in the HMG domain,

Table 1. Mutations in the SRY gene.

Phenotype	Nomenclature	SRY Mutation	Inheritance	Reference
Upstream HMG box				
Partial GD	Q2X	CAA-TAA	–	Brown <i>et al.</i> (1998)
Sex reversal	V3L	GTG-CGT	n.a.	Berta <i>et al.</i> (1990)
Pure GD	Y4X	TAT-TAA	–	Veitia <i>et al.</i> (1997)
Pure GD	Y4fsX	1 base deletion T, at nucleotide 12	–	Takagi <i>et al.</i> (1999)
Pure GD	R5G	CGA-GGA	–	Affara <i>et al.</i> (1993)
Sex reversal	M7I	ATG-ATA	n.a.	Berta <i>et al.</i> (1990)
Pure GD	Y13X	TGG-TAG	–	Hawkins <i>et al.</i> (1992a)
Sex reversal	E17X	CAG-TAG	n.a.	Affara <i>et al.</i> (1993)
Partial GD	S18N	AGT-AAT	+	Domenice <i>et al.</i> (1998)
Pure GD	M21T	ATG-ACG	–	Affara <i>et al.</i> (1993)
Pure GD	R30I	AGA-ATA	+	Assumpcao <i>et al.</i> (2002)
Pure GD	I33M	ATC-ATG	–	Hawkins <i>et al.</i> (1992b)
TH	L35H	CTT-CAT	+	Braun <i>et al.</i> (1993)
Pure GD	E38G	GAA-GAG	–	Zhou <i>et al.</i> (2005)
Pure GD	E38Q	GAA-CAA	–	Hawkins <i>et al.</i> (1992a)
Pure GD	K43fsX43	1 base insertion T, at nucleotide 126	–	Scherer <i>et al.</i> (1998)
Pure GD	Q57R	CAG-CGG	–	Shahid <i>et al.</i> (2004)
Within HMG box				
Pure GD	R59G	AGA-GGA	–	Fernandez <i>et al.</i> (2002)
TH	V60A	GTG-GCG	–	Hiort <i>et al.</i> (1995)
Pure GD	V60L	GTG-CTG	+	Berta <i>et al.</i> (1990)
Pure GD	R62G	CGA-GGA	–	Affara <i>et al.</i> (1993)
Pure GD	M64R	ATG-AGG	–	Scherer <i>et al.</i> (1998)
Pure GD	M64I	ATG-ATA	–	Berta <i>et al.</i> (1990)
Pure GD	N65H	AAC-CAC	–	Assumpcao <i>et al.</i> (2002)
Pure GD	F67V	TTC-GTC	+	Scherer <i>et al.</i> (1998)
Pure GD	F67V	TTC-GTC	+	Hines <i>et al.</i> (1997)
Pure GD	F67L	TTC-CTC	–	Zenteno <i>et al.</i> (2003)
Pure GD	I68T	ATC-ACC	–	McElreavey <i>et al.</i> (1992a)
Sex reversal	W70X	TGG-TAG	–	Hawkins <i>et al.</i> (1992a)
Pure GD	R72G	CGC-GGC	–	Baldazzi <i>et al.</i> (2003)
Pure GD	Q74X	CAG-TAG	+	Affara <i>et al.</i> (1993)
Partial GD	Q74H	CAG-CAC	–	Shahid <i>et al.</i> (2005)
Pure GD	R75N	AGG-AAT	–	Battiloro <i>et al.</i> (1997)
Pure GD	R76Y	CGC-TGC	n.a.	Affara <i>et al.</i> (1993)

(Continued)

Table 1. (Continued)

Phenotype	Nomenclature	SRY Mutation	Inheritance	Reference
Sex reversal	R76P	CGC-CCC	n.a.	Zhi <i>et al.</i> (1996)
Pure GD	R76S	CGC-AGC	+	Imai <i>et al.</i> (1999)
Pure GD	M78T	ATG-ACG	-	Affara <i>et al.</i> (1993)
TH	A79A	GCT-GCC	-	Braun <i>et al.</i> (1993)
Pure GD	N82fsX179	1 base deletion A, at nucleotide 244	-	Kellermayer <i>et al.</i> (2005)
Pure GD	N82fsX	1 base insertion T, at nucleotide 244	-	Shahid <i>et al.</i> (2005)
Pure GD	R86X	CGA-TGA	-	Cameron and Sinclair (1997)
Pure GD	N87Y	AAC-TAC	-	Okuhara <i>et al.</i> (2000)
Pure GD	I90M	ATC-ATG	+	Hawkins <i>et al.</i> (1992b)
Pure GD	S91G	AGC-GGC	+	Schmitt-Ney <i>et al.</i> (1995)
Pure GD	L92X	AAG-TAG	-	Muller <i>et al.</i> (1992)
Pure GD	Q93X	CAG-TAG	-	McElreavey <i>et al.</i> (1992b)
Sex reversal	L94P	CTG-CCG	n.a.	Zhi <i>et al.</i> (1996)
Pure GD	G95R	GGA-CGA	-	Hawkins <i>et al.</i> (1992a)
Pure GD	G95Q	GGA-GAA	-	Schaffler <i>et al.</i> (2000)
Pure GD	Q97X	CAG-TAG	+	Bilbao <i>et al.</i> (1996)
Pure GD	L101H	CTT-CAT	-	Braun <i>et al.</i> (1993)
Pure GD	L106I	AAA-ATA	-	Hawkins <i>et al.</i> (1992b)
Pure GD	W107X	TGG-TAG	-	Iida <i>et al.</i> (1994)
Pure GD	P108R	CCA-CGA	-	Jakubiczka <i>et al.</i> (1999)
Pure GD	P108fsX179	1 base deletion A, at nucleotide 324	-	Hawkins <i>et al.</i> (1992b)
Pure GD	F109S	TTC-TCC	+	Jager <i>et al.</i> (1992)
Pure GD	A113T	GCA-ACA	-	Zeng <i>et al.</i> (1993)
Pure GD	E121fsX178	4 base deletion AGAG, at nucleotide 363-366	-	Jager <i>et al.</i> (1990)
Pure GD	P125L	CCG-CTG	+	Schmitt-Ney <i>et al.</i> (1995)

(Continued)

Table 1. (Continued)

Phenotype	Nomenclature	SRY Mutation	Inheritance	Reference
Pure GD	Y127C	TAT-TGT	–	Poulat <i>et al.</i> (1994)
Pure GD	Y127F	TAT-TTT	–	Jordan <i>et al.</i> (2002)
Pure GD	Y127X	TAT-TAA	–	McElreavey <i>et al.</i> (1992a)
Partial GD	Y129N	TAT-AAT	–	Baud <i>et al.</i> (2002)
Pure GD	Y129X	TAT-TAG	–	Giuffre <i>et al.</i> (2004)
Pure GD	Y129X	TAT-TAG	–	Zhou <i>et al.</i> (2005)
Pure GD	P131R	CCT-CGT	–	Lundberg <i>et al.</i> (1998)
Pure GD	R133W	CGG-TGG	–	Affara <i>et al.</i> (1993)
Partial GD	L136S	AAG-AGT	–	Uehara <i>et al.</i> (1999)
Outside HMG box, within bridge region				
Pure GD	S143C	AGT-TGT	–	Shahid <i>et al.</i> (2004)
Outside HMG box and bridge region				
Pure GD	Q158fsX180	1 base deletion A, at nucleotide 473	–	Baldazzi <i>et al.</i> (2003)
Pure GD	L159fsX167	1 base insertion A, at nucleotide 479	–	Shahid <i>et al.</i> (2005)
Pure GD	L163X	TTG-TAG	–	Tajima <i>et al.</i> (1994)

GD – Gonadal Dysplasia.

TH – True Hermaphrodite.

n.a. – Unknown/Not determined.

which is responsible for the DNA-binding and DNA-bending activities of the protein. In addition, a couple of missense mutations outside the HMG domain have recently been identified.

Although most of the mutations described in the *SRY* gene are *de novo*, some cases of fertile fathers and their XY daughters sharing the same altered *SRY* sequence have been reported (Berta *et al.*, 1990; Bilbao *et al.*, 1996; Hawkins *et al.*, 1992b; Jager *et al.*, 1992; Schmitt-Ney *et al.*, 1995). The presence of undetected paternal gonadal mosaicism would provide a possible explanation for this phenomenon.

Some patients with XY pure gonadal dysgenesis may develop gonadal tumors, which are histologically gonadoblastomas and/or dysgerminomas

(Warner *et al.*, 1985). The relationship between XY gonadal dysgenesis and gonadoblastoma, their association with dysgerminoma, and the possibility of a causal relationship with SRY mutations are still unknown.

Only one natural-occurring sequence variant of SRY has been identified: a cysteine-to-thymine nucleotide polymorphism at position 465, altering the codon 155 in the SRY gene. Reported in Japanese and Korean populations, this polymorphism does not cause amino acid change and is not associated with sex reversal (Naito *et al.*, 2001).

Function Consequences of SRY Mutations

Clinical mutations in SRY are powerful tools for studying the mechanism of sex determination in mammals, as they have helped to identify essential functions of SRY. Using a variety of biochemical assays, the SRY protein has been shown to possess sequence-specific DNA-binding activity; and SRY bound to target DNA sequences facilitates DNA bending, allowing recruitment of other factors needed for its activity. Occasionally, these mutations may also alter nuclear localization, depending upon whether the nuclear localization signals contain the mutation.

DNA binding and bending

SRY, which encodes a high mobility group (HMG) box transcription factor, has been shown to bind with a high-affinity specific DNA sequence (A/T AACAA T/A) (Harley *et al.*, 1992). Like other HMG proteins including SOX9 (Mertin *et al.*, 1999), SRY not only binds DNA at a specific sequence, but also bends DNA upon binding (Pontiggia *et al.*, 1994).

A vast majority of human SRY mutations have been localized within the HMG domain of SRY, altering its DNA-binding and/or DNA-bending properties (reviewed in Harley *et al.*, 2003a). Altered *in vitro*, DNA binding and bending of SRY from XY females highlight the importance of these SRY activities during sex determination. These mutations imply an ability to interact with specific DNA sequences and modulate transcription. However, in cases where DNA recognition and bending by SRY is not affected by sex-reversing mutations, it is reasonable to postulate that some other essential function of SRY has been altered.

Nuclear import

Recent advances in the understanding of SRY function have also identified two nuclear localization signals located at each end of the HMG box. Each NLS can independently direct nuclear transport of a carrier protein *in vitro* and *in vivo*, with mutations affecting either the rate and/or the extent of nuclear accumulation. The SRY N-terminal NLS (n-NLS) binds calmodulin (CaM) *in vitro* (Sim *et al.*, 2005), whereas the C-terminal NLS (c-NLS) is recognized by the nuclear import receptor protein importin (IMP) β 1 (Forwood *et al.*, 2001).

Several clinical mutations of SRY have shown altered subcellular localization (Harley *et al.*, 2003a). The failure of SRY to accumulate in the nucleus ultimately alters its function as a transcription factor and its ability to bind or bend DNA.

Furthermore, in certain XY females, SRY mutations within the NLS affect SRY nuclear import by presumably preventing gene activation, either by blocking SRY-IMP β binding (Harley *et al.*, 2003b) or by blocking SRY-CaM binding.

Protein Interaction with KRAB-O

A recently identified mutation in SRY, S143C, was described in a 20-year-old female who, despite presenting with external genitalia and secondary sexual characteristics of normal females, had failed to commence menstruation. Chromosomal analysis revealed a 46,XY karyotype. Cytogenetic and sequence analyses indicated an amino acid substitution within SRY, where a serine residue at codon 143 was substituted with a cysteine residue (Shahid *et al.*, 2004). This mutation lies within the bridge region of SRY, a region which is a putative KRAB-O interactive domain.

KRAB-O

KRAB-O was identified in a yeast two-hybrid screen, using mRNA extracted from murine fetal gonads at 11.5 dpc and Sry as the bait (Oh *et al.*, 2005). Encoded by an alternatively spliced form of KRAB zinc finger protein, ZNF208 (Fig. 3), KRAB-O is a potential interactive protein partner for SRY. Whilst both transcripts are expressed in embryonic gonads, ZNF208

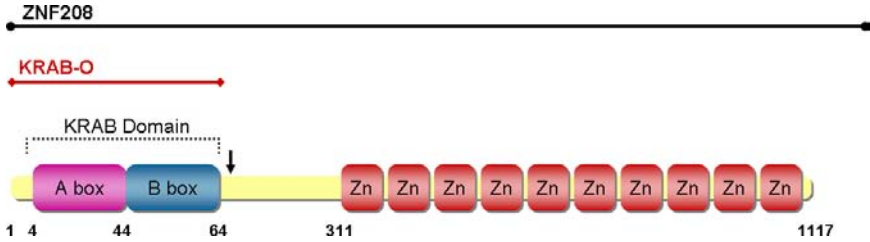

Fig. 3. The SRY-interacting KRAB domain protein is encoded by the ZNF208 locus. The structure of ZNF208 is drawn schematically. The KRAB-O splice variant contains only KRAB-A and KRAB-B domains. The vertical arrow indicates the splice site, giving rise to KRAB-O. Zn, Zinc fingers.

does not interact with SRY under the same experimental conditions used for KRAB-O interaction analysis.

The only published data to date relating to KRAB-O comes from the original study in which it was identified (Oh *et al.*, 2005). In this study, yeast two-hybrid assays and GST-pulldown assays were used to demonstrate the existence of an *in vitro* protein:protein interaction between KRAB-O and murine Sry. Through the assembly of several deletion constructs for different domains of the mouse Sry, the region responsible for this interaction was identified outside the HMG box, between amino acids 92 to 124. Despite minimal conservation between mouse Sry and human SRY in this region, the possibility that this interactive domain is present in human SRY was also explored. The results showed an *in vitro* interaction between human SRY and KRAB-O, localized to amino acids 138 and 155 of human SRY. Oh and colleagues (2005) further indicated that both KRAB-O and mouse Sry colocalized in the nucleus of embryonic gonadal cells at 11.5 dpc using immunohistochemistry.

Despite the identification of the *in vitro* interaction of KRAB-O and SRY, whether KRAB-O is capable of interacting *in vivo* to affect SRY function at the specific time of sex determination is yet to be shown. Also, whether KRAB-O and SRY are able to form a functional complex that specifically targets DNA remains elusive. Furthermore, due to the number of the KRAB zinc finger proteins, the likelihood of functional redundancy raises the possibility that KRAB-O may not be the true SRY-interacting protein within the developing urogenital ridge, but rather the unique function of a yet-to-be identified KRAB protein.

Domain structure

KRAB zinc finger proteins are defined by a conserved N-terminal KRAB domain, a divergent linker region, and a C-terminal domain containing multiple Krüppel (C2H2)-type zinc finger motifs (Urrutia, 2003). The KRAB domain spans approximately 72 amino acids and contains a highly conserved “A box”, which is usually followed by a divergent 32-amino-acid “B box” (Bellefroid *et al.*, 1991). Whilst the KRAB-A domain must be bound (indirectly through a DNA-binding domain) to DNA (Witzgall *et al.*, 1994), Agata *et al.* (1999) predict that both the KRAB-A and KRAB-B boxes fold into a charged amphipathic α helix, which might serve as a protein–protein interaction surface.

Interestingly, many genes encoding KRAB-containing proteins are arranged in clusters in the human genome, with one cluster on chromosome 19 (19q13) and others in centromeric and telomeric regions of other chromosomes; but other genes occur individually throughout the genome (Urrutia, 2003).

Mechanisms of function

All variants of the KRAB domain protein studied to date function to repress transcription by recruiting the transcriptional corepressor KRAB-associated protein 1 (KAP-1) to DNA targets (Friedman *et al.*, 1996). KAP-1 operates as a scaffold protein that recruits heterochromatin protein 1 (HP1), a chromatin organization modifier that serves as a regulator of heterochromatin-mediated gene silencing (Friedman *et al.*, 1996; Kim *et al.*, 1996).

Whilst the biochemical properties of some KRAB zinc finger proteins are characterized, the KRAB-A domain is predicted to represent a widely distributed transcriptional repressor motif (Witzgall *et al.*, 1994), and the natural target genes and/or regulatory pathways in which these proteins might act are yet to be determined (Tanaka *et al.*, 2002).

Model: the role of the SRY–KRAB-O complex in sex determination

On this basis, we propose the following model in which the interaction between KRAB-O and SRY is critical for SRY function during sex determination.

The KRAB domain is an evolutionarily conserved regulatory domain that is a strong DNA-binding–dependent transcription repressor module (Witzgall *et al.*, 1994). Recent experiments involving the KRAB-A domains of ZNF224, ZNF267, ZNF328, ZNF383, ZNF411, ZNF446, and ZNF649 — fused to the GAL4 DNA-binding domain — have all shown transcriptional repressor activity (Cao *et al.*, 2005; Liu *et al.*, 2005; Liu *et al.*, 2004; Medugno *et al.*, 2005; Ou *et al.*, 2005; Schnabl *et al.*, 2005; Witzgall *et al.*, 1994; Yang *et al.*, 2005). However, the mechanisms responsible for sequence-specific targeting of this repression are unclear. Whilst KAP-1 is ubiquitously expressed and is the universal corepressor for the KRAB domain, KAP-1 is also associated with both the euchromatic and heterochromatic regions (Ryan *et al.*, 1999).

The model shown in Fig. 4 proposes that a KRAB-zinc finger protein recruits the KAP-1 corepressor to DNA; this complex in turn binds to HP1 and forms a complex. This KRAB-O repression complex may then nucleate local heterochromatin formation, resulting in gene silencing of a repressor of a male sex-determining gene, Q, ultimately leading to Q activation. Accordingly, target genes of the SRY–KRAB-O repression complex could be either activators of ovarian differentiation and/or repressors of testis differentiation, since ovarian differentiation is the default sexual

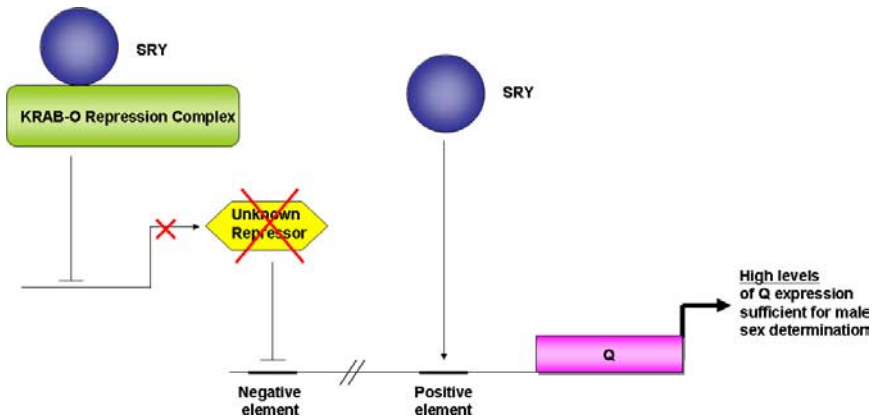

Fig. 4. Dose-dependent, dual-transcriptional function of SRY. An SRY–KRAB-O complex binds and transcriptionally silences a promoter of either activators of ovarian differentiation and/or repressors of testis differentiation, leading to the upregulation of Q, a male sex-determining gene. In addition, independent of KRAB-O, SRY is able to activate Q in a dose-dependent manner.

developmental pathway. The identity of the repressor gene remains elusive, but DAX-1 has been proposed as the repressor (Swain *et al.*, 1998).

The endpoint for the SRY–KRAB–O function would be the upregulation of Q. The SRY–KRAB–O complex would bind to the promoter region of a repressor, which binds to the Q promoter (Fig. 4). Our model is consistent with SOX9 being a direct downstream target of SRY, and provides genetic evidence for a general repressor model of sex determination in mammals (Graves, 1998; McElreavey *et al.*, 1993).

Nevertheless, whilst the majority of KRAB domains have been implicated in repression complexes, overexpression of ZNF480 — which is only expressed in embryonic heart — activates the transcriptional activities of AP-1 and SRE (Yi *et al.*, 2004). This data suggest that the KRAB domain of ZNF480 may act as a positive regulator in MAPK-mediated signaling pathways that leads to the activation of AP-1 and SRE, which are the targets of ERK, JNK, and p38 (reviewed by Buchwalter *et al.*, 2004).

In support of an activation model resulting from an SRY and KRAB–O complex, recent studies suggest that HP1 may be associated with some actively transcribed genes and may be required for the expression of certain genes (De Lucia *et al.*, 2005; Piacentini *et al.*, 2003). Thus, the possibility that a KRAB protein may function with SRY as a component of a gene-activation complex cannot be ruled out at the present time.

Conclusions

SRY mutations have provided some insight into *in vitro* function; however, target genes of SRY remain to be identified, thus limiting the scope of the *in vitro* studies. SRY and most other sex-determining genes are transcription factors whose targets are unknown. Future experiments directed at identifying the targets of SRY, SOX9, SF-1, and DAX-1 are likely to reveal new genes in the network of gene interactions required to make a testis — genes which, when mutated, could explain intersex disorders.

Acknowledgments

The authors wish to thank Stefan Bagheri-Fam for critical reading of the manuscript. This work is supported by the NHMRC Program Grant no. 334314.

References

- Achermann, J. C., Ito, M., Hindmarsh, P. C., and Jameson, J. L. (1999). A mutation in the gene encoding steroidogenic factor-1 causes XY sex reversal and adrenal failure in humans. *Nat Genet* **22**, 125–126.
- Affara, N. A., Chalmers, I. J., and Ferguson-Smith, M. A. (1993). Analysis of the SRY gene in 22 sex-reversed XY females identifies four new point mutations in the conserved DNA binding domain. *Hum Mol Genet* **2**, 785–789.
- Agata, Y., Matsuda, E., and Shimizu, A. (1999). Two novel Kruppel-associated box-containing zinc-finger proteins, KRAZ1 and KRAZ2, repress transcription through functional interaction with the corepressor KAP-1. *J Biol Chem* **274**, 16412–16422.
- Aleck, K. A., Argueso, L., Stone, J., Hackel, J. G., and Erickson, R. P. (1999). True hermaphroditism with partial duplication of chromosome 22 and without SRY. *Am J Med Genet* **85**, 2–4.
- Assumpcao, J. G., Benedetti, C. E., Maciel-Guerra, A. T., Guerra, G., Jr., Baptista, M. T., Scolfaro, M. R., and de Mello, M. P. (2002). Novel mutations affecting SRY DNA-binding activity: the HMG box N65H associated with 46,XY pure gonadal dysgenesis and the familial non-HMG box R30I associated with variable phenotypes. *J Mol Med* **80**, 782–790.
- Baldazzi, L., Nicoletti, A., Gennari, M., Barbaro, M., Pirazzoli, P., Cicognani, A., and Cacciari, E. (2003). Two new point mutations of the SRY gene identified in two Italian 46,XY females with gonadal dysgenesis. *Clin Genet* **64**, 258–260.
- Bardoni, B., Zanaria, E., Guioli, S., Florida, G., Worley, K. C., Tonini, G., Ferrante, E., Chiumello, G., McCabe, E. R., Fraccaro, M., et al. (1994). A dosage sensitive locus at chromosome Xp21 is involved in male to female sex reversal. *Nat Genet* **7**, 497–501.
- Batanian, J. R., Grange, D. K., Fleming, R., Gadre, B., and Wetzel, J. (2001). Two unbalanced translocations involving a common 6p25 region in two XY female patients. *Clin Genet* **59**, 52–57.
- Battiloro, E., Angeletti, B., Tozzi, M. C., Bruni, L., Tondini, S., Vignetti, P., Verna, R., and D'Ambrosio, E. (1997). A novel double nucleotide substitution in the HMG box of the SRY gene associated with Swyer syndrome. *Hum Genet* **100**, 585–587.
- Baud, S., Margeat, E., Lumbroso, S., Paris, F., Sultan, C., Royer, C., and Pujol, N. (2002). Equilibrium binding assays reveal the elevated stoichiometry and salt dependence of the interaction between full-length human sex-determining region on the Y chromosome (SRY) and DNA. *J Biol Chem* **277**, 18404–18410.
- Bellefroid, E. J., Poncet, D. A., Lecocq, P. J., Relevant, O., and Martial, J. A. (1991). The evolutionarily conserved Kruppel-associated box domain defines a subfamily of eukaryotic multifingered proteins. *Proc Natl Acad Sci U S A* **88**, 3608–3612.
- Berta, P., Hawkins, J. R., Sinclair, A. H., Taylor, A., Griffiths, B. L., Goodfellow, P. N., and Fellous, M. (1990). Genetic evidence equating SRY and the testis-determining factor. *Nature* **348**, 448–450.
- Bianchi, M. E., Beltrame, M., and Paonessa, G. (1989). Specific recognition of cruciform DNA by nuclear protein HMG1. *Science* **243**, 1056–1059.
- Biason-Lauber, A., Konrad, D., Navratil, F., and Schoenle, E. J. (2004). A WNT4 mutation associated with Mullerian-duct regression and virilization in a 46,XX woman. *N Engl J Med* **351**, 792–798.

- Biason-Lauber, A., and Schoenle, E. J. (2000). Apparently normal ovarian differentiation in a prepubertal girl with transcriptionally inactive steroidogenic factor 1 (NR5A1/SF-1) and adrenocortical insufficiency. *Am J Hum Genet* **67**, 1563–1568.
- Billbao, J. R., Loridan, L., and Castano, L. (1996). A novel postzygotic nonsense mutation in SRY in familial XY gonadal dysgenesis. *Hum Genet* **97**, 537–539.
- Braun, A., Kammerer, S., Cleve, H., Lohrs, U., Schwarz, H. P., and Kuhnle, U. (1993). True hermaphroditism in a 46,XY individual, caused by a postzygotic somatic point mutation in the male gonadal sex-determining locus (SRY): molecular genetics and histological findings in a sporadic case. *Am J Hum Genet* **52**, 578–585.
- Brown, S., Yu, C., Lanzano, P., Heller, D., Thomas, L., Warburton, D., Kitajewski, J., and Stadtmauer, L. (1998). A de novo mutation (Gln2Stop) at the 5' end of the SRY gene leads to sex reversal with partial ovarian function. *Am J Hum Genet* **62**, 189–192.
- Buchwalter, G., Gross, C., and Wasyluk, B. (2004). Ets ternary complex transcription factors. *Gene* **324**, 1–14.
- Bullejos, M., Bowles, J., and Koopman, P. (2001). Searching for missing pieces of the sex-determination puzzle. *J Exp Zool* **290**, 517–522.
- Call, K. M., Glaser, T., Ito, C. Y., Buckler, A. J., Pelletier, J., Haber, D. A., Rose, E. A., Kral, A., Yeger, H., Lewis, W. H., *et al.* (1990). Isolation and characterization of a zinc finger polypeptide gene at the human chromosome 11 Wilms' tumor locus. *Cell* **60**, 509–520.
- Cameron, F. J., and Sinclair, A. H. (1997). Mutation in SRY and SOX9: testis-determining genes. *Hum Mutat* **9**, 388–395.
- Cao, L., Wang, Z., Zhu, C., Zhao, Y., Yuan, W., Li, J., Wang, Y., Ying, Z., Li, Y., Yu, W., *et al.* (2005). ZNF383, a novel KRAB-containing zinc finger protein, suppresses MAPK signaling pathway. *Biochem Biophys Res Commun* **333**, 1050–1059.
- Capel, B. (2000). The battle of the sexes. *Mech Dev* **92**, 89–103.
- Cousineau, A. J., Higgins, J. V., Hackel, E., Waterman, D. F., Toriello, H., Carlile, P. A., and Cook, P. J. (1981). Cytogenetic recognition of chromosomal duplication [dup(1)(p31.4 leads to p22.1)] and the detection of three different alleles at the PGM1 locus. *Ann Hum Genet* **45**, 337–340.
- De Lucia, F., Ni, J. Q., Vaillant, C., and Sun, F. L. (2005). HP1 modulates the transcription of cell-cycle regulators in *Drosophila melanogaster*. *Nucleic Acids Res* **33**, 2852–2858.
- De Santa Barbara, P., Bonneaud, N., Boizet, B., Desclozeaux, M., Moniot, B., Sudbeck, P., Scherer, G., Poulat, F., and Berta, P. (1998). Direct interaction of SRY-related protein SOX9 and steroidogenic factor 1 regulates transcription of the human anti-Mullerian hormone gene. *Mol Cell Biol* **18**, 6653–6665.
- Desclozeaux, M., Poulat, F., de Santa Barbara, P., Capony, J. P., Turowski, P., Jay, P., Mejean, C., Moniot, B., Boizet, B., and Berta, P. (1998). Phosphorylation of an N-terminal motif enhances DNA-binding activity of the human SRY protein. *J Biol Chem* **273**, 7988–7995.
- Domenice, S., Yumie Nishi, M., Correia Billerbeck, A. E., Latronico, A. C., Aparecida Medeiros, M., Russell, A. J., Vass, K., Marino Carvalho, F., Costa Frade, E. M., Prado Arnhold, I. J., and Bilharinho Mendonca, B. (1998). A novel missense mutation (S18N) in the 5' non-HMG box region of the SRY gene in a patient with partial gonadal dysgenesis and his normal male relatives. *Hum Genet* **102**, 213–215.
- Elejalde, B. R., Opitz, J. M., de Elejalde, M. M., Gilbert, E. F., Abellera, M., Meisner, L., Lebel, R. R., and Hartigan, J. M. (1984). Tandem dup (1p) within the short arm of

- chromosome 1 in a child with ambiguous genitalia and multiple congenital anomalies. *Am J Med Genet* **17**, 723–730.
- Fernandez, R., Marchal, J. A., Sanchez, A., and Pasaro, E. (2002). A point mutation, R59G, within the HMG-SRY box in a female 45,X/46,X,psu dic(Y)(pter→q11::q11→pter). *Hum Genet* **111**, 242–246.
- Ferrari, S., Harley, V. R., Pontiggia, A., Goodfellow, P. N., Lovell-Badge, R., and Bianchi, M. E. (1992). SRY, like HMG1, recognizes sharp angles in DNA. *EMBO J* **11**, 4497–4506.
- Forwood, J. K., Harley, V., and Jans, D. A. (2001). The C-terminal nuclear localization signal of the sex-determining region Y (SRY) high mobility group domain mediates nuclear import through importin beta 1. *J Biol Chem* **276**, 46575–46582.
- Foster, J. W., Dominguez-Steglich, M. A., Guioli, S., Kowk, G., Weller, P. A., Stevanovic, M., Weissenbach, J., Mansour, S., Young, I. D., Goodfellow, P. N., et al. (1994). Campomelic dysplasia and autosomal sex reversal caused by mutations in an SRY-related gene. *Nature* **372**, 525–530.
- Friedman, J. R., Fredericks, W. J., Jensen, D. E., Speicher, D. W., Huang, X. P., Neilson, E. G., and Rauscher, F. J. (1996). KAP-1, a novel corepressor for the highly conserved KRAB repression domain. *Genes Dev* **10**, 2067–2078.
- Gessler, M., Poustka, A., Cavenee, W., Neve, R. L., Orkin, S. H., and Bruns, G. A. (1990). Homozygous deletion in Wilms tumours of a zinc-finger gene identified by chromosome jumping. *Nature* **343**, 774–778.
- Giese, K., Cox, J., and Grosschedl, R. (1992). The HMG domain of lymphoid enhancer factor 1 bends DNA and facilitates assembly of functional nucleoprotein structures. *Cell* **69**, 185–195.
- Giuffrè, M., Sammarco, P., Fabiano, C., Giardina, F., Lunetta, F., and Corsello, G. (2004). Identification of a new nonsense mutation (Tyr129Stop) of the SRY gene in a newborn infant with XY sex-reversal. *Am J Med Genet A* **128**, 46–47.
- Graves, J. A. (1998). Interactions between SRY and SOX genes in mammalian sex determination. *Bioessays* **20**, 264–269.
- Gubbay, J., Collignon, J., Koopman, P., Capel, B., Economou, A., Munsterberg, A., Vivian, N., Goodfellow, P., and Lovell-Badge, R. (1990). A gene mapping to the sex-determining region of the mouse Y chromosome is a member of a novel family of embryonically expressed genes. *Nature* **346**, 245–250.
- Hacker, A., Capel, B., Goodfellow, P., and Lovell-Badge, R. (1995). Expression of Sry, the mouse sex determining gene. *Development* **121**, 1603–1614.
- Hanley, N. A., Hagan, D. M., Clement-Jones, M., Ball, S. G., Strachan, T., Salas-Cortés, L., McElreavey, K., Lindsay, S., Robson, S., Bullen, P., et al. (2000). SRY, SOX9 and DAX1 expression patterns during human sex determination and gonadal development. *Mech Dev* **91**, 403–407.
- Harley, V. R., Clarkson, M. J., and Argentaro, A. (2003a). The molecular action and regulation of the testis-determining factors, SRY (sex-determining region on the Y chromosome) and SOX9 [SRY-related high-mobility group (HMG) box 9]. *Endocr Rev* **24**, 466–487.
- Harley, V. R., Jackson, D. I., Hextall, P. J., Hawkins, J. R., Berkovitz, G. D., Sockanathan, S., Lovell-Badge, R., and Goodfellow, P. N. (1992). DNA binding activity of recombinant SRY from normal males and XY females. *Science* **255**, 453–456.

- Harley, V. R., Layfield, S., Mitchell, C. L., Forwood, J. K., John, A. P., Briggs, L. J., McDowall, S. G., and Jans, D. A. (2003b). Defective importin beta recognition and nuclear import of the sex-determining factor SRY are associated with XY sex-reversing mutations. *Proc Natl Acad Sci U S A* **100**, 7045–7050.
- Harley, V. R., Lovell-Badge, R., and Goodfellow, P. N. (1994). Definition of a consensus DNA binding site for SRY. *Nucleic Acids Res* **22**, 1500–1501.
- Hawkins, J. R., Taylor, A., Berta, P., Levilliers, J., Van der Auwera, B., and Goodfellow, P. N. (1992a). Mutational analysis of SRY: nonsense and missense mutations in XY sex reversal. *Hum Genet* **88**, 471–474.
- Hawkins, J. R., Taylor, A., Goodfellow, P. N., Migeon, C. J., Smith, K. D., and Berkovitz, G. D. (1992b). Evidence for increased prevalence of SRY mutations in XY females with complete rather than partial gonadal dysgenesis. *Am J Hum Genet* **51**, 979–984.
- Herzer, U., Crocoll, A., Barton, D., Howells, N., and Englert, C. (1999). The Wilms tumor suppressor gene *w1* is required for development of the spleen. *Curr Biol* **9**, 837–840.
- Hines, R. S., Tho, S. P., Zhang, Y. Y., Plouffe, L., Jr., Hansen, K. A., Khan, I., and McDonough, P. G. (1997). Paternal somatic and germ-line mosaicism for a sex-determining region on Y (SRY) missense mutation leading to recurrent 46,XY sex reversal. *Fertil Steril* **67**, 675–679.
- Hiort, O., Gramss, B., and Klauber, G. T. (1995). True hermaphroditism with 46,XY karyotype and a point mutation in the SRY gene. *J Pediatr* **126**, 1022.
- Huang, B., Wang, S., Ning, Y., Lamb, A. N., and Bartley, J. (1999). Autosomal XX sex reversal caused by duplication of SOX9. *Am J Med Genet* **87**, 349–353.
- Iida, T., Nakahori, Y., Komaki, R., Mori, E., Hayashi, N., Tsutsumi, O., Taketani, Y., and Nakagome, Y. (1994). A novel nonsense mutation in the HMG box of the SRY gene in a patient with XY sex reversal. *Hum Mol Genet* **3**, 1437–1438.
- Imai, A., Takagi, A., and Tamaya, T. (1999). A novel sex-determining region on Y (SRY) missense mutation identified in a 46,XY female and also in the father. *Endocr J* **46**, 735–739.
- Ingham, P. W. (1998). Transducing hedgehog: the story so far. *EMBO J* **17**, 3505–3511.
- Jager, R. J., Anvret, M., Hall, K., and Scherer, G. (1990). A human XY female with a frame shift mutation in the candidate testis-determining gene SRY. *Nature* **348**, 452–454.
- Jager, R. J., Harley, V. R., Pfeiffer, R. A., Goodfellow, P. N., and Scherer, G. (1992). A familial mutation in the testis-determining gene SRY shared by both sexes. *Hum Genet* **90**, 350–355.
- Jakubiczka, S., Bettecken, T., Stumm, M., Neulen, J., and Wieacker, P. (1999). Another mutation within the HMG-box of the SRY gene associated with Swyer syndrome. *Hum Mutat* **13**, 85.
- Jeays-Ward, K., Hoyle, C., Brennan, J., Dandonneau, M., Allodus, G., Capel, B., and Swain, A. (2003). Endothelial and steroidogenic cell migration are regulated by WNT4 in the developing mammalian gonad. *Development* **130**, 3663–3670.
- Jordan, B. K., Jain, M., Natarajan, S., Frasier, S. D., and Vilain, E. (2002). Familial mutation in the testis-determining gene SRY shared by an XY female and her normal father. *J Clin Endocrinol Metab* **87**, 3428–3432.
- Jordan, B. K., Shen, J. H., Olosa, R., Ingraham, H. A., and Vilain, E. (2003). Wnt4 over-expression disrupts normal testicular vasculature and inhibits testosterone synthesis by

- repressing steroidogenic factor 1/beta-catenin synergy. *Proc Natl Acad Sci U S A* **100**, 10866–10871.
- Kellermayer, R., Halvax, L., Czako, M., Shahid, M., Dhillon, V. S., Husain, S. A., Sule, N., Gomori, E., Mammel, M., and Kosztolanyi, G. (2005). A novel frame shift mutation in the HMG box of the SRY gene in a patient with complete 46,XY pure gonadal dysgenesis. *Diagn Mol Pathol* **14**, 159–163.
- Kim, S. S., Chen, Y. M., O'Leary, E., Witzgall, R., Vidal, M., and Bonventre, J. V. (1996). A novel member of the RING finger family, KRIP-1, associates with the KRAB-A transcriptional repressor domain of zinc finger proteins. *Proc Natl Acad Sci U S A* **93**, 15299–15304.
- Kreidberg, J. A., Sariola, H., Loring, J. M., Maeda, M., Pelletier, J., Housman, D., and Jaenisch, R. (1993). WT-1 is required for early kidney development. *Cell* **74**, 679–691.
- Liu, F., Zhu, C., Xiao, J., Wang, Y., Tang, W., Yuan, W., Zhao, Y., Li, Y., Xiang, Z., Wu, X., and Liu, M. (2005). A novel human KRAB-containing zinc-finger gene ZNF446 inhibits transcriptional activities of SRE and AP-1. *Biochem Biophys Res Commun* **333**, 5–13.
- Liu, H., Zhu, C., Luo, J., Wang, Y., Li, D., Li, Y., Zhou, J., Yuan, W., Ou, Y., Liu, M., and Wu, X. (2004). ZNF411, a novel KRAB-containing zinc-finger protein, suppresses MAP kinase signaling pathway. *Biochem Biophys Res Commun* **320**, 45–53.
- Lovell-Badge, R. (1992). Testis determination: soft talk and kinky sex. *Curr Opin Genet Dev* **2**, 596–601.
- Lundberg, Y., Ritzen, M., Harlin, J., and Wedell, A. (1998). Novel missense mutation (P131R) in the HMG box of SRY in XY sex reversal. *Hum Mutat* (Suppl 1), S328.
- Luo, X., Ikeda, Y., and Parker, K. L. (1994). A cell-specific nuclear receptor is essential for adrenal and gonadal development and sexual differentiation. *Cell* **77**, 481–490.
- Matsuzawa-Watanabe, Y., Inoue, J., and Semba, K. (2003). Transcriptional activity of testis-determining factor SRY is modulated by the Wilms' tumor 1 gene product, WT1. *Oncogene* **22**, 7900–7904.
- Mayer, A., Mosler, G., Just, W., Pilgrim, C., and Reisert, I. (2000). Developmental profile of Sry transcripts in mouse brain. *Neurogenetics* **3**, 25–30.
- McElreavey, K., Vilain, E., Abbas, N., Costa, J. M., Souleyreau, N., Kucheria, K., Boucekkine, C., Thibaud, E., Brauner, R., Flamant, F., et al. (1992a). XY sex reversal associated with a deletion 5' to the SRY 'HMG box' in the testis-determining region. *Proc Natl Acad Sci U S A* **89**, 11016–11020.
- McElreavey, K., Vilain, E., Abbas, N., Herskowitz, I., and Fellous, M. (1993). A regulatory cascade hypothesis for mammalian sex determination: SRY represses a negative regulator of male development. *Proc Natl Acad Sci U S A* **90**, 3368–3372.
- McElreavey, K. D., Vilain, E., Boucekkine, C., Vidaud, M., Jaubert, F., Richaud, F., and Fellous, M. (1992b). XY sex reversal associated with a nonsense mutation in SRY. *Genomics* **13**, 838–840.
- Medugno, L., Florio, F., De Cegli, R., Grosso, M., Lupo, A., Costanzo, P., and Izzo, P. (2005). The Kruppel-like zinc-finger protein ZNF224 represses aldolase A gene transcription by interacting with the KAP-1 co-repressor protein. *Gene* **359**, 35–43.
- Mertin, S., McDowall, S. G., and Harley, V. R. (1999). The DNA-binding specificity of SOX9 and other SOX proteins. *Nucleic Acids Res* **27**, 1359–1364.
- Milsted, A., Serova, L., Sabban, E. L., Dunphy, G., Turner, M. E., and Ely, D. L. (2004). Regulation of tyrosine hydroxylase gene transcription by Sry. *Neurosci Lett* **369**, 203–207.

- Mohammed, F. M., Farag, T. I., Gunawardana, S. S., al-Digashim, D. D., al-Awadi, S. A., al-Othman, S. A., and Sundareshan, T. S. (1989). Direct duplication of chromosome 1, dir dup(1)(p21.2–p32) in a Bedouin boy with multiple congenital anomalies. *Am J Med Genet* **32**, 353–355.
- Moore, A. W., McInnes, L., Kreidberg, J., Hastie, N. D., and Schedl, A. (1999). YAC complementation shows a requirement for Wt1 in the development of epicardium, adrenal gland and throughout nephrogenesis. *Development* **126**, 1845–1857.
- Muller, J., Schwartz, M., and Skakkebaek, N. E. (1992). Analysis of the sex-determining region of the Y chromosome (SRY) in sex reversed patients: point-mutation in SRY causing sex-reversion in a 46,XY female. *J Clin Endocrinol Metab* **75**, 331–333.
- Naito, E., Umetsu, K., Yuasa, I., Dewa, K., Sumi, H., and Yamanouchi, H. (2001). A novel dimorphism in the human SRY gene: usefulness in human migration studies. *Int J Legal Med* **114**, 274–277.
- Oh, H. J., Li, Y., and Lau, Y.-F. C. (2005). SRY associates with the heterochromatin protein 1 complex by interacting with a KRAB domain protein. *Biol Reprod* **72**, 407–415.
- Ohe, K., Lalli, E., and Sassone-Corsi, P. (2002). A direct role of SRY and SOX proteins in pre-mRNA splicing. *Proc Natl Acad Sci U S A* **99**, 1146–1151.
- Okuhara, K., Tajima, T., Nakae, J., and Fujieda, K. (2000). A novel missense mutation in the HMG box region of the SRY gene in a Japanese patient with an XY sex reversal. *J Hum Genet* **45**, 112–114.
- Ou, Y., Wang, S., Cai, Z., Wang, Y., Wang, C., Li, Y., Li, F., Yuan, W., Liu, B., Wu, X., and Liu, M. (2005). ZNF328, a novel human zinc-finger protein, suppresses transcriptional activities of SRE and AP-1. *Biochem Biophys Res Commun* **333**, 1034–1044.
- Peters, R., King, C. Y., Ukiyama, E., Falsafi, S., Donahoe, P. K., and Weiss, M. A. (1995). An SRY mutation causing sex reversal resolves a general mechanism of structure-specific DNA recognition: application to the four-way DNA junction. *Biochemistry* **34**, 4569–4576.
- Piacentini, L., Fanti, L., Berloco, M., Perrini, B., and Pimpinelli, S. (2003). Heterochromatin protein 1 (HP1) is associated with induced gene expression in *Drosophila* euchromatin. *J Cell Biol* **161**, 707–714.
- Pontiggia, A., Rimini, R., Harley, V. R., Goodfellow, P. N., Lovell-Badge, R., and Bianchi, M. E. (1994). Sex-reversing mutations affect the architecture of SRY-DNA complexes. *EMBO J* **13**, 6115–6124.
- Poulat, F., Barbara, P. S., Desclozeaux, M., Soullier, S., Moniot, B., Bonneaud, N., and Boizet, B. (1997). The human testis determining factor SRY binds a nuclear factor containing PDZ protein interaction domain. *J Biol Chem* **272**, 7167–7172.
- Poulat, F., Soullier, S., Goze, C., Heitz, F., Calas, B., and Berta, P. (1994). Description and functional implications of a novel mutation in the sex-determining gene SRY. *Hum Mutat* **3**, 200–204.
- Qin, Y., and Bishop, C. E. (2005). Sox9 is sufficient for functional testis development producing fertile male mice in the absence of Sry. *Hum Mol Genet* **14**, 1221–1229.
- Ryan, R. F., Schultz, D. C., Ayyanathan, K., Singh, P. B., Friedman, J. R., Fredericks, W. J., and Rauscher, F. J., 3rd (1999). KAP-1 corepressor protein interacts and colocalizes with heterochromatic and euchromatic HP1 proteins: a potential role for Kruppel-associated box-zinc finger proteins in heterochromatin-mediated gene silencing. *Mol Cell Biol* **19**, 4366–4378.

- Schaffler, A., Barth, N., Winkler, K., Zietz, B., Rummele, P., Knuchel, R., Scholmerich, J., and Palitzsch, K. D. (2000). Identification of a new missense mutation (Gly95Glu) in a highly conserved codon within the high-mobility group box of the sex-determining region Y gene: report on a 46,XY female with gonadal dysgenesis and yolk-sac tumor. *J Clin Endocrinol Metab* **85**, 2287–2292.
- Scharnhorst, V., van der Eb, A. J., and Jochemsen, A. G. (2001). WT1 proteins: functions in growth and differentiation. *Gene* **273**, 141–161.
- Scherer, G., Held, M., Erdel, M., Meschede, D., Horst, J., Lesniewicz, R., and Midro, A. T. (1998). Three novel SRY mutations in XY gonadal dysgenesis and the enigma of XY gonadal dysgenesis cases without SRY mutations. *Cytogenet Cell Genet* **80**, 188–192.
- Schmitt-Ney, M., Thiele, H., Kaltwasser, P., Bardoni, B., Cisternino, M., and Scherer, G. (1995). Two novel SRY missense mutations reducing DNA binding identified in XY females and their mosaic fathers. *Am J Hum Genet* **56**, 862–869.
- Schnabl, B., Hu, K., Muhlbauer, M., Hellerbrand, C., Stefanovic, B., Brenner, D. A., and Scholmerich, J. (2005). Zinc finger protein 267 is up-regulated during the activation process of human hepatic stellate cells and functions as a negative transcriptional regulator of MMP-10. *Biochem Biophys Res Commun* **335**, 87–96.
- Shahid, M., Dhillon, V. S., Aslam, M., and Husain, S. A. (2005). Three new novel point mutations localized within and downstream of high-mobility group-box region in SRY gene in three Indian females with Turner syndrome. *J Clin Endocrinol Metab* **90**, 2429–2435.
- Shahid, M., Dhillon, V. S., Jain, N., Hedau, S., Diwakar, S., Sachdeva, P., Batra, S., Das, B. C., and Husain, S. A. (2004). Two new novel point mutations localized upstream and downstream of the HMG box region of the SRY gene in three Indian 46,XY females with sex reversal and gonadal tumour formation. *Mol Hum Reprod* **10**, 521–526.
- Sim, H., Rimmer, K., Kelly, S., Ludbrook, L. M., Clayton, A. H., and Harley, V. R. (2005). Defective calmodulin-mediated nuclear transport of the sex-determining region of the Y chromosome (SRY) in XY sex reversal. *Mol Endocrinol* **19**, 1884–1892.
- Sinclair, A. H., Berta, P., Palmer, M. S., Hawkins, J. R., Griffiths, B. L., Smith, M. J., Foster, J. W., Frischauf, A. M., Lovell-Badge, R., and Goodfellow, P. N. (1990). A gene from the human sex-determining region encodes a protein with homology to a conserved DNA-binding motif. *Nature* **346**, 240–244.
- Slavotinek, A., Schwarz, C., Getty, J. F., Stecko, O., Goodman, F., and Kingston, H. (1999). Two cases with interstitial deletions of chromosome 2 and sex reversal in one. *Am J Med Genet* **86**, 75–81.
- Swain, A., Narvaez, V., Burgoyne, P., Camerino, G., and Lovell-Badge, R. (1998). Dax1 antagonizes Sry action in mammalian sex determination. *Nature* **391**, 761–767.
- Tajima, T., Nakae, J., Shinohara, N., and Fujieda, K. (1994). A novel mutation localized in the 3' non-HMG box region of the SRY gene in 46,XY gonadal dysgenesis. *Hum Mol Genet* **3**, 1187–1189.
- Takagi, A., Imai, A., and Tamaya, T. (1999). A novel sex-determining region on Y (SRY) nonsense mutation identified in a 45,X/47,XYY female. *Fertil Steril* **72**, 167–169.
- Tanaka, K., Tsumaki, N., Kozak, C. A., Matsumoto, Y., Nakatani, F., Iwamoto, Y., and Yamada, Y. (2002). A Kruppel-associated box-zinc finger protein, NT2, represses cell-type-specific promoter activity of the alpha 2(XI) collagen gene. *Mol Cell Biol* **22**, 4256–4267.

- Uehara, S., Funato, T., Yaegashi, N., Suzuki, H., Sato, J., Sasaki, T., and Yajima, A. (1999). SRY mutation and tumor formation on the gonads of XP pure gonadal dysgenesis patients. *Cancer Genet Cytogenet* **113**, 78–84.
- Umehara, F., Tate, G., Itoh, K., Yamaguchi, N., Douchi, T., Mitsuya, T., and Osame, M. (2000). A novel mutation of desert hedgehog in a patient with 46,XY partial gonadal dysgenesis accompanied by minifascicular neuropathy. *Am J Hum Genet* **67**, 1302–1305.
- Urrutia, R. (2003). KRAB-containing zinc-finger repressor proteins. *Genome Biol* **4**, 231.
- Vainio, S., Heikkila, M., Kispert, A., Chin, N., and McMahon, A. P. (1999). Female development in mammals is regulated by Wnt-4 signalling. *Nature* **397**, 405–409.
- Veitia, R., Ion, A., Barbaux, S., Jobling, M. A., Souleyreau, N., Ennis, K., Ostrer, H., Tosi, M., Meo, T., Chibani, J., *et al.* (1997). Mutations and sequence variants in the testis-determining region of the Y chromosome in individuals with a 46,XY female phenotype. *Hum Genet* **99**, 648–652.
- Wagner, T., Wirth, J., Meyer, J., Zabel, B., Held, M., Zimmer, J., Pasantes, J., Bricarelli, F. D., Keutel, J., Hustert, E., *et al.* (1994). Autosomal sex reversal and campomelic dysplasia are caused by mutations in and around the SRY-related gene SOX9. *Cell* **79**, 1111–1120.
- Warner, B. A., Monsaert, R. P., Stumpf, P. G., Kulin, H. E., and Wachtel, S. S. (1985). 46,XY gonadal dysgenesis: is oncogenesis related to H-Y phenotype or breast development? *Hum Genet* **69**, 79–85.
- Whitfield, L. S., Lovell-Badge, R., and Goodfellow, P. N. (1993). Rapid sequence evolution of the mammalian sex-determining gene SRY. *Nature* **364**, 713–715.
- Wilkie, A. O., Campbell, F. M., Daubeney, P., Grant, D. B., Daniels, R. J., Mullarkey, M., Affara, N. A., Fitchett, M., and Huson, S. M. (1993). Complete and partial XY sex reversal associated with terminal deletion of 10q: report of 2 cases and literature review. *Am J Med Genet* **46**, 597–600.
- Witzgall, R., O'Leary, E., Leaf, A., Onaldi, D., and Bonventre, J. V. (1994). The Kruppel-associated box-A (KRAB-A) domain of zinc finger proteins mediates transcriptional repression. *Proc Natl Acad Sci U S A* **91**, 4514–4518.
- Yang, H., Yuan, W., Wang, Y., Zhu, C., Liu, B., Yang, D., Li, Y., Wang, C., Wu, X., and Liu, M. (2005). ZNF649, a novel Kruppel type zinc-finger protein, functions as a transcriptional suppressor. *Biochem Biophys Res Commun* **333**, 206–215.
- Yao, H. H., Whoriskey, W., and Capel, B. (2002). Desert Hedgehog/Patched 1 signaling specifies fetal Leydig cell fate in testis organogenesis. *Genes Dev* **16**, 1433–1440.
- Yi, Z., Li, Y., Ma, W., Li, D., Zhu, C., Luo, J., Wang, Y., Huang, X., Yuan, W., Liu, M., and Wu, X. (2004). A novel KRAB zinc-finger protein, ZNF480, expresses in human heart and activates transcriptional activities of AP-1 and SRE. *Biochem Biophys Res Commun* **320**, 409–415.
- Yu, R. N., Ito, M., and Jameson, J. L. (1998). The murine Dax-1 promoter is stimulated by SF-1 (steroidogenic factor-1) and inhibited by COUP-TF (chicken ovalbumin upstream promoter-transcription factor) via a composite nuclear receptor-regulatory element. *Mol Endocrinol* **12**, 1010–1022.
- Zanaria, E., Muscatelli, F., Bardoni, B., Strom, T. M., Guioli, S., Guo, W., Lalli, E., Moser, C., Walker, A. P., McCabe, E. R., *et al.* (1994). An unusual member of the nuclear

- hormone receptor superfamily responsible for X-linked adrenal hypoplasia congenita. *Nature* **372**, 635–641.
- Zeng, Y. T., Ren, Z. R., Zhang, M. L., Huang, Y., Zeng, F. Y., and Huang, S. Z. (1993). A new de novo mutation (A113T) in HMG box of the SRY gene leads to XY gonadal dysgenesis. *J Med Genet* **30**, 655–657.
- Zenteno, J. C., Carranza-Lira, S., Jimenez, A. L., and Kofman, S. (2003). A de novo phe671eu mutation in the SRY gene in a patient with complete 46,XY gonadal dysgenesis. *J Endocrinol Invest* **26**, 1117–1119.
- Zhi, L., Zheng-Gang, X., and Guanghui, X. (1996). Molecular analysis of SRY gene of seven 46,XY females. *Chin Med J Genet* **12**, 258–261.
- Zhou, C., Fu, J. J., Li, L. Y., and Lu, G. X. (2005). Two novel mutations in SRY gene form Chinese sex reversal XY females. *Yi Chuan Xue Bao* **32**, 443–449.

CHAPTER 4

THE *TSPY* GENE FAMILY

Yun-Fai Chris Lau, Tatsuo Kido, and Yunmin Li

*Division of Cell and Developmental Genetics,
Department of Medicine, VA Medical Center,
University of California, San Francisco,
4150 Clement Street,
San Francisco, CA 94121*

The testis-specific protein Y-encoded (*TSPY*) gene is one of the early genes identified on the human Y chromosome. It is tandemly repeated on the short arm of this chromosome, postulated to contain the gonadoblastoma locus responsible for predisposing dysfunctional germ cells to tumorigenesis. *TSPY* encodes a phosphoprotein harboring a conserved domain, termed SET/NAP, present in various proteins involved in cell cycle regulation, chromatin modeling, and transcription regulation. Six *TSPY*-like genes have been identified in different mammalian genomes. One in particular, designated as *TSPX*, is located on the syntenic region of the X chromosome. Both *TSPY* and *TSPX* maintain a similar gene organization with six and seven exons, respectively. *TSPX* encodes a protein with two additional domains, an N-terminal proline-rich domain and a carboxyl bipartite acidic domain, that are absent in *TSPY*. Both *TSPY* and *TSPX* possess contrasting properties in cell cycle regulation when they are ectopically expressed. Other autosomal members of this gene family are single-exon genes, postulated to be retrotransposons of *TSPY*. They encode similar-sized proteins that share high levels of homology at their SET/NAP domains, but diverge at the flanking regions. Specific mutations on the *TSPY*-Like 1 gene have been demonstrated to be responsible for the sudden infant death with dysgenesis of the testes syndrome. Hence, *TSPY* and *TSPY*-like genes are hypothesized to serve a variety of different physiological functions mediated by the conserved SET/NAP and unique domains in their respective proteins.

Keywords: Gonadoblastoma; *TSPY*; *TSPY*-like genes; cell cycle.

The Gonadoblastoma Locus and the TSPY Gene on the Human Y Chromosome

Gonadoblastomas are benign tumors, consisting of aggregates of large, round germ cells and immature Sertoli/granulosa cells surrounded by ovarian-type stroma (Scully, 1953; Scully, 1970), that arise most frequently (up to ~66%) in the dysgenetic gonads of intersex individuals who harbor in their genome either the entire or a partial Y chromosome (e.g. 46,XY or 45,X/46,XY) (Verp and Simpson, 1987). Patients with Turner syndrome, who have a 45,XO chromosome complement and residual Y chromosome material, are also at risk for developing gonadoblastomas, although at a much lower rate (7%–10%) (Gravholt *et al.*, 2000; Mazzanti *et al.*, 2005). These tumors are capable of synthesizing sex hormones, such as estrogen or testosterone, leading to either feminization or virilization of the dysgenetic gonads, respectively (Verp and Simpson, 1987; Mancilla *et al.*, 2003). Approximately 80% of intersex patients are phenotypic females, and 20% are phenotypic males (Verp and Simpson, 1987).

In 1987, David Page proposed the existence of the gonadoblastoma locus on the Y chromosome (GBY) to explain the high frequency of gonadoblastomas in the dysgenetic gonads of XY females (Page, 1987). The *GBY* gene is postulated to serve a normal function in the testis, but could predispose the dysgenetic gonads of intersex individuals to tumorigenesis (Page, 1987; Lau, 1999). Gonadal dysgenesis is thought to arise from the mutation or deletion of the sex-determining region Y (*SRY*) gene (Sinclair *et al.*, 1990) or other downstream sex-determining genes, while the *GBY* gene remains in the XY or XO/XY mosaic genome. Because normal females do not have the Y chromosome, the acquisition of the *GBY* gene could be considered as a gain of function in the dysgenetic gonads in females. For males, the *SRY* gene could be functional, while other sex-determining genes downstream of this primary switch gene might be affected, resulting in streaked or dysgenetic gonads/testes. Based on these hypotheses, the *GBY* gene could potentially act as an oncogene or a tumor-promoting gene in dysfunctional germ cells of sex-reversed or testis dysgenesis individuals.

Deletion mapping narrowed the location of the GBY locus to a small region on the short arm and the proximal region on the long arm of the Y chromosome (Salo *et al.*, 1995; Tsuchiya *et al.*, 1995; Lau, 1999). The transcriptional units of the testis-specific protein Y-encoded (*TSPY*) repeated

gene (Arnemann *et al.*, 1991; Zhang *et al.*, 1992) are primarily located on this GBY critical region, thereby positioning *TSPY* to be a significant candidate for this oncogenic locus. Indeed, *TSPY* is abundantly expressed in gonadoblastomas, testicular seminomas, and extragonadal germ cell tumors of male origin (Schnieders *et al.*, 1996; Hildenbrand *et al.*, 1999; Lau *et al.*, 2000; Honecker *et al.*, 2006; Kersemaekers *et al.*, 2005; Hoei-Hansen *et al.*, 2006); and possesses proliferative properties that could function as an oncogene/tumor promoter in human oncogenesis (Oram *et al.*, 2006). Hence, studies of a relatively rare and special form of germ cell tumor, gonadoblastoma, have identified a significant candidate gene that could potentially play an important oncogenic role(s) in the more common testicular germ cell tumors (TGCTs).

Properties of the Testis-Specific Protein Y-Encoded (*TSPY*) Gene

Early studies of the *TSPY* gene demonstrated that its functional units are 2.8 kb in size, and consist of 6 exons and 5 introns (Zhang *et al.*, 1992; Schnieders *et al.*, 1996) embedded in repeat units of ~20.5-kb EcoR1 DNA fragments (Zhang *et al.*, 1992). Sequencing of the male-specific region of the Y chromosome (MSY) in humans showed that the *TSPY* structural gene is embedded in a 20.4-kb unit, which is tandemly repeated ~35 times on the GBY critical region of a reference individual (Skaletsky *et al.*, 2003). Although the number of repeats varies among individuals and could range from 23 to 49 (Repping *et al.*, 2006), these repeat units show >98% sequence homology among both *TSPY* transcriptional units and their flanking regions. They constitute the largest and most homologous protein-coding tandem array identified so far in the human genome, and represent close to half of the 78 transcriptional units identified within the MSY on the Y chromosome (Skaletsky *et al.*, 2003).

TSPY has been postulated to serve a normal function in directing the spermatogonial cells to enter meiosis (Schnieders *et al.*, 1996; Lau, 1999). Recent studies suggested that *TSPY* could possess an additional mitotic function in the proliferation of embryonic gonocytes and adult spermatogonia (Honecker *et al.*, 2004). The *TSPY* gene is evolutionarily conserved on the Y chromosome of all placental mammals, such as the primates and artiodactyls (Vogel *et al.*, 1997), except the rodents. Similar to the

human situation, it is a repetitive gene on the Y chromosome. The rat has one functional *Tspsy* gene on its Y chromosome (Dechend *et al.*, 1998; Mazeyrat and Mitchell, 1998). In the murines, several *Apodemus* species and *Mus platythrix* possess a functional *Tspsy* gene; while other species in the *Mus* subgenus, including the laboratory mouse (*Mus musculus*), harbor an apparently nonfunctional (with in-frame and splice-junction mutations) *Tspsy* gene on their Y chromosomes (Schubert *et al.*, 2000). Several autosomal *TSPY*-like (*TSPY-L*) genes have been identified in both the mouse and human genomes (Vogel *et al.*, 1998b). Currently, it is uncertain which of these *Tspsy*-like genes could serve as a functional counterpart for *Tspsy* in the mouse.

TSPY encodes a predominant 38-kDa phosphoprotein of 308 amino acids. It shares tight homology to the product of the *SET* oncogene, initially identified from an intrachromosome 9 translocation in a patient with undifferentiated leukemia (von Lindern *et al.*, 1992; Adachi *et al.*, 1994a; Adachi *et al.*, 1994b). The SET oncoprotein is a 39-kDa phosphoprotein consisting of 277 amino acids. It has also been identified as the template-activating factor- $I\beta$ (*TAF-I β*), a host protein required for DNA replication and transcription of the adenovirus genome (Nagata *et al.*, 1995). Together with the nucleosome assembly protein-1 (NAP-1), they are founding members of a protein family designated as TSPY/SET/NAP (Vogel *et al.*, 1998b; Lau, 1999; Ozbun *et al.*, 2001).

Members of this protein family harbor a conserved domain of ~ 160 amino acids, termed the SET/NAP domain, that binds to the B-type cyclins and core histones (Kellogg *et al.*, 1995; Matsumoto *et al.*, 1999). They serve a diverse spectrum of functions, including DNA replication, transcription modulation/chromatin modeling, and cell cycle regulation (Nagata *et al.*, 1995; Compagnone *et al.*, 2000; Chai *et al.*, 2001; Zhang *et al.*, 2001; Canela *et al.*, 2003; Oram *et al.*, 2006). Mutations and/or dysregulation of members of this SET/NAP gene family have been associated with various forms of human cancers: leukemia for the *SET* oncoprotein and the cell division autoantigen-1 (*CDA1*) gene (von Lindern *et al.*, 1992; Adachi *et al.*, 1994a; Chai *et al.*, 2001); lung cancer for the differentially expressed nucleolar TGF- $\beta 1$ target (*DENT1*) gene (Ozbun *et al.*, 2003); and gonadoblastomas, testicular germ cell tumors, prostate cancer (Lau *et al.*, 2003), melanoma (Gallagher *et al.*, 2005), and hepatocellular carcinoma (Yin *et al.*, 2005) for the *TSPY* gene.

TSPX is an X-Located TSPY Homolog with Contrasting Properties

Four laboratories have independently isolated and characterized an X-located gene (at Xp11.22), recently designated as *TSPX* (Delbridge *et al.*, 2004), that shares significant homologies with *TSPY* and *SET*. In all instances, *TSPX* was isolated by exploratory cloning strategies and was designated separately as the cutaneous T-cell lymphoma-associated tumor antigen *SE20-4*, (Eichmuller *et al.*, 2001), the *CDA1* gene (Chai *et al.*, 2001), and the *DENTT* gene (Ozbun *et al.*, 2001). Both *CDA1* and *DENTT* have been studied in significant detail. Although they were described as possessing a SET/NAP/TSPY domain in their encoded proteins, their identity as the homolog of *TSPY* was not obvious until the structure and mapping of these genes were studied recently (Delbridge *et al.*, 2004).

TSPX has been mapped to the syntenic region harboring the homologs of other Y genes on the X chromosome in humans and mice. Both *TSPX* and *TSPY* maintain a similar gene organization (Fig. 1). The *TSPX* gene is about 6.3 kb in size and harbors seven exons; it encodes an ~80-kDa protein of 693 amino acids. *TSPY* is 2.8 kb in size and harbors six exons; it encodes a variety of polymorphic proteins, with the main product being a protein with 308 amino acids and a calculated molecular weight of 35 kDa. The homologous regions of both *TSPX* and *TSPY* are encoded by exons 2–5 of both genes, and have highly conserved sequence homology and

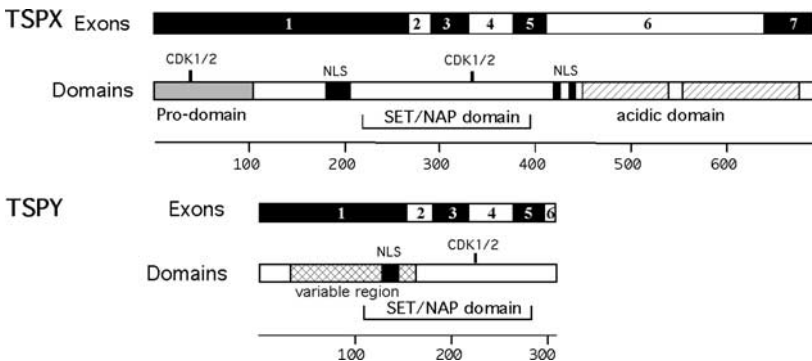

Fig. 1. Organization of human *TSPX* and *TSPY* exons and corresponding protein domains.

exon–intron organization. These portions of the proteins also harbor the SET/NAP domain. TSPX differs from TSPY by having an N-terminal proline-rich domain and a carboxyl bipartite acidic domain, encoded by exon 1 and exons 6–7, respectively. Both proteins are phosphorylated, presumably by cyclin-dependent kinases (CDKs) (Chai *et al.*, 2001) and other protein kinases (Krick *et al.*, 2006). TSPY could be located in both the cytoplasm and nuclei of expressing cells. The phosphorylation of the tyrosine at residue #300 of the predominant TSPY isoform by CK2 kinase has been demonstrated to be essential for its nuclear translocation (Krick *et al.*, 2006).

Significantly, overexpression of *TSPX* (*CDA1*) arrests cell growth at the G₂/M phase of the cell cycle (Chai *et al.*, 2001). TSPX is localized at the nucleus and nucleolus of the cells. Such cell growth inhibitory effects were mapped to the carboxyl acidic domain and two CDK1/2 phosphorylation sites, which are located at the proline-rich domain and the SET/NAP domain. The latter phosphorylation site is also conserved at the SET/NAP domain of the TSPY protein. Targeted mutations of both phosphorylation sites or truncation of the acidic domain of TSPX eliminates its growth inhibition. Importantly, overexpression of the SET protein also arrests cell proliferation, specifically at the G₂/M phase (Canela *et al.*, 2003). Such growth-inhibitory effects of SET were also mapped to its acidic carboxyl domain (Canela *et al.*, 2003), thereby ascertaining the importance of the acidic carboxyl domain of both SET and TSPX in cell cycle regulation. SET binds the mitotic cyclin B and, in collaboration with other factors, affects the cyclin B–CDK1 activities (Canela *et al.*, 2003; Carujo *et al.*, 2006). Normally, *TSPX* (*DENT1*) is expressed in a wide spectrum of tissues, with major sites in the brain, lung, thymus, adrenal, pituitary, smooth muscle, testis, and ovary of adult mice. It is initially expressed in the heart and the primitive brain of E8 mouse embryos; the embryonic expression then gradually expands to other tissues at later stages and reaches the ubiquitous pattern in adults (Ozbun *et al.*, 2003; Ozbun *et al.*, 2005).

Overexpression of *TSPY* potentiates cell proliferation in cultured cells and promotes tumor growth in nude mice (Oram *et al.*, 2006). It probably mediates such proliferative effect(s) at the G₂/M checkpoints, since cells overexpressing *TSPY* transit the G₂/M phase more rapidly than those repressing its expression. These cell cycle effects are in contrast with

those of *TSPX* (*CDA1*). Both genes encode relatively homologous proteins with a conserved SET/NAP domain, with the exception of the carboxyl acidic tail that is absent in TSPY. Since the cell cycle inhibitory effect(s) of TSPX has been mapped to this portion of the molecule, the differences in cell cycle properties between TSPX and TSPY could be attributed to the presence and absence of the carboxyl acidic domain in the respective proteins.

Microarray analysis demonstrates that ectopic TSPY expression primarily affects genes in three cellular processes: cell cycle regulation, phosphate transport, and neuromuscular development (Oram *et al.*, 2006). Among the cell cycle genes, *TSPY* upregulates several oncogenes [epidermal growth factor receptor (*ERBB*), and members of the *WNT* and *RAS* oncogenes], growth factors (*PDGFC*, *EGF*-related, *ANKRD15*, *RGC32*, *NANOS1*), cyclin D2, a histone acetyltransferase (*EP300*), an apoptosis inhibitor (*GSPT1*), and an antigen (*CD24*) highly expressed in small cell lung carcinoma. The downregulated genes include an inhibitor for *CDK4/CDK6*, transforming growth factor β 3, a proapoptotic factor (*IGFB3*), and an inhibitor of MAP kinases (dual-specificity phosphatase 5). In particular, the *CCND2* gene (which encodes cyclin D2) and another upregulated gene, the tetratricopeptide repeats (*TMTCl*), reside on chromosome 12p, which is frequently amplified and expressed at high levels in testicular germ cell tumors. Cyclin D2 complexes with CDK4 or CDK6 to mediate G₁/S transition and promote cell proliferation; *CCND2* is upregulated in cells overexpressing *TSPY*. Conversely, *CDKN2B* encodes an inhibitor (INK4B) of cyclin D2 activities by acting on CDK4 and CDK6; it is downregulated in the same cells. The loss of INK4 kinase inhibitors has been postulated to be important for the progression from carcinoma *in situ* (CIS) to invasive germ cell tumors (Bartkova *et al.*, 2000). Significantly, *NANOS1* is the homolog of the *Drosophila nanos* gene, which is critical for the development and maintenance of germ stem cells in both sexes. It is expressed in the spermatogonia and spermatocytes of human testes, and has been postulated to be important for the development of germ stem cells in humans (Jaruzelska *et al.*, 2003). The upregulation of this gene is extremely interesting, as it supports the role of *TSPY* in germ stem cell biology.

Studies so far suggest that *TSPX* is expressed in normal and cancerous somatic cells (Chai *et al.*, 2001; Eichmuller *et al.*, 2001; Ozbun *et al.*, 2001;

Ozbun *et al.*, 2003; Ozbun *et al.*, 2005), while *TSPY* is expressed primarily in germ cells (Zhang *et al.*, 1992; Schnieders *et al.*, 1996; Lau *et al.*, 2000; Honecker *et al.*, 2004) and tumors of male origin (Lau *et al.*, 2003; Gallagher *et al.*, 2005; Yin *et al.*, 2005; Hoei-Hansen *et al.*, 2006). To determine if they could be coexpressed in testicular germ cell tumors and their precursor CIS, we examined the expression patterns of *TSPY* and *TSPX* via immunofluorescence analysis of 10 cases of seminoma and 4 cases of nonseminoma consisting of yolk sac tumors and embryonal carcinomas, some of which also harbored adjacent CIS. *TSPX* was not expressed in any of these germ cell tumors, except in one case where there was significant infiltration of lymphocytes into the germ cell tumor (Fig. 2). *TSPX* was expressed in the nuclei of the lymphocytes, while *TSPY* was positive in the tumor germ cells. Such mutual exclusion raises the possibility that the cell

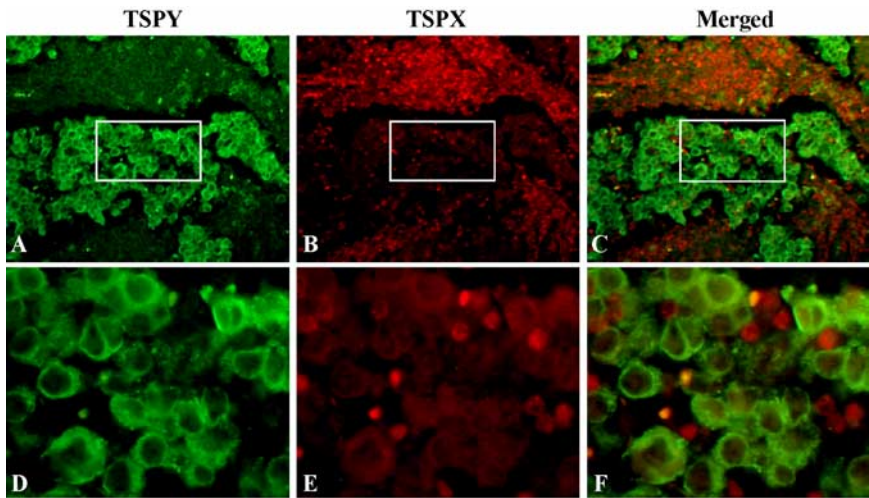

Fig. 2. TSPY and TSPX are differentially expressed in a case of human seminoma. Immunostaining shows that *TSPY* and *TSPX* are rarely expressed together in testicular germ cell tumors. In a rare case of seminoma with lymphocyte infiltration of the germ cell tumor — in which *TSPY* (A and D, green) and *TSPX* (DENTT) (B and E, red) expression were detectable by immunofluorescence — *TSPY* was primarily located on the tumor germ cells, while *TSPX* was detected mainly on the nuclei of the infiltrating lymphocytes. They did not show any significant colocalization of their respective proteins in the same cells. *TSPY* monoclonal antibody #7 (Kido and Lau, 2005) and DENTT (*TSPX*) polyclonal antibody (AbCam, ab10318) were used for immunofluorescence analysis. C is a merged image of A and B. Boxed areas in A, B, and C are enlarged in D, E, and F, respectively.

cycle functions of TSPY and TSPX could be antagonistic in testicular germ cell tumors.

Organization of TSPY-Like Genes and Proteins

Currently, six *TSPY*-like genes have been identified in the genomes of humans and several species of mammals (Table 1). *TSPY*-Like 2 (*TSPY-L2*) is *TSPX* and is evolutionarily conserved on the X chromosome of all mammals (except cattle, which harbor a highly homologous *TSPY-L2* gene on chromosome 25). All other *TSPY*-like genes are located on various autosomes (except for *TSPY-L6*, which is absent in rodents). These genes encode proteins of slightly different sizes that harbor a SET/NAP domain and belong to a cluster of orthologous group (COG) of proteins, termed DNA replication factor/protein phosphatase inhibitor SET/SPR-2 (KOG1508) (Tatusov *et al.*, 1997; Tatusov *et al.*, 2003), the members of which are present in many eukaryotes including mammals, worms, pufferfish, and fruit flies. The *TSPY* and *TSPY*-like genes constitute a subfamily of this COG.

Only *TSPY* and *TSPX* harbor both exons and introns in their respective genes (Fig. 3A). The primordial *TSPY-L2* gene could have derived from a common ancestral gene with SET/TAF- $I\beta$ and NAP-1, and resided on a pair

Table 1. Chromosomal location of *TSPY/TSPY*-like and *SET* genes among various mammals.

	Human (46,XY)	Chimpanzee (48,XY)	Mouse (40,XY)	Rat (42,XY)	Dog (78,XY)	Cattle (60,XY)
<i>TSPY-L1</i>	6	5	10	20	12	5
<i>TSPX/TSPY-L2</i>	X	X	X	X	X	25*
<i>TSPY-L3</i>	20	21	2	3	24	13
<i>TSPY-L4</i>	6	5	10	20	12	Scaffold [†]
<i>TSPY-L5</i>	8	7	15	7	29	12
<i>TSPY-L6</i>	2	12	—	—	10	11
<i>TSPY</i>	Y	Y	Y	Y	Y	Y
<i>SET/TAF-Iβ</i>	9	11	2	3	9	11

Note: TSPY-like genes are identified by sequence homology analysis with respective human/mouse genes. Chromosome mapping was performed with BLAT analysis of available genome sequence databases of respective mammals at <http://www.genome.ucsc.edu/> (Kent, 2002; Hinrichs *et al.*, 2006).

[†]Scaffold, sequence identified but not mapped on to any chromosome.

*Provisional.

A

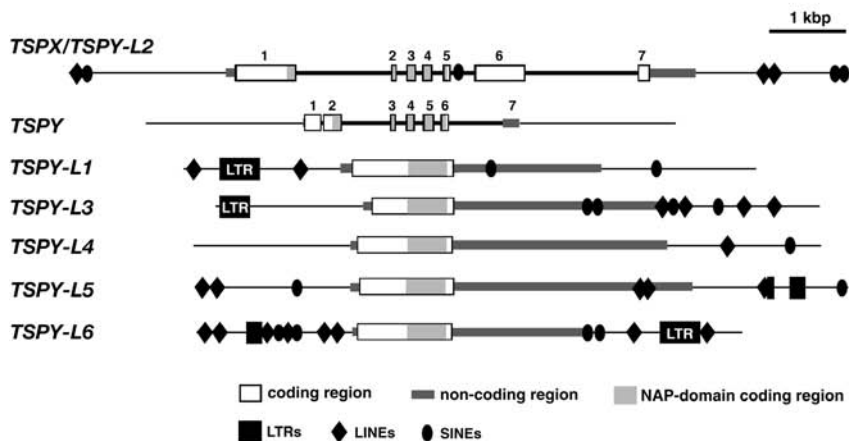

B

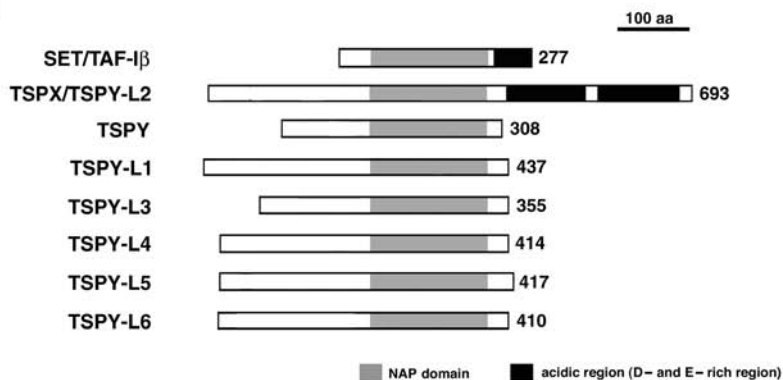

C

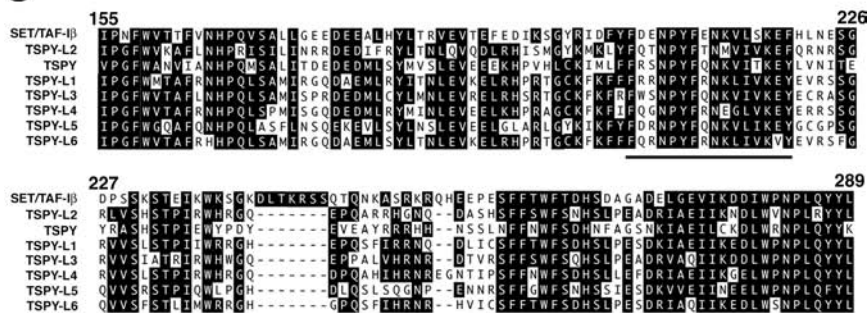

of chromosomes that evolved into the proto-X and proto-Y chromosomes (Fig. 4). During the evolution of the sex chromosomes, *TSPY* might have lost the N-terminal proline-rich and C-terminal acidic domains before its sequence was amplified on the Y chromosome, while the *TSPX/TSPY-L2* gene maintained structural similarity to the common ancestral gene into the present. The autosomal *TSPY*-like genes have a single exon and could have derived from *TSPY* via retrotransposition events, as their encoded proteins lack the carboxyl acidic domain present in *TSPX* (Fig. 3B). Indeed, numerous long terminal repeat (LTR) retrotransposons — as well as non-LTR long interspersed nuclear element (LINE) and short interspersed nuclear element (SINE) transposon sequences (Kazazian, 2004; Ohshima and Okada, 2005) — are scattered around the flanking regions of the respective *TSPY*-like genes (Fig. 3A), thus supporting the postulation that they were derived from the retrotransposition of transcripts originating from this Y chromosome gene. Alternatively, these *TSPY*-like genes could have derived from duplication of the initial retrotransposon, resulting in multiple single-exon genes on the autosomes.

Except for *TSPX/TSPY-L2*, all *TSPY*-like genes encode proteins that are highly conserved at their carboxyl termini, but variable at their N-termini (Fig. 3B). The alignment of their protein sequences suggests that

←

Fig. 3. Gene organization, protein structure, and homologous domains of human *TSPY*, *TSPY*-like, and *SET/TAF-1 β* genes. **A.** *TSPY* and *TSPX/TSPY-L2* are the only two genes of this family containing exons interrupted by introns. *TSPY-L1* and *TSPY-L3–6* are single-exon genes, possibly arisen from retrotransposition of *TSPY* transcripts: numerous LTRs, LINEs, and SINEs — characteristics of retrotransposons — are present in their flanking sequences (identified by the web-based program RepeatMasker, developed by AFA Smit, R Hubley, & P Green, <http://repeatmasker.org>). **B.** Protein structures of *TSPY* family. All members of the *TSPY* gene family encode protein products that are highly homologous at their carboxyl portions harboring a SET/NAP domain. The N-terminal portions are unique to the individual members. *TSPX/TSPY-L2*, similar to *SET/TAF-1 β* , contains an additional acidic domain at its carboxyl terminus. The number of amino acids for each protein is listed immediately after the carboxyl end of the respective protein. **C.** Protein alignment of the conserved SET/NAP domains of the human *TSPY* family members. The numbers at the top correspond to the residue positions of the human *TSPY* protein. Two highly conserved regions are underlined. The accession numbers for the protein sequences are as follows: *TSPY*, NP_003299; *TSPY-L1*, NM_003309; *TSPX/TSPY-L2*, AF254794; *TSPY-L3*, BC101556; *TSPY-L4*, NM_021648; *TSPY-L5*, NM_033512; *TSPY-L6*, BC068576; and *SET/TAF-1 β* , M93651.

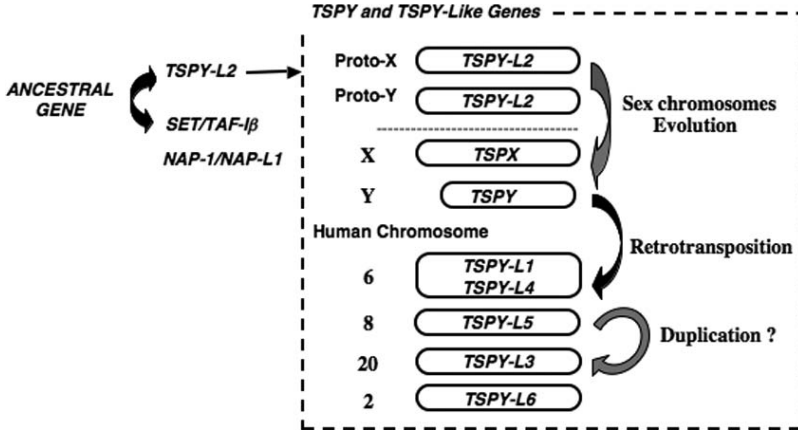

Fig. 4. Diagrammatic illustration of probable evolutionary events for the TSPY and TSPY-like genes. The primordial TSPY-L2 gene probably shared a common ancestral gene as the SET/TAF-I β and the NAP and NAP-related genes. It was located on a pair of proto-X and proto-Y chromosomes, which eventually evolved into the present-day X and Y chromosomes. TSPX maintained the structure of the primordial TSPY-L2 gene, while TSPY lost its carboxyl acidic domain before it was amplified on the Y chromosome. The autosomal TSPY-like genes arose from the retrotransposition of TSPY transcripts, since they encode proteins with a conserved SET/NAP domain, but lack the carboxyl acidic domain present in TSPX.

homologies are present only at the 160-residue SET/NAP domain and at the short flanking regions (Fig. 3C). The conservation of this domain among the TSPY and TSPY-like proteins suggests that it must have an important role(s) in the biological functions of this protein subfamily.

Specific mutations of the *TSPY-L1* gene on chromosome 6 have been identified with the sudden infant death with dysgenesis of the testes (SIDDT) syndrome (Puffenberger *et al.*, 2004). Notably, one frameshift mutation truncates the coding sequence for the SET/NAP domain from its open reading frame. The mutated protein is incapable of translocation to the nuclei and might contribute to the disease process. Further studies demonstrate that *TSPY-L1* interacts with ZFP106 at its SET/NAP domain and N-terminal flanking region, important for such nuclear translocation and the formation of nuclear bodies of undefined function(s) (Grasberger and Bell, 2005).

Currently, the exact functions of *TSPY* and *TSPY*-like genes are uncertain. As discussed above, TSPY and TSPX possess contrasting functions in cell cycle regulation that have been attributed to the absence and presence

of an acidic domain at their respective carboxyl termini. Hence, the unique portions, flanking the conserved SET/NAP domain, of the TSPY and TSPY-like proteins could be responsible for specifying the distinct functions of the respective members of the protein family.

Expression of *TSPY* and *TSPY*-Like Genes in the Mouse

To explore the possible functions of *TSPY* and *TSPY*-like genes, we have conducted a preliminary study on the expression patterns of members of this gene subfamily in adult mice, using specific primer sets and the reverse transcription–polymerase chain reaction technique (Table 2). The expression patterns for *Tspy*, *Tspx*, *Tspy-L1*, and *Tspy-L4* are relatively ubiquitous in many tissues, while *Tspy-L3* and *Tspy-L5* show some tissue specificity. The detection of transcripts from the *Tspy* gene is somewhat different in other species, including humans, in which the expression of this Y-located gene is restricted to the testis (Zhang *et al.*, 1992; Schnieders *et al.*, 1996; Vogel *et al.*, 1997). Previous studies suggested that the mouse *Tspy* is non-functional, due to the presence of stop codons in its open reading frame (Mazeyrat and Mitchell, 1998; Vogel *et al.*, 1998a).

If *Tspy* serves an important role(s) in the physiology of the testis, then one of the *Tspy*-like genes could potentially substitute for its function in the mouse testis. Analysis of developmental testes at various ages after birth shows that the expression patterns of both *Tspy* and *Tspy-L5* seem to increase with age, while those for *Tspy-L1* and *Tspy-L3* decrease in the same intervals (Fig. 5). Both *Tspx* and *Tspy-L4* show ubiquitous expression

Table 2. Expression of *Tspy* and *Tspy-L* genes in adult mouse tissues.

	Brain	Thymus	Heart	Liver	Spleen	Seminal vesicle	Prostate	Testis	Ovary
<i>Tspx/Tspy-L2</i>	+	+	+	+	+	+	–	+	+
<i>Tspy</i> *	+	+	+	+	+	–	–	+	–
<i>Tspy-L1</i>	+	+	+	+	+	+	–	+	+
<i>Tspy-L3</i>	+	+	–	–	+	–	–	+	+
<i>Tspy-L4</i>	+	+	+	+	+	+	–	+	+
<i>Tspy-L5</i>	+	–	+	–	–	–	–	+	+

*Pseudogene with in-frame stop codons. +, detectable; –, undetectable by RT-PCR.

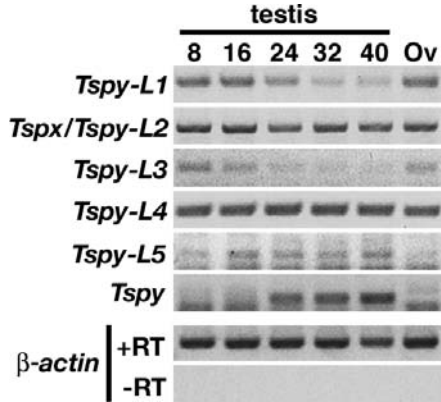

Fig. 5. Expression of *Tspy* and *Tspy*-like genes in developing testes and adult ovaries of mice. RT-PCR analysis with specific primers for respective members of the *Tspy* gene family were performed with total RNAs purified from testes of postnatal mice at 8, 16, 24, 32, and 40 days after birth, and from adult ovaries. β -actin was used as a reference.

patterns throughout these developmental stages. The expression of *Tspy*-like genes in the testis suggests that they could potentially play some roles in the physiology of this organ. Despite their differential expression, their exact functions will need to be defined by other experimental means, such as disease linkage analysis (e.g. with the SIDDT syndrome) and gene knockout studies.

Acknowledgments

This work was partially supported by grants from the Department of Defense Prostate Cancer Research Program, the VA Merit Research, and the Research Enhancement Award Program (REAP) on Prostate Cancer. Y-FC Lau is a Research Career Scientist of the Department of Veterans Affairs.

References

- Adachi, Y., Pavlakis, G. N., and Copeland, T. D. (1994a). Identification and characterization of SET, a nuclear phosphoprotein encoded by the translocation break point in acute undifferentiated leukemia. *J Biol Chem* **269**, 2258–2262.
- Adachi, Y., Pavlakis, G. N., and Copeland, T. D. (1994b). Identification of in vivo phosphorylation sites of SET, a nuclear phosphoprotein encoded by the translocation breakpoint in acute undifferentiated leukemia. *FEBS Lett* **340**, 231–235.

- Arnemann, J., Jakubiczka, S., Thuring, S., and Schmidtke, J. (1991). Cloning and sequence analysis of a human Y-chromosome-derived, testicular cDNA, TSPY. *Genomics* **11**, 108–114.
- Bartkova, J., Thullberg, M., Rajpert-De Meyts, E., Skakkebaek, N. E., and Bartek, J. (2000). Cell cycle regulators in testicular cancer: loss of p18INK4C marks progression from carcinoma in situ to invasive germ cell tumours. *Int J Cancer* **85**, 370–375.
- Canela, N., Rodriguez-Vilarrupla, A., Estanyol, J. M., Diaz, C., Pujol, M. J., Agell, N., and Bachs, O. (2003). The SET protein regulates G₂/M transition by modulating cyclin B-cyclin-dependent kinase 1 activity. *J Biol Chem* **278**, 1158–1164.
- Carujo, S., Estanyol, J. M., Ejarque, A., Agell, N., Bachs, O., and Pujol, M. J. (2006). Glyceraldehyde 3-phosphate dehydrogenase is a SET-binding protein and regulates cyclin B-cdk1 activity. *Oncogene* **25**, 4033–4042.
- Chai, Z., Sarcevic, B., Mawson, A., and Toh, B. H. (2001). SET-related cell division autoantigen-1 (CDA1) arrests cell growth. *J Biol Chem* **276**, 33665–33674.
- Compagnone, N. A., Zhang, P., Vigne, J. L., and Mellon, S. H. (2000). Novel role for the nuclear phosphoprotein SET in transcriptional activation of P450c17 and initiation of neurosteroidogenesis. *Mol Endocrinol* **14**, 875–888.
- Dechend, F., Schubert, S., Nanda, I., Vogel, T., Schmid, M., and Schmidtke, J. (1998). Organization and expression of rat Tspy. *Cytogenet Cell Genet* **83**, 270–274.
- Delbridge, M. L., Longepied, G., Depetris, D., Mattei, M. G., Disteche, C. M., Marshall Graves, J. A., and Mitchell, M. J. (2004). TSPY, the candidate gonadoblastoma gene on the human Y chromosome, has a widely expressed homologue on the X — implications for Y chromosome evolution. *Chromosome Res* **12**, 345–356.
- Eichmuller, S., Usener, D., Dummer, R., Stein, A., Thiel, D., and Schadendorf, D. (2001). Serological detection of cutaneous T-cell lymphoma-associated antigens. *Proc Natl Acad Sci U S A* **98**, 629–634.
- Gallagher, W. M., Bergin, O. E., Rafferty, M., Kelly, Z. D., Nolan, I. M., Fox, E. J., Culhane, A. C., McArdle, L., Fraga, M. F., Hughes, L., *et al.* (2005). Multiple markers for melanoma progression regulated by DNA methylation: insights from transcriptomic studies. *Carcinogenesis* **26**, 1856–1867.
- Grasberger, H., and Bell, G. I. (2005). Subcellular recruitment by TSG118 and TSPYL implicates a role for zinc finger protein 106 in a novel developmental pathway. *Int J Biochem Cell Biol* **37**, 1421–1437.
- Gravholt, C. H., Fedder, J., Naeraa, R. W., and Muller, J. (2000). Occurrence of gonadoblastoma in females with Turner syndrome and Y chromosome material: a population study. *J Clin Endocrinol Metab* **85**, 3199–3202.
- Hildenbrand, R., Schroder, W., Brude, E., Schepler, A., Konig, R., Stutte, H. J., and Arnemann, J. (1999). Detection of TSPY protein in a unilateral microscopic gonadoblastoma of a Turner mosaic patient with a Y-derived marker chromosome. *J Pathol* **189**, 623–626.
- Hinrichs, A. S., Karolchik, D., Baertsch, R., Barber, G. P., Bejerano, G., Clawson, H., Diekhans, M., Furey, T. S., Harte, R. A., Hsu, F., *et al.* (2006). The UCSC genome browser database: update 2006. *Nucleic Acids Res* **34**, D590–D598.
- Hoei-Hansen, C. E., Sehested, A., Juhler, M., Lau, Y. F., Skakkebaek, N. E., Laursen, H., and Rajpert-De Meyts, E. (2006). New evidence for the origin of intracranial germ cell tumours from primordial germ cells: expression of pluripotency and cell differentiation markers. *J Pathol* **209**, 25–33.

- Honecker, F., Stoop, H., de Krijger, R. R., Lau, Y.-F. C., Bokemeyer, C., and Looijenga, L. H. (2004). Pathobiological implications of the expression of markers of testicular carcinoma in situ by fetal germ cells. *J Pathol* **203**, 849–857.
- Honecker, F., Stoop, H., Mayer, F., Bokemeyer, C., Castrillon, D. H., Lau, Y. F., Looijenga, L. H., and Oosterhuis, J. W. (2006). Germ cell lineage differentiation in non-seminomatous germ cell tumours. *J Pathol* **208**, 395–400.
- Jaruzelska, J., Kotecki, M., Kusz, K., Spik, A., Firpo, M., and Reijo Pera, R. A. (2003). Conservation of a Pumilio–Nanos complex from *Drosophila* germ plasm to human germ cells. *Dev Genes Evol* **213**, 120–126.
- Kazazian, H. H., Jr. (2004). Mobile elements: drivers of genome evolution. *Science* **303**, 1626–1632.
- Kellogg, D. R., Kikuchi, A., Fujii-Nakata, T., Turck, C. W., and Murray, A. W. (1995). Members of the NAP/SET family of proteins interact specifically with B-type cyclins. *J Cell Biol* **130**, 661–673.
- Kent, W. J. (2002). BLAT — the BLAST-like alignment tool. *Genome Res* **12**, 656–664.
- Kersemaekers, A. M., Honecker, F., Stoop, H., Cools, M., Molier, M., Wolffenbuttel, K., Bokemeyer, C., Li, Y., Lau, Y. F., Oosterhuis, J. W., and Looijenga, L. H. (2005). Identification of germ cells at risk for neoplastic transformation in gonadoblastoma: an immunohistochemical study for OCT3/4 and TSPY. *Hum Pathol* **36**, 512–521.
- Kido, T., and Lau, Y. F. (2005). A Cre gene directed by a human TSPY promoter is specific for germ cells and neurons. *Genesis* **42**, 263–275.
- Krick, R., Aschrafi, A., Hasgun, D., and Arnemann, J. (2006). CK2-dependent C-terminal phosphorylation at T(300) directs the nuclear transport of TSPY protein. *Biochem Biophys Res Commun* **341**, 343–350.
- Lau, Y. F. (1999). Gonadoblastoma, testicular and prostate cancers, and the TSPY gene. *Am J Hum Genet* **64**, 921–927.
- Lau, Y. F., Chou, P., Iezzoni, J., Alonzo, J., and Komuves, L. (2000). Expression of a candidate gene for the gonadoblastoma locus in gonadoblastoma and testicular seminoma. *Cytogenet Cell Genet* **91**, 160–164.
- Lau, Y. F., Lau, H. W., and Komuves, L. G. (2003). Expression pattern of a gonadoblastoma candidate gene suggests a role of the Y chromosome in prostate cancer. *Cytogenet Genome Res* **101**, 250–260.
- Mancilla, E. E., Poggi, H., Repetto, G., Rumie, H., Garcia, H., Ugarte, F., Hidalgo, S., Jara, A., Muzzo, S., Panteon, E., et al. (2003). Y chromosome sequences in Turner’s syndrome: association with virilization and gonadoblastoma. *J Pediatr Endocrinol Metab* **16**, 1157–1163.
- Matsumoto, K., Nagata, K., Miyaji-Yamaguchi, M., Kikuchi, A., and Tsujimoto, M. (1999). Sperm chromatin decondensation by template activating factor I through direct interaction with basic proteins. *Mol Cell Biol* **19**, 6940–6952.
- Mazeyrat, S., and Mitchell, M. J. (1998). Rodent Y chromosome TSPY gene is functional in rat and non-functional in mouse. *Hum Mol Genet* **7**, 557–562.
- Mazzanti, L., Cicognani, A., Baldazzi, L., Bergamaschi, R., Scarano, E., Strocchi, S., Nicoletti, A., Mencarelli, F., Pittalis, M., Forabosco, A., and Cacciari, E. (2005). Gonadoblastoma in Turner syndrome and Y-chromosome-derived material. *Am J Med Genet A* **135**, 150–154.

- Nagata, K., Kawase, H., Handa, H., Yano, K., Yamasaki, M., Ishimi, Y., Okuda, A., Kikuchi, A., and Matsumoto, K. (1995). Replication factor encoded by a putative oncogene, set, associated with myeloid leukemogenesis. *Proc Natl Acad Sci U S A* **92**, 4279–4283.
- Ohshima, K., and Okada, N. (2005). SINEs and LINEs: symbionts of eukaryotic genomes with a common tail. *Cytogenet Genome Res* **110**, 475–490.
- Oram, S. W., Liu, X. X., Lee, T. L., Chan, W. Y., and Lau, Y. F. (2006). TSPY potentiates cell proliferation and tumorigenesis by promoting cell cycle progression in HeLa and NIH3T3 cells. *BMC Cancer* **6**, 154.
- Ozbun, L. L., Martinez, A., Angdisen, J., Umphress, S., Kang, Y., Wang, M., You, M., and Jakowlew, S. B. (2003). Differentially expressed nucleolar TGF-beta1 target (DENTT) in mouse development. *Dev Dyn* **226**, 491–511.
- Ozbun, L. L., Martinez, A., and Jakowlew, S. B. (2005). Differentially expressed nucleolar TGF-beta1 target (DENTT) shows tissue-specific nuclear and cytoplasmic localization and increases TGF-beta1-responsive transcription in primates. *Biochim Biophys Acta* **1728**, 163–180.
- Ozbun, L. L., You, L., Kiang, S., Angdisen, J., Martinez, A., and Jakowlew, S. B. (2001). Identification of differentially expressed nucleolar TGF-beta1 target (DENTT) in human lung cancer cells that is a new member of the TSPY/SET/NAP-1 superfamily. *Genomics* **73**, 179–193.
- Page, D. C. (1987). Hypothesis: a Y-chromosomal gene causes gonadoblastoma in dysgenetic gonads. *Development* **101**(Suppl), 151–155.
- Puffenberger, E. G., Hu-Lince, D., Parod, J. M., Craig, D. W., Dobrin, S. E., Conway, A. R., Donarum, E. A., Strauss, K. A., Dunckley, T., Cardenas, J. F., *et al.* (2004). Mapping of sudden infant death with dysgenesis of the testes syndrome (SIDDT) by a SNP genome scan and identification of TSPYL loss of function. *Proc Natl Acad Sci U S A* **101**, 11689–11694.
- Repping, S., van Daalen, S. K., Brown, L. G., Korver, C. M., Lange, J., Marszalek, J. D., Pyntikova, T., van der Veen, F., Skaletsky, H., Page, D. C., and Rozen, S. (2006). High mutation rates have driven extensive structural polymorphism among human Y chromosomes. *Nat Genet* **38**, 463–467.
- Salo, P., Kaariainen, H., Petrovic, V., Peltomaki, P., Page, D. C., and de la Chapelle, A. (1995). Molecular mapping of the putative gonadoblastoma locus on the Y chromosome. *Genes Chromosomes Cancer* **14**, 210–214.
- Schnieders, F., Dork, T., Arnemann, J., Vogel, T., Werner, M., and Schmidtke, J. (1996). Testis-specific protein, Y-encoded (TSPY) expression in testicular tissues. *Hum Mol Genet* **5**, 1801–1807.
- Schubert, S., Dechend, F., Skawran, B., Krawczak, M., and Schmidtke, J. (2000). Molecular evolution of the murine tspy genes. *Cytogenet Cell Genet* **91**, 239–242.
- Scully, R. E. (1953). Gonadoblastoma: a gonadal tumor related to the dysgerminoma (seminoma) and capable of sex-hormone production. *Cancer* **6**, 455–463.
- Scully, R. E. (1970). Gonadoblastoma. A review of 74 cases. *Cancer* **25**, 1340–1356.
- Sinclair, A. H., Berta, P., Palmer, M. S., Hawkins, J. R., Griffiths, B. L., Smith, M. J., Foster, J. W., Frischauf, A. M., Lovell-Badge, R., and Goodfellow, P. N. (1990). A gene from the human sex-determining region encodes a protein with homology to a conserved DNA-binding motif. *Nature* **346**, 240–244.

- Skaletsky, H., Kuroda-Kawaguchi, T., Minx, P. J., Cordum, H. S., Hillier, L., Brown, L. G., Repping, S., Pyntikova, T., Ali, J., Bieri, T., et al. (2003). The male-specific region of the human Y chromosome is a mosaic of discrete sequence classes. *Nature* **423**, 825–837.
- Tatusov, R. L., Fedorova, N. D., Jackson, J. D., Jacobs, A. R., Kiryutin, B., Koonin, E. V., Krylov, D. M., Mazumder, R., Mekhedov, S. L., Nikolskaya, A. N., et al. (2003). The COG database: an updated version includes eukaryotes. *BMC Bioinformatics* **4**, 41.
- Tatusov, R. L., Koonin, E. V., and Lipman, D. J. (1997). A genomic perspective on protein families. *Science* **278**, 631–637.
- Tsuchiya, K., Reijo, R., Page, D. C., and Disteché, C. M. (1995). Gonadoblastoma: molecular definition of the susceptibility region on the Y chromosome. *Am J Hum Genet* **57**, 1400–1407.
- Verp, M. S., and Simpson, J. L. (1987). Abnormal sexual differentiation and neoplasia. *Cancer Genet Cytogenet* **25**, 191–218.
- Vogel, T., Boettger-Tong, H., Nanda, I., Dechend, F., Agulnik, A. I., Bishop, C. E., Schmid, M., and Schmidtke, J. (1998a). A murine TSPY. *Chromosome Res* **6**, 35–40.
- Vogel, T., Dechend, F., Manz, E., Jung, C., Jakubiczka, S., Fehr, S., Schmidtke, J., and Schnieders, F. (1997). Organization and expression of bovine TSPY. *Mamm Genome* **8**, 491–496.
- Vogel, T., Dittrich, O., Mehraein, Y., Dechend, F., Schnieders, F., and Schmidtke, J. (1998b). Murine and human TSPYL genes: novel members of the TSPY-SET-NAPIL1 family. *Cytogenet Cell Genet* **81**, 265–270.
- von Lindern, M., van Baal, S., Wiegant, J., Raap, A., Hagemeijer, A., and Grosveld, G. (1992). Can, a putative oncogene associated with myeloid leukemogenesis, may be activated by fusion of its 3' half to different genes: characterization of the set gene. *Mol Cell Biol* **12**, 3346–3355.
- Yin, Y. H., Li, Y. Y., Qiao, H., Wang, H. C., Yang, X. A., Zhang, H. G., Pang, X. W., Zhang, Y., and Chen, W. F. (2005). TSPY is a cancer testis antigen expressed in human hepatocellular carcinoma. *Br J Cancer* **93**, 458–463.
- Zhang, J. S., Yang-Feng, T. L., Muller, U., Mohandas, T. K., de Jong, P. J., and Lau, Y. F. (1992). Molecular isolation and characterization of an expressed gene from the human Y chromosome. *Hum Mol Genet* **1**, 717–726.
- Zhang, P., Compagnone, N. A., Fiore, C., Vigne, J. L., Culp, P., Musci, T. J., and Mellon, S. H. (2001). Developmental gonadal expression of the transcription factor SET and its target gene, P450c17 (17 α -hydroxylase/c17,20 lyase). *DNA Cell Biol* **20**, 613–624.

CHAPTER 5

STRUCTURE AND FUNCTION OF AZFa LOCUS IN HUMAN SPERMATOGENESIS

Peter H. Vogt, Hans-Juergen Ditton, Christine Kamp, and Jutta Zimmer

*Section Molecular Genetics & Infertility,
Department of Gynecological Endocrinology & Reproductive Medicine,
University of Heidelberg,
D-69115 Heidelberg, Germany*

The AZFa locus functional in human spermatogenesis has been mapped to proximal Yq11 by molecular deletion analysis. Infertile men with complete aplasia of germ cells and only Sertoli cells in their testis tubules (SCO syndrome) are frequently found to have a genomic DNA deletion in this Y region, caused by the recombination of two homologous HERV15 sequence blocks. This AZFa deletion extends 792 kb and includes two functional Y genes, *USP9Y* and *DBY*. Its frequency of deletion might be different in distinct Y chromosomal haplogroups (D2* and J*). Mutation analyses and positional expression analyses in human testis tissue sections have indicated that probably both genes are translationally controlled in the male germ line. Accordingly, their male-specific cellular functions are different from that of their functional homologs on the X chromosome, *USP9X* and *DBX*, explaining the AZFa patients' pathology. Comparative sequence analysis of the X–Y homologous genome region in proximal Yq11 revealed that the AZFa locus might also include the *UTY* gene mapped distal to *DBY*, like *UTX* is mapped distal to *DBX* in Xp11.4. This chromatin domain has been evolutionarily conserved on the sex chromosomes for 100 million years and has probably evolved before mammalian radiation. Molecular deletion mapping also points to an overlap of the AZFa locus with the HY antigen (HYA) locus in proximal Yq11, and with the gonadoblastoma Y (GBY) locus in proximal Yp11 and Yq11. Each AZFa gene expresses distinct HY antigens, the presence of which might be hazardous in the gonad cells of women with dysgenetic gonads and a Y chromosome in the karyotype 46,XY/45,XX by contributing to the expression of gonadoblastoma cells. The different expression profiles of the human *DBY* and its mouse *Dby* homolog suggest that the evolutionary pressure on Y genes functional for spermatogenesis in mouse and man might be different when considering the single

Corresponding author: Peter H. Vogt; e-mail: peter_vogt@med.uni-heidelberg.de

genes, but more comparable after setting the focus on the complete gene content of the mouse and human Y chromosomes, because they are involved in the same genetic networks controlling the spermatogenic germ cell maturation process.

Keywords: AZFa locus; X–Y homologous genes; human spermatogoniogenesis; germ line stem cells; Sertoli cell-only syndrome; gonadoblastoma; dysgenetic gonads.

Introduction

The azoospermia factor (AZF) locus in Yq11 was first mapped by cytogenetic observations of microscopically visible deletions of the Y chromosome in infertile patients that always affected Yq11 (Tiepolo and Zuffardi, 1976). Testicular tissue sections of azoospermic men with these Yq11 aberrations mostly displayed a severe disruption of spermatogenesis. This suggested an essential function of AZF for the cellular proliferation and differentiation of the human male germ cell. Numerous similar studies have confirmed this basic assumption (Sandberg, 1985). Moreover, when evaluating the individual histology of the patients' testicular tubules, an extension of the first observed phenotypes was indicated. It suggested that the AZF locus might be composed of more than one Y gene, each functioning at a distinct phase of the spermatogenic maturation process and probably located in different genomic subintervals of the genetically defined AZF locus in Yq11 (Vogt *et al.*, 1993). This assumption gained experimental support after it became possible to establish detailed molecular deletion maps of the human Y chromosome in different research groups. They were based first on Southern blots and the use of Y-specific probes selected from different Y-specific clone libraries (Bardoni *et al.*, 1991; Ferguson-Smith *et al.*, 1987; Ma *et al.*, 1992; Vergnaud *et al.*, 1986), and then on the collection of a large number of sequence-tagged sites (STSs) selected from large clones mapped in Yq11 (Foote *et al.*, 1992; Vollrath *et al.*, 1992; Kirsch *et al.*, 1996) and the application of PCR technology.

In the first large screening study with 370 genomic DNA samples of infertile men with a normal karyotype (46,XY), three different microdeletions were distinguished in Yq11 and were coined AZFa, AZFb, and AZFc, respectively (Vogt *et al.*, 1996). The observed Yq11 microdeletions occurred as a *de novo* mutation event, i.e. they were restricted to the patient's

Y chromosome and were not found in his family; thus, polymorphic Y rearrangements as their putative origins were excluded. They interrupted the patients' spermatogenesis at three different phases (Fig. 1): (1) A complete Sertoli cell-only (SCO) syndrome was observed in all patients with deletion of the complete AZFa interval, i.e. only Sertoli cells (no germ cells) were visible in the tubules of their testis tissue sections. (2) Arrest at the spermatocyte stage was observed in the testis tissue of all patients with deletion of the complete AZFb interval. The populations of spermatogonia and primary spermatocytes in all tubules analyzed were in the normal range; however, no postmeiotic germ cells were identified. (3) A gradual inhibition of the postmeiotic spermatid maturation process with a variable testicular pathology was found in patients with AZFc deletions in distal Yq11. In most tubules, only Sertoli cells were identified; but in some tubules, germ cells of different developmental stages were clearly visible and the occurrence of mature sperm cells (albeit in a low number) was repeatedly observed. Hypospermatogenesis seemed therefore to be the primary result of an AZFc deletion in distal Yq11. Association of the occurrence of AZFa and AZFb microdeletions with a specific testicular histology, then also described in numerous similar studies (for review, see e.g.: Krausz *et al.*, 2003; Schlegel, 2002; Vogt, 1998; Vogt, 2005a), confirmed not only the early prediction of a functional AZF locus in Yq11 (Tiepolo and Zuffardi, 1976), but also its functional distribution to different phases of human spermatogenesis (Vogt *et al.*, 1993). Therefore, AZF can now also be functionally subdivided into three distinct spermatogenesis loci: AZFa, AZFb, and AZFc (Fig. 1).

This review focuses on a detailed description of the structure and function of the AZFa locus in human spermatogenesis. The AZFa deletion is frequently observed (9%–55%) only in men with a complete SCO syndrome (Foresta *et al.*, 1998; Blagosklonova *et al.*, 2000; Kamp *et al.*, 2001). This points to a function of the AZFa locus in early human germ cell development, also called spermatogoniogenesis. Our current knowledge of the human spermatogoniogenesis process, starting early during embryogenesis, is therefore given in the first section of this AZFa review. Then, the focus is set on an extensive discussion about the possible functional contribution(s) of the Y genes composing the AZFa locus to this early male-specific cell differentiation process, and the first results of their structure and putative spermatogenic function(s) are presented.

Molecular interval screen for *de novo* AZF microdeletion in Yq11

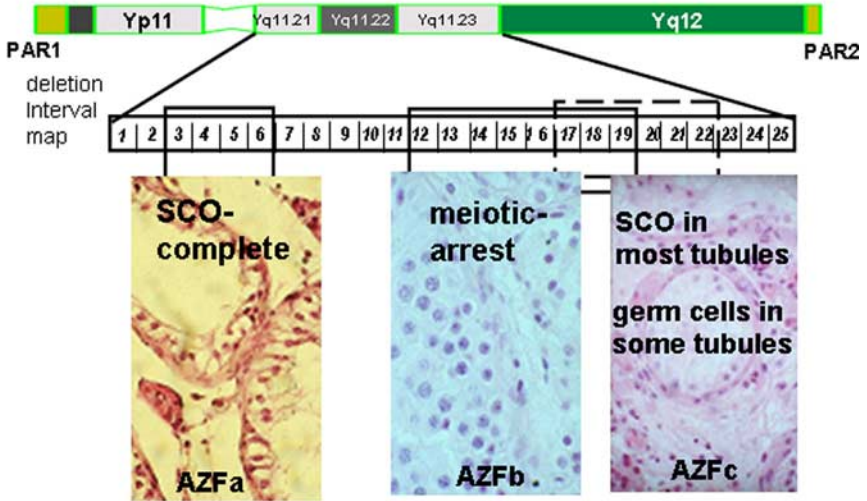

specific testicular pathology is associated with AZF deletions

Fig. 1. Molecular interval screening for AZF microdeletions in Yq11 occurring *de novo* only in the Y chromosome of infertile patients revealed three distinct subintervals: AZFa, AZFb, and AZFc in the deletion interval map (D1–D25) of Vogt *et al.* (1996). Each of these AZF deletions was associated with the presence of a specific pathology in the patient’s testicular tissue section, as indicated. AZFa deletion always caused a complete absence of germ cells, i.e. the Sertoli cell-only (SCO) syndrome. AZFb deletion always caused a meiotic arrest, so no postmeiotic germ cells were identified in their testis tubules. AZFc deletion caused SCO type II, according to Terada and Hatakeyama (1991), and a postmeiotic disruption phase of the spermatogenic cycle as the primary mutation event; this meant that the SCO was found in most tubules, although germ cells of a variable maturation state (i.e. a mixed atrophy) including mature sperms could be continuously found in some of the tubules as well. In some patients with AZFc deletion, small numbers of sperms were also found in the semen fluid. After Y chromosome sequence analysis was completed, a molecular overlap between the AZFb and AZFc deletion intervals, here indicated by a broken border line for the AZFc region, was identified (Skaletsky *et al.*, 2003). PAR1 and PAR2 indicate the pseudoautosomal regions of the human Y chromosome at the tip of its short arm and long arm, respectively.

Human Spermatogoniogenesis During Embryogenesis

Human primordial germ cells (PGC) derived from the epiblast are first observed in the yolk sac close to the hindgut and allantois region by day 21–26 postconception (pc) (Politzer, 1933; Witschi, 1948). During the fifth

week of pregnancy, they migrate to the genital ridges, which then differentiate into an ovary or testis between day 36 and day 42 pc. PGC proliferation and migration to the genital ridge is controlled by multiple growth factors as well as by cell–cell interactions (De Felici *et al.*, 2004), especially to the surrounding supporting cell lineage, the Sertoli cells (McLaren, 1991). Among these are probably the c-kit/steel factor complex and TIAR, an RNA-binding protein of the RRM class (Beck *et al.*, 1998). Multiplying prospermatogonia develop from the PGC in the sex cords between week 8–22 of pregnancy (Hilscher and Engemann, 1992). These M-prospermatogonia are then replaced by transient (T)-prospermatogonia, also called fetal spermatogonia, later during embryogenesis (Wartenberg *et al.*, 1971). They are observed in the cords up to 6 months after birth. Only PGC and M-prospermatogonia stain with alkaline phosphatase (AP-positive cells). T-prospermatogonia complete the period of prespermatogoniogenesis and initiate spermatogoniogenesis after birth.

The Sertoli cell lineage is the first cell lineage showing a sex-specific differentiation during early embryogenesis (McLaren, 1991). It surrounds and supports the primordial germ cells, giving rise to pre-Sertoli cells in the male and follicle cells in the female. In response to a cascade of genetic activities initiated by the expression of *SRY* (sex-determining region gene on the Y chromosome; Koopman *et al.*, 1991), pre-Sertoli cells aggregate to form seminiferous cords containing the prospermatogonia and secrete the AMH (anti-Muellerian hormone) protein (Tran *et al.*, 1987). Pre-Sertoli cells are different from mature Sertoli cells in adults because of their capacity to proliferate and their lack of tight junctions. Pre-Sertoli cells block the proliferation of T-prospermatogonia and inhibit their meiosis (McLaren, 1994; Pelliniemi *et al.*, 1993). Consequently, in prospermatogonia, a long chromatin condensation period is observed (Luciani *et al.*, 1977). Since normal formation of testis tubules can take place in the absence of germ cells, but not in the absence of Sertoli cells, one reason for the occurrence of the Sertoli cell-only syndrome (SCO type I; according to Terada and Hatakeyama, 1991) is therefore most likely a fetal disruption of male germ cell development. An example is given by the molecular isolation of the mouse *Pog* (proliferation of germ cells) gene essential for primordial germ cell proliferation, causing the mouse *gcd* (germ cell-deficient) phenotype when disrupted (Agoulnik *et al.*, 2002). Severe distortion of the delicate

germ cell–Sertoli cell partnership modulating the survival of the embryonic germ cells can also cause the SCO type I syndrome (Kierszenbaum and Tres, 2001).

Human Spermatogoniogenesis After Birth

Immediately after birth, the seminiferous tubules are composed by T-prospermatogonia, spermatogonia, and Sertoli cells. Human spermatogonia are of the so-called A-pale and A-dark types. Ap spermatogonia display an excentrically located nucleus and homogeneously distributed chromatin. Ad spermatogonia can be distinguished by a characteristically lighter zone located in the middle of the nucleus (Hadziselimovic, 1977). The main morphological features used in distinguishing the different spermatogonia types at the level of the light microscope are the shape and staining characteristics of the nucleus, the placement of the nucleolus, and the presence or absence of glycogen in the cytoplasm [stained by periodic acid Schiff (PAS) reaction]. So, Ad spermatogonia have a dark karyoplasm with a typical pale hollow structure in the middle, whereas Ap spermatogonia are only stained weakly (i.e. pale). In young adults, a third type A spermatogonia — A long (AL) — was described by Rowley *et al.* (1971). AL spermatogonia are very flat, with the largest contact to the basal lamina. In the electron microscope, Schulze (1978) additionally observed an A cloudy type of spermatogonia, recognized later as DNA-synthesizing spermatogonia. The most comprehensive analysis of spermatogonias in adult testis was performed by Hilscher (1979), who studied a complete series of 250 semithin sections for the following parameters: shape of the nucleus, arrangements of nucleoli, retention of dyes in the karyoplasm and cytoplasm, cytoplasmatic structure, form of attachment to the basement membrane, and cluster sizes of the same and different spermatogonia types. In this way, Hilscher (1979) was able to distinguish 13 phenotypes of spermatogonia. Pale spermatogonia with light, absolutely homogeneous karyoplasm with or without large contact to the basal membrane (Ap or AL) were found to be the only cell types grouped in only small clusters. The size of the clusters increased with the degree of the spermatogonia differentiation process.

B spermatogonia, occurring at the age of 4 years, are smaller and rounder than the A-type from which they develop. Simultaneously with

the appearance of B spermatogonia and spermatocytes, Sertoli cells are found in increasing numbers. Interestingly, a marked germ cell proliferation, with the first germ cells differentiating to spermatocytes and even spermatids, can be observed at the end of infancy (about 3–4 years of age) and at 8–9 years of age (Mancini *et al.*, 1960). This has been explained as two natural (although premature) attempts to promote spermatogenesis, giving rise to spermatocytes or even spermatids in some tubuli, but never complete spermatogenesis. Different Sertoli cell types (Sa and Sb; according to Hadziselimovic, 1977) probably exercise a regulating effect on these germ cell proliferation and premature differentiation processes by means of immediate cellular contacts and direct substantial influence (Wartenberg, 1989). Early male germ cell development ends with the differentiation of A and B spermatogonia to spermatocytes, spermatids, and mature spermatozoa at puberty.

Genomic Structure of the AZFa Locus in Proximal Yq11

The genomic extension of the AZFa deletion interval in proximal Yq11 has been estimated by extensive breakpoint mapping experiments in the Y chromosome of men with the SCO syndrome. It seems to be mainly caused by an intrachromosomal recombination event of two homologous endogenous retroviral sequence blocks (HERV15yq1 and HERV15yq2), eventually deleting their intervening sequence of 792 kb (Fig. 2) (Blanco *et al.*, 2000; Kamp *et al.*, 2000; Sun *et al.*, 2000). The putative recombination sites in the fused HERV15yq1/HERV15yq2 sequence structure have been mapped to two identical sequence domains: ID1, a sequence of 1278 nt in HERV15yq1; and ID2, a sequence of 1690 nt in HERV15yq2 (Kamp *et al.*, 2001). Interestingly, HERV15yq2 contains a polymorphic 2-kb long truncated LINE element of the L1PA4 family that was recognized as the molecular origin of the well-known DYS11–12f2 restriction fragment length polymorphism distinguishing different Y chromosomal haplogroups (Casanova *et al.*, 1985). Its deletion was found to be associated with two distinct Y lineages (Blanco *et al.*, 2000). Based on the schematic phylogenetic tree of 153 binary Y chromosomal haplogroups established by The Y Chromosome Consortium (YCC, 2002), these two Y lineages should be linked to Y haplogroups D2* and J* (Vogt, 2005b). Since

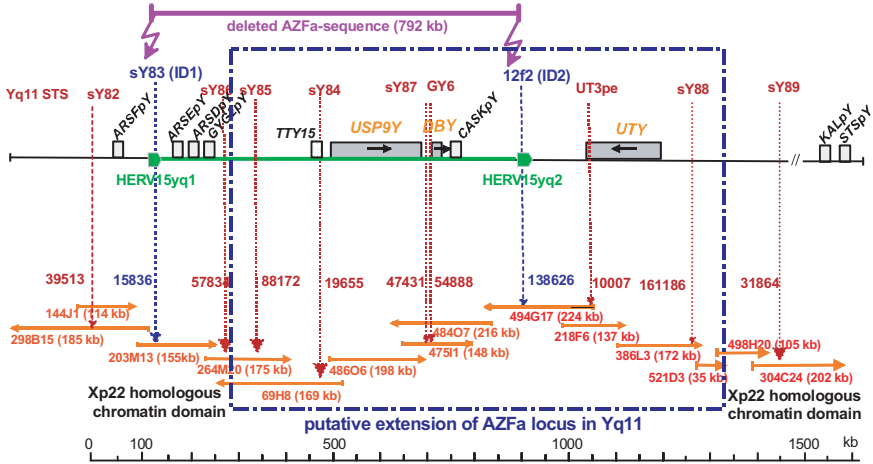

Fig. 2. Schematic view of the BAC contig in proximal Yq11, including the AZFa deletion interval and the putative extension of the conserved AZFa locus structure. Molecular data for drawing the extension and overlap of BAC clones and for marking the location of the linked STS markers were extracted from the NCBI GenBank (www.ncbi.nlm.nih.gov/GenBank) and Ensembl (www.ensembl.org) databases, respectively. White boxes mark the location of the seven pseudogenes (black letters), and gray-colored boxes the location of the three functional Y genes (orange letters) in this BAC contig. The extension of the AZFa sequence deleted in men with the complete SCO syndrome is given, with 792 kb bordered by the two homologous HERV15yq1 and HERV15yq2 elements (green-colored). The AZFa sequence is deleted by recombination at one of the HERV15yq1/q2 identical sequence blocks marked ID1 and ID2, and is distinguished by the presence and absence of sY83 (ID1) or 12f2 (ID2), respectively (blue-colored STS markers). The putative borderlines of the Xp22 homologous chromatin domains proximal and distal to the proposed AZFa chromatin unit have been estimated by *in silico* BLAST alignment analyses between X and Y chromosomal BAC clones of both genomic sequence regions, and by the results of the FISH experiments of Wimmer *et al.* (2002). The “//” lines mark the interruption of the gene map in order to also include the more distally located *KalpY* and *STSpY* pseudogenes on the map of this figure. For further description, see text.

the 2-kb-long DYS11–12f2 deletion would result in a significantly longer HERV15yq2 sequence domain identical to HERV15yq1 (6 kb vs. 1.6 kb), it can be assumed that men with a Y chromosome of haplogroup D2* or J* might have an increased intrachromosomal recombination rate for the HERV15yq1/yq2 sequence blocks. This might then also increase the rate of AZFa deletions in the Y chromosome of these populations.

Duplications of the HERV15yq1/2-bordered intervening sequence domain (i.e. duplications of the AZFa deletion interval) have been found in

the Y chromosomal haplogroup R1b6 (Bosch and Jobling, 2003). Since this Y clade is present in the Iberian Peninsula, with more than 8%, these AZFa duplications are most likely not associated with male infertility (Bosch *et al.*, 2002).

There is strong evidence that the genomic DNA sequence of the AZFa locus extends beyond the AZFa deletion interval in proximal Yq11. Considering the genomic Y sequence now published by Skaletsky *et al.* (2003), the DNA sequence in this Y region belongs to the X-degenerated Y sequence class. This means being diverged from the homologous sequence region of the X chromosome some million years ago, and having now evolved to a divergent Y sequence domain with a Y-specific sequence organization.

The ancient identical genomic structures of the X and Y chromosomes have most likely diverged along four distinct evolutionary strata, probably due to four major inversion events on the mammalian Y chromosome during mammalian evolution (Lahn and Page, 1999). At least one of these Y inversions has reduced the ancient large PAR (pseudoautosomal region) on the short arm of both sex chromosomes, and has transposed the evolutionary ancestor of the genomic region (including the AZFa sequence and its gene content) from distal Yp to proximal Yq11. This inversion event becomes visible when using PAC clones from proximal Yq11 in FISH (fluorescence *in situ* hybridization) experiments on normal human metaphase chromosomes (Wimmer *et al.*, 2002). These experiments revealed a distinct homology of these PACs to the distal part of the short arm of the X chromosome (Xp22.3). Surprisingly, however, all PACs located in the genomic sequence of the AZFa deletion interval, and some PACs mapped distal to HERV15yq2 and containing the *UTY* (ubiquitous testis Y) gene, failed to cross-hybridize to any site of the X chromosome (Wimmer *et al.*, 2002). This strongly suggests that the present X–Y homologous sequence block in proximal Yq11 is composed of two distinct chromatin domains: One is located proximal and distal to the AZFa deletion interval and to the *UTY* gene, and still has a high sequence homology to Xp22.3 as visible by the homologous FISH signals (Wimmer *et al.*, 2002). This splitted chromatin domain in proximal Yq11 is related to the most recently diverged X chromosomal strata group 4 (Lahn and Page, 1999). The second X–Y sequence block with the more divergent sequence domain contains the genomic sequence of the AZFa deletion interval and the *UTY* gene. According to Lahn and Page (1999), it should represent the evolutionarily older X chromosomal strata group 3.

Considering the gene content of the BAC contig established in proximal Yq11 including the AZFa deletion interval (Fig. 2), there are seven pseudogenes or encoding nonfunctional truncated proteins — *ARSFpY*, *ARSEpY*, *ARSDpY*, *GYG2pY*, *CASKpY*, *KALpY*, and *STSpY* — with their functional homologs in Xp22, and three functional protein-encoding Y genes — *USP9Y*, *DBY*, and *UTY* — with their functional homologs (*USP9X*, *DBX*, and *UTX*) in Xp11.4. This suggests a selective functional and male-specific pressure on the genomic Y sequence underlying the *USP9Y*, *DBY*, and *UTY* genes; and implies that not only the Y genes in the AZFa deletion interval (*USP9Y* and *DBY*), but also the *UTY* gene belong to this genetically defined male-specific functional AZFa spermatogenesis locus. The structural synteny of the same three AZFa genes is conserved on the porcine, cat, and mouse Y chromosome (Murphy *et al.*, 1999; Quilter *et al.*, 2002), and on the short arm of chromosome 5 of marsupials (Waters *et al.*, 2001). We therefore assume that *USP9Y*, *DBY*, and *UTY* are embedded in a unique functional AZFa chromatin unit conserved before mammalian radiation.

The Xp11–Xp22 border segments were *in silico* mapped proximal between STS markers sY86 and sY85 in BAC 264M20, and distal between STS markers sY88 and sY89 crossing the BACs 386L3 and 498H20, respectively (Fig. 2). The proximal AZFa borderline is distal to the *GYG2pY* pseudogene and 5' upstream of the *USP9Y* gene in BAC 264M20. The *TTY15* (testis-specific transcript Y 15) gene upstream of the *USP9Y* gene — also designated earlier as *AZFaT1* or *Phex152* transcript (Vogt, 2005a) — is, according to Skaletsky *et al.* (2003), one of the 23 nonfunctional Y genes because it is without a significant open reading frame. The distal AZFa borderline is distal to the *UTY* gene and proximal to the *KALpY* pseudogene in BAC 304C24. In comparison with the extension of the AZFa deletion interval, the supposed functional AZFa chromatin domain should then shift about 200 kb distal to the proximal AZFa deletion breakpoint in HERV15yq1, and extends about 400 kb downstream of HERV15yq2 in proximal Yq11 including completely the *UTY* gene (Fig. 2). From the sequence position of the STSs sY85 and sY89 (13.948.594 and 15.097.387), its molecular extension is estimated to be 1.15 Mb.

Today, it is known that the proteins encoded by the AZFa Y genes are functionally homologous to the proteins encoded by their X homologs. This raises the question why *USP9X* and *DBX* proteins are then not able

to compensate for the deletion of the USP9Y and DBY proteins in men with an AZFa deletion. If the X homologs are functioning in the male germ line, one explanation would be that both AZFa Y proteins form some functional complexes with the proteins of their X homologs in the male germ line; another explanation would be that the Y copy has a different role in spermatogenesis not provided by the X copy. In the following paragraphs, we would like to give a first answer to this question for each AZFa gene separately, thereby also including a description of the germ line function of their orthologs in other eukaryotes (especially in nonhuman mammals).

Structure and Function of the *USP9Y* Gene and Its Functional Homologs

The *USP9Y* gene, earlier also called the *DFFRY* (*Drosophila* fat facet receptor Y) gene (Brown *et al.*, 1998), encodes a ubiquitin-specific protease, i.e. it is a member of a gene family encoding deubiquitinating enzymes. These are involved in cellular protein metabolism, controlling their stability by binding specifically to ubiquitin–protein conjugates hydrolyzing their ubiquitin peptide chains at the carboxy terminus (D’Andrea and Pellman, 1998). Since only ubiquitin-conjugated proteins are degraded by the cellular proteasome complex, deubiquitination will increase their cellular stability. It is instructive to compare this protein ubiquitination/deubiquitination cycle process with the protein phosphorylation/dephosphorylation cycle process controlled by the counterbalancing action of protein kinases and phosphatases (Tonks and Neel, 1996). Like phosphorylation, protein ubiquitination is controlled by the coordinate action of multiple ubiquitin-conjugating enzymes and deubiquitinating enzymes.

There are six conserved regions (DH-I to DH-VI) in each ubiquitin processing enzyme, the prototype of which is the DUB1 protein (Zhu *et al.*, 1996).

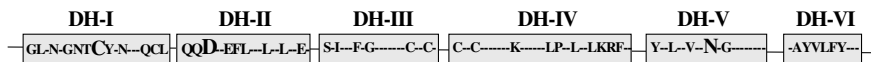

DH-I surrounds the catalytically functional conserved cysteine residue required in all ubiquitin-specific thiol proteases. DH-II contains the functional conserved aspartic acid, and DH-V the functional conserved histidine

residue. The catalytic triad of amino acids (see larger letters in schematic drawing) and the highly conserved structure of the core peptide with the six DH domains are essential for the enzymatic deubiquitination reaction of all DUB1-related proteins. This peptide core usually contains 300 to 500 amino acids. The putative enzymatic protease activity of *USP9Y* and its X chromosomal mouse homolog, *Usp9x*, has been experimentally analyzed by Lee *et al.* (2003). Accordingly, we have mapped the DUB1-related peptide core (DH-I to DH-VI) in the *USP9X* and *USP9Y* proteins of man and mouse between amino acid positions 1558 and 1956 encompassing 398 amino acids (Fig. 3). This peptide region is encoded by *USPX* exon 30 to exon 34, which corresponds to exons 32–36 of the *USP9Y* gene.

Outside the conserved core domain, the sequence of the deubiquitinating enzymes is highly variable in size and sequence, ranging between 526 amino acids for DUB1 and 2691 amino acids for the Faf protein (D'Andrea and Pellman, 1998). This suggests that the lengths of the N-terminal and C-terminal extensions from the core domain have a role in determining substrate specificity and cellular localization of the different ubiquitin proteases. Accordingly, functional subfamilies should exist with comparable length and significant conservation of amino acid blocks not only in the DUB1-related core domain (DH-I–VI), but also along the complete protein sequence.

The founding member of the *USP9Y/USP9X* ubiquitin protease subfamily, present with two homologous gene copies on the X and Y chromosomes of mouse and man (*Usp9x/Usp9y* and *USP9Y/USP9X*), is the *Drosophila* Faf protein encoded by the fat facets (*Faf*) gene and expressed with a high tissue specificity. The *Drosophila* *Faf* gene expression in the germ line is dependent on the function of *oskar*, a key factor for pole cell determination (Fischer-Vize *et al.*, 1992). This suggests a role for *Faf* in early embryonic germ cell development. Accordingly, expression of the homologous mouse *Usp9x* gene (sometimes also called *Fam*, fat facets in mouse) was found in the primordial germ cells (PGCs) at 10.5 days postcoitum (dpc) (Noma *et al.*, 2002). *Usp9x* expression then became enhanced in both sexes in PGCs at 11.5–13.5 dpc, which is just the time when the testis becomes morphologically distinct and fetal Leydig cells appear in the developing interstitium. Considering the overall conservation of the mouse and human *Usp9x*–*USP9X* protein sequence (>97% identical), it can be assumed that

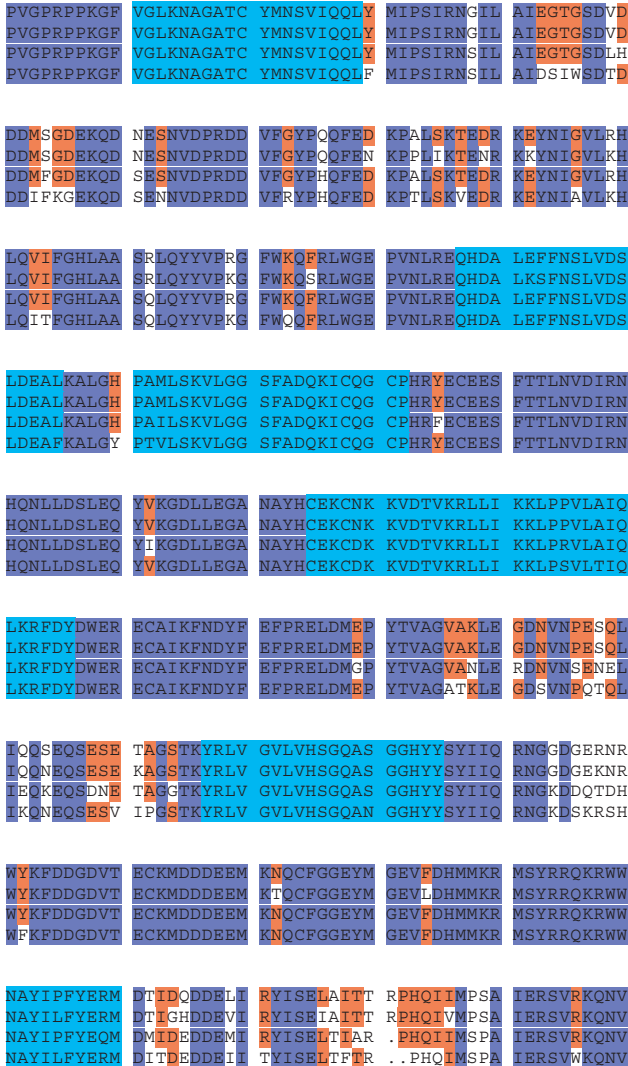

Fig. 3. Comparison of the catalytically functional DUB1-related peptide core (DH-I to DH-VI; light blue-green boxes from 5' to 3' end) in the USP9X and USP9Y proteins of man (first and third rows) and mouse (second and fourth rows). Blue-colored peptide domains are completely conserved in the human and mouse USP9Y families. Red-colored peptide domains are conserved in three of the four proteins. This peptide region is encoded by *USPX* exon 30 to exon 34 (corresponding to exons 32–36 of the *USP9Y* gene) and includes amino acids 1558–1956, thus encompassing 398 amino acids. The conserved functional triad — cysteine, aspartic acid, and histidine — is located in DH-I, DH-II, and DH-V, respectively. For further discussion, see text.

the human *USP9X* gene has a similar expression profile in the early germ cell lineage. Interestingly, this germ line function may be highly conserved, since the mouse *Usp9x* gene is able to functionally replace *Faf* in *Drosophila* embryos (Chen et al., 2000).

Besides their involvement in PGCs, *USP9X* and *Usp9x* (like *Faf*) are also functionally involved in the embryonic differentiation process of female germ cells. *Faf* mutations in *Drosophila* cause an abnormal oocyte content and also interfere with the capability of the fertilized egg to undergo normal embryogenesis (Fischer-Vize et al., 1992). This suggests a function of this gene in embryo development before implantation. Accordingly, it has recently been shown that its mouse homolog *Usp9x* is required for the development of the embryo to the blastocyst stage (Pantaleon et al., 2001). The loss of *Usp9x* expression resulted in two physiological effects, namely, a decrease in the embryonic cleavage rate and an inhibition of cell-adhesive events. Interestingly, depletion of the *Usp9x* protein was mirrored by the loss of β -catenin localized to similar sites of cell–cell contacts, therefore suggesting that the pool of β -catenin is stabilized in these cells by deubiquitinylation through *Usp9x* proteins (Pantaleon et al., 2001). Expression of the human *USP9X* gene in embryonic follicle cells and fertilized oocytes during the preimplantation phase has not yet been shown; but if present, its dysfunction might contribute to the severe reduction of oocytes shown in females with Turner syndrome, eventually leading to the degeneration of the developing ovary into a streak gonad (Cockwell et al., 1991) and to the disruption of early human embryonic development before the implantation phase.

In contrast to this, the function of the mouse and human Y homologs, *Usp9y* and *USP9Y*, seems to be expressed at a different developmental phase and restricted to the male germ line. Deletion of the *Usp9y* gene in mice (in the context of deletion of the large *Sxr^b* interval in *Yp*; Sutcliffe and Burgoyne, 1989) only causes a male germ line defect. Similarly, deletion or disruption of the *USP9Y* gene in humans only results in spermatid arrest (Qureshi et al., 1996; Sun et al., 1999). This suggests that after the evolutionary diversification of the ancient homologous X–Y region containing the *USP9X–USP9Y* gene pair, the Y gene in mammals has adopted a novel and restricted spermatogenic function (neofunctionalization). Accordingly, the mouse *Usp9y* gene has a restricted expression pattern mainly detectable

only in the testis, although reduced expression levels were initially also observed in the brain, epididymis, vas deferens, eye, and heart (Brown *et al.*, 1998).

Interestingly, in testis tissue, *Usp9y* expression was first found after birth from 14 dpc to adulthood in A and B spermatogonia (Brown *et al.*, 1998), but not in the primordial germ cells as found for *Usp9x* (Noma *et al.*, 2002). This supports the assumption of a neofunctionalization of the Y gene being expressed in the mouse male germ line at a phase distinct from that of *Usp9x*. Comparison of the amino acid sequences of the human USP9X and mouse *Usp9x* proteins — being 97% identical — with those of their Y homologs USP9Y and *Usp9y* — being both only ~85% identical to their X homologs — also suggests that the Y gene-encoded proteins might have a different germ line function, probably expressed by binding to different functional interaction partners in the different germ cells.

Despite the known restricted functional pattern of the *Drosophila* Faf and mouse Fam (*Usp9x*) proteins, the human *USP9Y* and *USP9X* genes were found to be expressed in each tissue analyzed (Jones *et al.*, 1996; Lahn and Page, 1997). A major question of our current research is therefore to reveal putative different transcriptional and translational control mechanisms of the human *USP9Y* gene in the male germ line that would control the expression of the USP9Y protein being expected predominantly in spermatids, since their deletion was found to be associated with a postmeiotic disruption phase of male spermatogenesis (Qureshi *et al.*, 1996; Sun *et al.*, 1999).

The mouse *Usp9y* gene promoter seems to be functionally active only in testis; more specifically, only in the germ cell-derived GCs-spd(ts) cell line (Hall *et al.*, 2003). This cell line was derived from an immortalized premeiotic spermatocyte that could be induced by temperature shift to enter meiosis (Hofmann *et al.*, 2004). However, subsequent analysis has shown that these cells have lost their ability to undergo meiosis; instead, they are arrested at a premeiotic stage (Wolkowicz *et al.*, 1996). Nevertheless, the first mapping experiments of the mouse *Usp9y* promoter region in luciferase reporter assays have pointed to a core promoter supposed to be functional also in nontestis cells (Hall *et al.*, 2003). The testis-specific expression of the mouse *Usp9y* gene must then be controlled by testis-specific transactors binding distal to the *Usp9y* promoter core domain, thereby functional

as testis-specific enhancer modules. Preliminary results of our laboratory study indicate that expression of the human *USP9Y* gene in the male germ line might be controlled by a similar mechanism, however, starting from a distinct promoter region not identified in the mouse genes and also not in the 5' upstream sequence of the human *USP9X* gene (Zimmer and Vogt, in preparation).

In summary, we can assume that the expression of the Usp9y/*USP9Y* and Usp9x/*USP9X* deubiquitinating enzymes in the germ lines of mouse and man contributes to the enrichment of some unknown germ line proteins expressed in primordial germ cells (PGC), and in early oogonia or spermatogonia (interacting with Usp9x/*USP9X*) or in spermatids (interacting with Usp9y/*USP9Y*), thereby increasing their stability.

Structure and Function of the *DBY* Gene and Its Functional Homologs

The human *DBX* gene was first described as the single-copy *DDX12* gene (Chung *et al.*, 1995) and mapped to the X chromosome (Park *et al.*, 1998), but was then recognized to have a Y chromosomal homolog in proximal Yq11 (*DBY*; Lahn and Page, 1997). Consequently, *DDX12* was renamed as *DBX* (Lahn and Page, 1997). Today, all human DEAD-box RNA helicases have been coded with consecutive numbers (#), and the same *DDX#* symbol gives *DBX* and *DBY* the codes *DDX3X* and *DDX3Y*, respectively (Abdelhaleem *et al.*, 2003). This nomenclature does not distinguish the functionally different subfamilies of the heterogeneous family of DEAD-box RNA helicases that exist in all eukaryotic genomes, including humans (Schmid and Linder, 1992). Although all members of the DEAD-box family contain eight (I–VIII) highly conserved peptide domains essential for the ATP-driven RNA duplex unwinding process (Rocak and Linder, 2004), comparison of the peptide sequence between and beyond these revealed a distinct sequence divergence between the DEAD-box RNA helicases of four subfamilies — *DBY*-, *EIF4*-, *P68/P72*-, and *VASA* — and a strong sequence relationship between the members of each subfamily. From these sequence alignment analyses, only the testis-specific expressed *VASA* gene was recognized to be probably functionally related to the *DBX/DBY* gene subfamily.

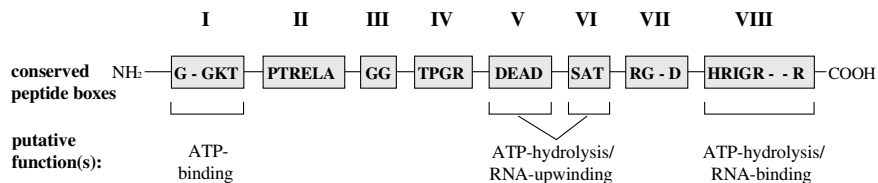

A systematic comparative analysis of VASA and DBX protein sequences in different metazoa, including the low metazoans (sponge, hydra, and planaria), suggests that this functional relation might indeed exist and that the ancient *vasa* gene was derived from the ancient *Dbx/PL10* gene (Mochizuki *et al.*, 2001). This conclusion was drawn from the result that only *PL10* gene-related sequences were identified in plants and that only the *PL10*-related genes have a wide tissue expression; whereas expression of the *vasa*-related genes has always been restricted to the germ line already in hydra, like in man (Castrillon *et al.*, 2000). It was therefore concluded that the VASA protein has evolved from the *PL10*-related protein to extend or support a specific germ line function. Indeed, in the embryonic germ lineage of *Drosophila*, colocalization of VASA and the *PL10*-related protein Belle in the germ line plasm suggests a germ line function of both RNA helicases (Johnstone *et al.*, 2005). It might thus be speculated that the mouse and human Y homologs (*Dby/DBY*) of the X chromosomal *Dbx/DBX* gene have also maintained their function because of an extended germ line function of the X gene in mammals. The X–Y mammalian sex chromosome structures diverged about 100 million years ago before mammalian radiation (see above). Usually, along such a long time interval, Y gene copies would have diverged to nonfunctional pseudogenes, as shown for multiple other X–Y gene pairs that evolved at a similar time (Lahn and Page, 1999).

On the other hand, the mammalian X gene copy is expressed at a double dose in mice and in human females because it does not underlie the common mammalian X chromosomal inactivation mechanism (Lahn *et al.*, 2001). Consequently, transcription of the *Dby/DBY* gene in mouse and man has been found in all tissues analyzed, and a function of *DBY* in non-germ line cells has also been suspected (Lahn and Page, 1997). Indeed, both proteins shuttle similarly between the nucleus and the cytoplasm using the CRM1 receptor pathway (Fornerod *et al.*, 1997), and the nuclear function of the *DBY* and *DBX* proteins seems to be interchangeable in the BHK21 hamster cell line (Sekiguchi *et al.*, 2004). The human *DBY* gene rescued

the temperature-sensitive *Dbx* mutant ET24 of this cell line by expression in the G1 phase of the cell cycle. Similarly, in yeast expression, *DBX* or *DBY* was able to rescue the translation initiation function of the structurally homologous *Ded1p* RNA helicase (Chuang *et al.*, 1997). *Ded1p* is involved in the 40S ribosome-scanning mechanism of translation initiation in yeast cells (Berthelot *et al.*, 2004). This function can also be fulfilled by the *Ded1p* mouse homolog *DIPas1*, a functional retrogene of *Dbx*, and by its *Drosophila* homolog Belle (Mamiya and Worman, 1999; Johnstone *et al.*, 2005). RNA helicases of the *DBX/DBY* subfamily are therefore assumed to be functionally involved in the nucleus and the cytoplasm, shuttling between both cell compartments during development. This has been experimentally proven for the homologous An3 protein in *Xenopus* that is expressed during oogenesis and embryogenesis (Longo *et al.*, 1996), and with a restricted pattern in the brain and the kidney at later developmental stages (Sowden *et al.*, 1995).

In humans, the first expression analysis indicated an ubiquitous transcription of the *DBY* and *DBX* genes at similar levels in all tissues analyzed, although a class of shorter transcripts was observed specifically in the RNA pool of testis tissue (Lahn and Page, 1997). Using a more specific *DBY* hybridization probe, large quantitative variability of *DBY* expression was observed in different human tissues; and a predominant expression of *DBY* transcripts was found in testis tissue, including at least five different RNA species with lengths of 5.2 kb, 3.9 kb, 3.2 kb, 2.9 kb, and 2.7 kb (Ditton *et al.*, 2004). Only the 5.2 kb *DBY* transcript was also found in the other tissues analyzed, although in lower amounts. It could therefore be concluded that there is a testis-specific transcriptional control for expression of the *DBY* gene in humans, resulting in a number of shorter transcripts and a predominant expression of all transcript lengths only in testis tissue. Analyzing the putative molecular origin(s) of the *DBY* transcript variability by 5' and 3' RACE experiments with testis poly(A) RNA, it could be revealed that *DBY* primary transcripts are processed differentially only in testis tissue (Vogt *et al.*, in prep.). Since *DBY* transcripts are translated only in testis tissue (Ditton *et al.*, 2004), it is most likely that the testis-specific *DBY* transcript processing is part of the translational control of these transcripts and that a function of the *DBY* gene outside the male germ line is questionable.

With the aid of two polyclonal antisera, recognizing specifically only DBX protein (DBX-10 antiserum) or DBY protein (DBY-10 antiserum) on Western blots, it was possible to distinguish the expression phase of DBY and DBX proteins in testicular tissue sections (Ditton *et al.*, 2004). The DBY-specific antiserum predominantly stained the cytoplasm of spermatogonia, suggesting a cytoplasmic function for the DBY RNA helicase specifically in these premeiotic germ cells. The DBX-specific antiserum stained germ cells of a different spermatogenic phase, namely the post-meiotic spermatids (Fig. 4). These results explain why the lack of DBY protein in men with *DBY*- or complete AZFa-deletion cannot be rescued by expression of the DBX protein. Despite their high sequence and therefore also functional homology, the DBY and DBX RNA helicases serve their cellular function during different phases of the human male germ cell differentiation process.

Most interesting is the observation that for the *DBY* mouse homolog, *Dby*, there is no evidence for its requirement in the mouse male germ line

DBX and DBY proteins are expressed in different male germ cells

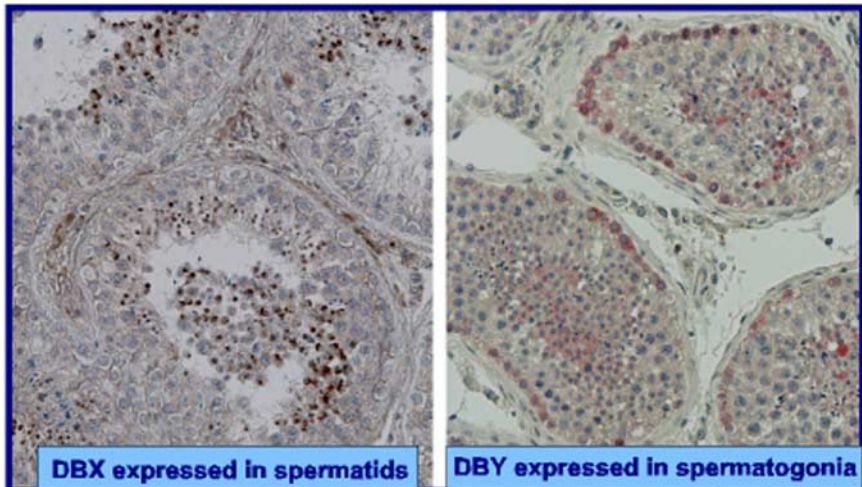

Fig. 4. Immunohistochemical staining of the location of DBX and DBY proteins in human testicular tissue sections with two polyclonal antisera specific for DBX (DBX-10 antiserum) and DBY (DBY-10 antiserum). DBX protein is predominantly expressed in spermatids; DBY protein, in spermatogonia. For further description and discussion of these results, see Ditton *et al.* (2004).

(Mazeyrat *et al.*, 2001). The *Dby* gene has been mapped to the Sxr^b interval of the short arm of the mouse Y chromosome, and its transcription was found in all tissues analyzed (Mazeyrat *et al.*, 1998). From the viewpoint of evolution, the Sxr^b interval on the short arm of the mouse Y chromosome has been considered to be functionally equivalent to the human AZFa interval because, after Sxr^b deletion, spermatogonia proliferation was disrupted in the mouse male germ line, as was found after AZFa deletion in humans (Mazeyrat *et al.*, 1998). The associated functional mouse spermatogenesis locus was therefore called the spermatogonia proliferation Y (*Spy*) locus (Sutcliffe and Burgoyne, 1989). Indeed, the gene content of both spermatogenesis loci, *Spy* and *AZFa*, seemed to be comparable: both contain the syntenic triplet, *Usp9y*, *Dby*, and *Uty*, which is also structurally conserved on the Y chromosome of cats and pigs (Murphy *et al.*, 1999; Quilter *et al.*, 2002). However, other Y genes which also mapped to the mouse *Spy* locus — *Eif2-s3y*, *Smcy*, *Ube1y*, and *Zfy* — were not found in the human *AZFa* locus, suggesting that the functional conservation of both spermatogenesis loci might be limited. Accordingly, expression not of the *Dby* RNA helicase, but of the *Eif2-s3y* RNA helicase subunit was able to restore the normal spermatogonial proliferation process in mouse strains with *Spy* deletion (Mazeyrat *et al.*, 2001).

A different spermatogenesis function of the human *DBY* gene and its mouse homolog can probably be explained by the presence of an autosomal retrogene of the mouse *Dbx* gene (*PL10*, *DIPas1*) that is expressed only in testis tissue (Leroy *et al.*, 1989; Session *et al.*, 2001) and is absent in the human genome (Kim *et al.*, 2001). The creation of intronless retrogenes by retroposition of transcripts from genes located on the sex chromosomes seems to be a common mechanism for male germ line genes when they have a function at meiosis (Wang, 2004). Accordingly, the *DIPas1* gene, which has been mapped on mouse chromosome 1, expresses its protein predominantly in the nuclei of spermatocytes undergoing meiosis (Session *et al.*, 2001). At this developmental germ cell phase, transcription of the mouse *Dby* and *Dbx* genes is repressed because of the meiotic sex chromosome inactivation (MSCI) mechanism and the formation of the sex vesicle (Fernandez-Capetillo *et al.*, 2003). In mice, *DIPas1* might therefore have complemented or even taken over the spermatogenic *Dby* gene function. In humans, an autosomal functional *DBX* or *DBY* retrogene might not be

necessary, since the function of both proteins is restricted to the premeiotic (DBY protein) and postmeiotic (DBX protein) germ cell phases, respectively (Ditton *et al.*, 2004). Expression of the functionally related VASA RNA helicase in primary spermatocytes should then be sufficient for the cellular functions of this protein class. If this holds true, then we have to conclude that the evolutionary pressure on Y genes functional for spermatogenesis in mouse and man and mapped in the *Sxr^b* and *AZFa* regions, respectively, is different when considering the single genes and might be more comparable after setting the focus on the complete Y gene content of the *SpY* and *AZFa* loci, both of which are involved in the same genetic network controlling the proliferation of spermatogonia. The mouse *Eif2-s3y* gene might then be considered as the functional equivalent of the human *DBY* gene.

An intriguing speculation in this context might also be the assumption of some functional interactions between *DBY* and *DBX* transcripts (or proteins) in the male germ line constituting a haploinsufficient genotype and genetic dominance of the *DBY* locus, as similarly proposed by Wilkie (1994). This would help to explain the variability of testicular pathologies observed in some men with only *DBY* deletions (Foresta *et al.*, 2000). Indeed, a higher level of *DBY* transcripts than *DBX* transcripts was found in all tissues analyzed, especially in testis tissue where only *DBY* (not *DBX*) transcripts were prominent (Ditton *et al.*, 2004). Accordingly, we would expect a different transcription profile for the *DBX* gene in men with *DBY* deletions. It is also possible, however, that the variability of the testicular pathologies in men with *DBY* deletions could be due to a primarily postmeiotic spermatogenic disruption after *DBY* deletion, and that the SCO syndrome is due to secondary age-dependent defects like those described for patients with *AZFc* deletions (Vogt, 2005a). In mice, age-dependent defects eventually resulting in the SCO syndrome were described in the two mice strains *X0Sry/Eif2s3y* and *XSxr^b0/Eif2s3y*, which both lack the mouse *Dby* gene (Mazeyrat *et al.*, 2001).

Structure and Function of the *UTY* Gene and Its Functional Homologs

The *UTY* (ubiquitous transcribed Y) and *UTX* (ubiquitous transcribed X) genes are members of the tetratricopeptide repeat (TPR) protein family first

identified in proteins controlling mitosis (Lamb *et al.*, 1995). The TPR motif is a degenerate 34-amino acid repeat facilitating specific interactions with a partner protein or serving as a chaperone, thus functioning as a protein–protein interaction module in functionally unrelated proteins. It is often (but not always) found in tandem copies, with no preferential positioning along the primary sequence. Three-dimensional structural data have shown that a TPR motif contains two antiparallel alpha helices, such that tandem arrays of TPR motifs generate a right-handed helical structure with an amphipathic channel that can accommodate the complementary region of a target protein. Most TPR-containing proteins are associated with multiprotein complexes, and there is extensive evidence indicating that TPR motifs are important to the functioning of the cell cycle, transcription, and transport of protein complexes (Blatch and Laessle, 1999).

The UTY and UTX proteins contain eight TPR motifs in the N-terminal sequence region between amino acids 90 and 382 (Fig. 5). The highest sequence homology of these TPR motifs outside the eight TPR consensus residues was found to the N-terminal TPR motifs of the yeast glucose Ssn6p repressor protein, suggesting an involvement of UTY and UTX in transcriptional control processes (Greenfield *et al.*, 1996). Ssn6p is a nuclear phosphoprotein required for normal yeast growth, sporulation, and mating (Schultz *et al.*, 1990). Mammalian proteins related to Ssn6p interact with transcriptional repressors of the transducin-like enhancer of split (TLE) family, just like Ssn6p interacts with the repressor Tup1 in yeast (Keleher *et al.*, 1992). Thereby, Ssn6p functions as an adaptor to some sequence-specific DNA-binding proteins, inhibiting their usually active promoter function. Functional analysis of a putative interaction of UTY and UTX proteins with the TLE1 protein in yeast two-hybrid interaction studies revealed specific interaction complexes between the TPR motifs of UTX and UTY and the N-terminal half of TLE1 (Grbavec *et al.*, 1999). It can therefore be concluded that UTX and UTY proteins are functionally involved in transcriptional repression processes of some unknown human genes, the expression of which is controlled by specific DNA-binding proteins. To elucidate this function in the male germ line, the cellular localization of UTY and UTX transcripts and proteins in testicular tissue sections needs to be identified.

Expression analyses of the UTY mouse homolog *Uty* revealed transcripts in all fetal male tissues analyzed (11.5 dpc) including the gonads, male

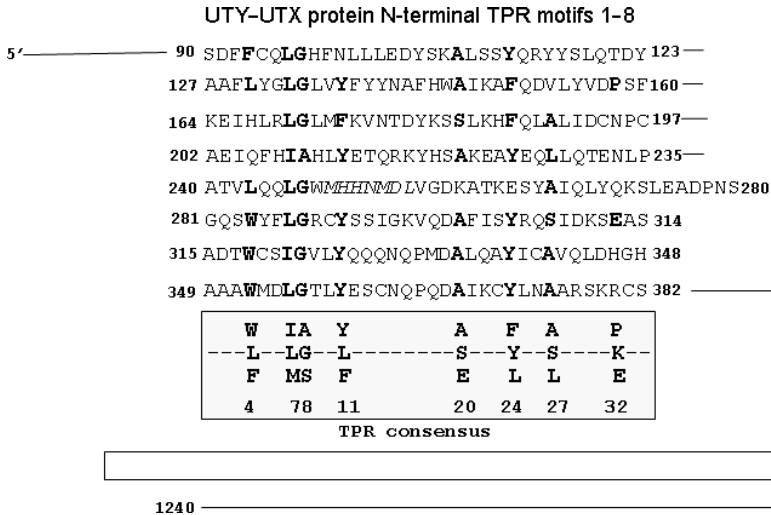

Fig. 5. Comparison and map of the tetratricopeptide repeat (TPR) sequence in the protein sequence of UTY and UTX. By sequence alignment with the 34 amino acids of the TPR consensus sequence as defined by Blatch and Laessle (1999), eight TPR motifs were identified in the N-terminal region of the UTY and UTX proteins between amino acids 90 and 382 (UTY), as indicated. This corresponds to amino acids 98 and 400 of the UTX protein. The TPR motif code is known to be somewhat degenerated and mainly conserved in positions 7, 8, 20, 24, and 27. This is also true for the UTY- and UTX-TPR motifs, and both are identical over the complete TPR sequence domain. Most interesting is the extension of the fifth repeat block to 41 amino acids, probably resulting in deviation from the consensus sequence at position 20. The same repeat extension was also found in the yeast TPR protein Ssn6p. The italic-written *MHHNMDL* peptide in this TPR domain encodes the H-YD^b epitope in the mouse Uty TPR domain (Greenfield *et al.*, 1996).

embryonic stem cells (ES), and blastocysts, but not in female embryos as expected for transcription of a Y gene (Greenfield *et al.*, 1996). Expression of *Uty* in mouse blastocysts and embryonic stem cells makes it a candidate gene for Gdy (growth and development locus on the Y), controlling the growth acceleration of XY male preimplantation embryos first described by Burgoyne (1993). Since expression analyses of the human *UTY* and *UTX* genes in different human tissues and cell lines by gene-copy-specific RT-PCR assays revealed an ubiquitous expression profile, there is no evidence for a specific male germ line function of the mouse or human *UTY/Uty* and *UTX/Utx* gene pairs, respectively. Exploring putative mutations of the human *UTY* gene by quantitative RT-PCR expression assays in leucocytes

and in testis tissue in a number of infertile men with different testicular pathologies was also not informative for a male germ line function of this *AZF α* gene. These negative results are probably due to being not yet able to focus on a more specific infertile patient subgroup.

In this context, it is interesting to note that the human UTY protein, like the mouse Uty protein, interacts with some gene products expressed in different classes of the large major histocompatibility (MHC) locus on the short arm of chromosome 6. Two of these HY antigens, HLA-B60 and HLA-B8, were recognized to be encoded by the human *UTY* gene (Vogt *et al.*, 2000a; Warren *et al.*, 2000); whereas the mouse Uty-encoded HY antigen H-Y-D^b is part of the extended fifth TPR repeat (Fig. 5), with the peptides of the human HY antigens being encoded proximal (HLA-B60: pos. 38–48 aa) and distal (HLA-B8: 566–573 aa) to the TPR sequence domain. The early embryogenesis expression of the mouse Uty gene can therefore also be considered as the expression of an early male-specific (i.e. HY antigen) cell marker, signaling the first steps of male-specific sexual and germ cell development. The influence of some HY antigens on human (and mouse) testicular organization and spermatogenesis has long been predicted, and the HY antigen locus in humans was mapped to the proximal region of the Yq euchromatin including *AZF α* and *AZF β* (O'Reilly *et al.*, 1992).

Accordingly, expression of specific HY antigens was also reported for the other *AZF α* proteins, *USP9Y* (HLA-A1; Vogt *et al.*, 2000b) and *DBY* (HLA-DQ5; Vogt *et al.*, 2002), and for the *SMCY* protein (Wang *et al.*, 1995) encoded in *AZF β* . This raises the possibility that expression of the HY antigens encoded by the three *AZF α* proteins are associated with early embryonic male somatic cell determination and differentiation processes, like the determination of the Sertoli cells or the spermatogonia stem cell population. HY antigen expression during early mouse embryogenesis at the eight-cell stage was also reported by Krco and Goldberg (1976), and it has been shown that HY antigens were indeed only secreted by Sertoli cells (Zenzes *et al.*, 1978). Accordingly, receptor proteins binding HY antigens were only found in the male gonad (Müller *et al.*, 1978). A morphogenetic function of distinct HY antigens expressed by one or all *AZF α* proteins (*USP9Y*, *DBY*, *UTY*) promoting the proliferation rate of male blastocysts, as proposed by Burgoyne (1993), is therefore an attractive speculation.

AZFa Genes and the Gonadoblastoma Y (GBY) Locus in Yq11

Molecular mapping studies in women with a disorder in their sexual development (DSD; gonadal dysgenesis) and with a Y chromosome in the karyotype of their leucocytes and/or gonad tissue samples (46,XY/46,XX and 46,XY/45,X0 mosaics) have pointed to a genomic region in proximal Yp and Yq expressing genes involved in the development of gonadoblastoma cells in these patients' gonad tissue (gonadoblastoma Y locus, GBY; Salo *et al.*, 1995; Tsuchiya *et al.*, 1995). From sequence analysis, it can be deduced that GBY should include the *TSPY* (testis-specific protein Y) gene; an X–Y homologous gene in Yp; the homeobox-containing *DUX* gene family proposed to be involved in male-specific growth control and mapped in proximal Yq near the centromere (Kirsch *et al.*, 2005); and the three X–Y homologous *AZFa* genes, *USP9Y*, *DBY*, and *UTY*. Additionally, some Y-specific LTRs (long terminal repeats) of the different HERVK (human endogenous retrovirus K) subfamilies in AZFa — like the *DYS11* locus (Kamp *et al.*, 2000) — may contribute to the expression of a gonadoblastoma cell, since HERV elements were found to be transcriptionally active in gonadoblastomas and derived germ cell tumors (Herbst *et al.*, 1999). In the literature, the occurrence of gonadoblastomas in 46,XY females with dysgenetic gonads is described with a risk of about 30% (Verp and Simpson, 1987). Complete removal of their gonads is therefore clinically advised before puberty.

Gonadal dysgenesis is the result of disruption of some genetic interaction(s) in the network controlling the signaling pathways that are superimposed on the transcriptional cascades essential for making a testis or an ovary (Ross and Capel, 2005). The occurrence of ambiguous genitalia developing already during early embryogenesis points to a delicate balance between the different signal pathways necessary for both sexual developments. Most female patients with a dysgenetic testis and a contralateral streak gonad have a 45,X/46,XY karyotype in their leucocytes. This suggests that gonadal dysgenesis can be caused by the dysfunction of some unknown genes on the sex chromosomes functionally downstream of the Y chromosomal *SRY* gene and expressed in fetal gonad or fetal germ cells. Expression of the *AZFa* genes at this stage is represented by the expression of their specific HY antigens, as discussed above. Since HY expression in female gonads was found as a putative risk factor for the

expression of gonadoblastomas and dysgerminomas in individuals with XY gonadal dysgenesis (Verp and Simpson, 1987), HY antigens expressed by the AZFa proteins might be causative agents for the development of these tumor cells.

The major *GBY* candidate gene might be, however, the *TSPY* gene mapped with multiple copies in proximal Yp and encoding a nuclear protein of the SET/NAP family, which is involved in the functional control of the G₂/M phase transition of the cell cycle (for more details, see chapter 4). The expression of TSPY proteins in gonadoblastoma cells was recently demonstrated (Schnieders *et al.*, 1996), and — in combination with the expression profile of the *OCT-3/4 (POU1)* gene — the potential progression of a gonadoblastoma cell to an invasive tumor cell (dysgerminoma, seminoma) was shown by appropriate immunohistochemical staining experiments (Kersemaekers *et al.*, 2005).

Outlook

The human species is not an experimental system. Consequently, knowledge of human spermatogenesis can usually be collected only from testis tissue samples, which are accessible for some medical reasons like after spontaneous or induced abortion events (fetal tissue samples), during surgical gonadal corrections at childhood, or in the adult during surgical treatments of testis tumors or of obstructions of the vas deferens inhibiting the ejaculation of mature sperms. Using these tissue samples for molecular genetic studies aimed to understand the basic mechanisms controlling human spermatogenesis would be, however, only meaningful if one is able to exclude any destructive effects on this cell differentiation process caused by the patient's disease. This is obviously only possible after the basic controlling mechanisms discussed above are known in detail.

The summary looks like a vicious circle, and one (most often used) possibility to escape it is to analyze testis tissue samples and spermatogenesis in an adequate animal as a model system. This has been done extensively in *Caenorhabditis elegans* (Ellis and Kimble, 1994), in *Drosophila* (Hennig, 1988; Hochstenbach and Hackstein, 2000), and in different mammals like rat and mouse (Burgoyne, 1998; Cooke and Saunders, 2002; Holdcraft and Braun, 2004; Matzuk and Lamb, 2002; see also chapter 1).

However, considering the fact that these animals have usually evolutionarily diverged from the human lineage millions of years ago, it is important to recognize that any extrapolation of the results obtained from animal model systems to humans may be a hazardous procedure and may not be justified, as shown here for the distinct expression of the *DBY* gene in mice and humans.

Acknowledgments

We thank our collaborators and teachers, Martin Bergmann, Werner and Barbara Hilscher, Walter Krause, Ewa Rajpert-De Meyts, Wolfgang Schulze, and Niels Skakkebaek, for their numerous valuable contributions and continuous support of our AZFa research project. Without their help, our basic understanding of the clinical etiology of the different testicular pathologies and their often nongenetic background in infertile men with AZFa deletions would have remained rather limited. Paul Burgoyne is thanked for the many fruitful discussions on the different functions of the mouse and human Y genes and their comparison. We are indebted to Christine Mahrla for her help in preparing the final version of this manuscript, and to Uli Müller for his support in the final figure design. Professor Thomas Strowitzki is thanked for his continuous support of the clinical part of our experimental AZFa research aims. The AZFa project is financially supported by grants from the *Deutsche Forschungsgemeinschaft* to PH Vogt (DFG: Vo403/11-6; Vo403/16-1).

References

- Abdelhaleem, M., Maltais, L., and Wain, H. (2003). The human DDX and DHX gene families of putative RNA helicases. *Genomics* **81**, 618–622.
- Agoulnik, A. I., Lu, B., Zhu, Q., Truong, C., Ty, M. T., Arango, N., Chada, K. K., and Bishop, C. E. (2002). A novel gene, Pog, is necessary for primordial germ cell proliferation in mouse and underlies the germ cell deficient mutation, gcd. *Hum Mol Genet* **11**, 3047–3053.
- Bardoni, B., Zuffardi, O., Guioli, S., Ballabio, A., Simi, P., Cavalli, P., Grimoldi, G., Fraccaro, M., and Camerino, G. (1991). A deletion map of the human Yq11 region: implications for the evolution of the Y chromosome and tentative mapping of a locus involved in spermatogenesis. *Genomics* **11**, 443–451.
- Beck, A. R., Miller, I. J., Anderson, P., and Streuli, M. (1998). RNA-binding protein TIAR is essential for primordial germ cell development. *Proc Natl Acad Sci U S A* **95**, 2331–2336.

- Berthelot, K., Muldoon, M., Rajkowitsch, M., Hughes, J., and McCarthy, J. E. (2004). Dynamics and processivity of 40S ribosome scanning on mRNA in yeast. *Mol Microbiol* **51**, 987–1001.
- Blagosklonova, O., Fellmann, F., Clavequin, M. C., Roux, C., and Bresson, J. L. (2000). AZFa deletion in Sertoli cell-only syndrome: a retrospective study. *Mol Hum Reprod* **6**, 795–799.
- Blanco, P., Shlumukova, M., Sargent, C. A., Jobling, M. A., Affara, N., and Hurles, M. E. (2000). Divergent outcomes of intrachromosomal recombination on the human Y chromosome: male infertility and recurrent polymorphism. *J Med Genet* **37**, 752–758.
- Blatch, G. L., and Laessle, M. (1999). The tetratricopeptide repeat: a structural motif mediating protein-protein interactions. *Bioessays* **21**, 932–939.
- Bosch, E., and Jobling, M. A. (2003). Duplications of the AZFa region of the human Y chromosome are mediated by homologous recombination between HERVs and are compatible with male fertility. *Hum Mol Genet* **12**, 341–347.
- Bosch, E., Lee, A. C., Calafell, F., Arroyo, E., Henneman, P., de Knijff, P., and Jobling, M. A. (2002). High resolution Y chromosome typing: 19 STRs amplified in three multiplex reactions. *Forensic Sci Int* **125**, 42–51.
- Brown, G. M., Furlong, R. A., Sargent, C. A., Erickson, R. P., Longepied, G., Mitchell, M., Jones, M. H., Hargreave, T. B., Cooke, H. J., and Affara, A. (1998). Characterisation of the coding sequence and fine mapping of the human *DFFRY* gene and comparative expression analysis and mapping to the *Sxr^b* interval of the mouse Y chromosome of the *Dffry* gene. *Hum Mol Genet* **7**, 97–107.
- Burgoyne, P. S. (1993). A Y-chromosomal effect on blastocyst cell number in mice. *Development* **11**, 341–345.
- Burgoyne, P. S. (1998). The mammalian Y chromosome: a new perspective. *Bioessays* **20**, 363–366.
- Casanova, M., Leroy, P., Boucekkin, C., Weissenbach, J., Bishop, C., Fellous, M., Purrello, M., Fiori, G., and Siniscalco, M. (1985). A human Y-linked DNA polymorphism and its potential for estimating genetic and evolutionary distance. *Science* **230**, 1403–1406.
- Castrillon, D. H., Quade, B. J., Wang, T. Y., Quigley, C., and Crum, C. P. (2000). The human VASA gene is specifically expressed in the germ cell lineage. *Proc Natl Acad Sci U S A* **97**, 9585–9590.
- Chen, X., Overstreet, E., Wood, S. A., and Fischer, J. A. (2000). On the conservation of function of the *Drosophila* fat facets deubiquitinating enzyme and Fam, its mouse homolog. *Dev Genes Evol* **210**, 603–610.
- Chuang, R. Y., Weaver, P. L., Liu, Z., and Chang, T. H. (1997). Requirement of the DEAD-box protein ded1p for messenger RNA translation. *Science* **275**, 1468–1471.
- Chung, J., Lee, S.-G., and Song, K. (1995). Identification of a human homolog of a putative RNA helicase gene (mDEAD3) expressed in mouse erythroid cells. *Korean J Biochem* **27**, 193–197.
- Cockwell, A., MacKenzie, M., Youings, S., and Jacobs, P. (1991). A cytogenetic and molecular study of a series of 45,X fetuses and their parents. *J Med Genet* **28**, 151–155.
- Cooke, H. J., and Saunders, P. T. (2002). Mouse models of male infertility. *Nat Rev Genet* **3**, 790–801.
- D'Andrea, A., and Pellman, D. (1998). Deubiquitinating enzymes: a new class of biological regulators. *Crit Rev Biochem Mol Biol* **33**, 337–352.

- De Felici, M., Scaldaferrri, M. L., Lobascio, M., Iona, S., Nazzicone, V., Klinger, F. G., and Farini, D. (2004). Experimental approaches to the study of primordial germ cell lineage and proliferation. *Hum Reprod Update* **10**, 197–206.
- Ditton, H. J., Zimmer, J., Kamp, C., Rajpert-De Meyts, E., and Vogt, P. H. (2004). The AZFa gene DBY (DDX3Y) is widely transcribed but the protein is limited to the male germ cells by translation control. *Hum Mol Genet* **13**, 2333–2341.
- Ellis, R. E., and Kimble, J. (1994). Control of germ cell differentiation in *Caenorhabditis elegans*. *Ciba Found Symp* **182**, 179–188.
- Ferguson-Smith, M. A., Affara, N. A., and Magenis, R. E. (1987). Ordering of Y-specific sequences by deletion mapping and analysis of X-Y interchange males and females. *Development* **101**(Suppl), 41–50.
- Fernandez-Capetillo, O., Mahadevaiah, K., Celeste, A., Romanienko, P. J., Camerino-Otero, R. D., Bonner, W. M., Manova, K., Burgoyne, P., and Nussenzweig, A. (2003). H2AX is required for chromatin remodeling and inactivation of sex chromosomes in male mouse meiosis. *Dev Cell* **4**, 497–508.
- Fischer-Vize, J. A., Rubin, G. M., and Lehmann, R. (1992). The fat facets gene is required for *Drosophila* eye and embryo development. *Development* **116**, 985–1000.
- Foot, S., Vollrath, D., Hilton, A., and Page, D. C. (1992). The human Y chromosome: overlapping DNA clones spanning the euchromatic region. *Science* **258**, 60–66.
- Foresta, C., Ferlin, A., Garolla, A., Moro, E., Pistorello, M., Barboux, S., and Rossato, M. (1998). High frequency of well-defined Y-chromosome deletions in idiopathic Sertoli cell-only syndrome. *Hum Reprod* **13**, 302–307.
- Foresta, C., Ferlin, A., and Moro, E. (2000). Deletion and expression analysis of AZFa genes on the human Y chromosome revealed a major role for DBY in male infertility. *Hum Mol Genet* **9**, 1161–1169.
- Fornerod, M., Ohno, M., Yoshida, M., and Mattaj, I. W. (1997). CRM1 is an export receptor for leucine-rich nuclear export signals. *Cell* **19**, 967–970.
- Grbavec, D., Lo, R., Liu, Y., Greenfield, A., and Stifani, S. (1999). Groucho/transducin-like enhancer of split (TLE) family members interact with the yeast transcriptional corepressor SSN6 and mammalian SSN6-related proteins: implications for evolutionary conservation of transcription repression mechanisms. *Biochem J* **337**, 13–17.
- Greenfield, A., Scott, D., Pennisi, D., Ehrmann, I., Ellis, P., Cooper, L., Simpson, E., and Koopman, P. (1996). An H-Y^d epitope is encoded by a novel mouse Y chromosome gene. *Nat Genet* **14**, 474–478.
- Hadziselimovic, F. (1977). Cryptorchidism: ultrastructure of normal and cryptorchid testicular development. *Adv Anat Embryol Cell Biol* **53**, 1–72.
- Hall, N. M., Brown, G. M., Furlong, R. A., Sargent, C. A., Mitchell, M., Rocha, D., and Affara, N. A. (2003). Usp9y (ubiquitin-specific protease 9 gene on the Y) is associated with a functional promoter and encodes an intact open reading frame homologous to Usp9x that is under selective constraint. *Mamm Genome* **14**, 437–447.
- Hennig, W. (1988). Spermatogenesis in *Drosophila*. In: *Developmental Genetics of Higher Organisms*, G. M. Malacinski, ed., Macmillan Publishing, New York, pp. 239–274.
- Herbst, H., Kuhler-Obbarius, C., Lauke, H., Sauter, M., Mueller-Lantsch, N., Harms, D., and Loning, T. (1999). Human endogenous retrovirus (HERV)-K transcripts in gonadoblastomas and gonadoblastoma-derived germ cell tumours. *Virchows Arch* **434**, 11–15.

- Hilscher, B. (1979). Spermatogoniogenesis, an interacting proliferation process between stem cell spermatogonia and differentiating spermatogonia. *Föhringer Symp, Midlum/Alkersum*.
- Hilscher, B., and Engemann, A. (1992). Histological and morphometric studies on the kinetics of germ cells and immature Sertoli cells during human prespermatogenesis. *Andrologia* **7**, 7–10.
- Hochstenbach, R., and Hackstein, J. H. (2000). The comparative genetics of human spermatogenesis: clues from flies and other model organisms. *Results Probl Cell Differ* **28**, 271–298.
- Hofmann, M. C., Hess, R. A., Goldberg, E., and Millan, J. L. (1994). Immortalized germ cells undergo meiosis in vitro. *Proc Natl Acad Sci U S A* **91**, 5533–5537.
- Holdcraft, R. W., and Braun, R. E. (2004). Hormonal regulation of spermatogenesis. *Int J Androl* **27**, 335–342.
- Johnstone, O., Deuting, R., Bock, R., Linder, P., Fuller, M. T., and Lasko, P. (2005). Belle is a Drosophila DEAD-box protein required for viability and in the germ line. *Dev Biol* **277**, 92–101.
- Jones, M. H., Furlong, R. A., Burkin, H., Chalmers, I. J., Brown, G. M., Khwaja, O., and Affara, N. A. (1996). The Drosophila developmental gene fat facets has a human homologue in Xp11.4 which escapes X-inactivation and has related sequences on Yq11.2. *Hum Mol Genet* **5**, 1695–1701.
- Kamp, C., Hirschmann, P., Voss, H., Huellen, K., and Vogt, P. H. (2000). Two long homologous retroviral sequence blocks in proximal Yq11 cause AZFa microdeletions as a result of intrachromosomal recombination events. *Hum Mol Genet* **9**, 2563–2572.
- Kamp, C., Huellen, K., Fernandes, S., Sousa, M., Schlegel, P. N., Mielnik, A., Kleiman, S., Yavetz, H., Krause, W., Kupker, W., Johannisson, R., Schulze, W., Weidner, W., Barros, A., and Vogt, P. H. (2001). High deletion frequency of the complete AZFa sequence in men with Sertoli-cell-only syndrome. *Mol Hum Reprod* **7**, 987–994.
- Keleher, C. A., Redd, M. J., Schultz, J., Carlson, M., and Johnson, A. D. (1992). Ssn6-Tup1 is a general repressor of transcription in yeast. *Cell* **68**, 709–719.
- Kersemaekers, A. M., Honecker, F., Stoop, H., Cools, M., Molier, M., Wolffenbuttel, K., Bokemeyer, C., Li, Y., Lau, Y. F., Oosterhuis, J. W., and Looijengy, L. H. (2005). Identification of germ cells at risk for neoplastic transformation in gonadoblastoma: an immunohistochemical study for OCT3/4 and TSPY. *Hum Pathol* **36**, 512–521.
- Kierszenbaum, A. L., and Tres, L. L. (2001). Primordial germ cell-somatic cell partnership: a balancing cell signaling act. *Mol Reprod Dev* **60**, 277–280.
- Kim, Y-S., Lee, S-G., Park, S. H., and Song, K. (2001). Gene structure of the human DDX3 and chromosome mapping of its related sequences. *Mol Cells* **12**, 206–214.
- Kirsch, S., Keil, R., Edelmann, A., Henegariu, O., Hirschmann, P., LePaslier, D., and Vogt, P. H. (1996). Molecular analysis of the genomic structure of the human Y chromosome in the euchromatic part of its long arm (Yq11). *Cytogenet Cell Genet* **75**, 197–206.
- Kirsch, S., Weiss, B., Miner, T. L., Waterston, R. H., Clark, R. A., Eichler, E. E., Munch, C., Schempp, W., and Rappold, G. (2005). Interchromosomal segmental duplications of the pericentromeric region on the human Y chromosome. *Genome Res* **15**, 195–204.
- Koopman, P., Gubbay, J., Vivian, N., Goodfellow, P., and Lovell-Badge, R. (1991). Male development of chromosomally female mice transgenic for *Sry*. *Nature* **351**, 117–121.

- Krausz, C., Forti, G., and McElreavey, K. (2003). The Y chromosome and male fertility and infertility. *Int J Androl* **26**, 70–75.
- Krco, C., and Goldberg, E. H. (1976). H-Y (male) antigen: detection on eight-cell mouse embryos. *Science* **193**, 1134–1135.
- Lahn, B. T., and Page, D. C. (1997). Functional coherence of the human Y chromosome. *Science* **278**, 675–680.
- Lahn, B. T., and Page, D. C. (1999). Retroposition of autosomal mRNA yielded testis-specific gene family on human Y chromosome. *Nat Genet* **21**, 429–433.
- Lahn, B. T., Pearson, N. M., and Jegalian, K. (2001). The human Y chromosome, in the light of evolution. *Genetics* **2**, 207–216.
- Lamb, J. R., Tugendreich, S., and Hieter, P. (1995). Tetratricopeptide repeat interactions: to TPR or not to TPR? *Trends Biochem Sci* **20**, 257–259.
- Lee, K. H., Song, G. J., Kang, I. S., Kim, S. W., Paick, J.-S., Chung, C. H., and Rhee, K. (2003). Ubiquitin-specific protease activity of USP9Y, a male infertility gene on the Y chromosome. *Reprod Fertil Dev* **15**, 129–133.
- Leroy, P., Alzari, P., Sassooun, D., and Wolgemuth, D. (1989). The protein encoded by a murine male germ cell-specific transcript is a putative ATP-dependent RNA helicase. *Cell* **57**, 549–559.
- Longo, F. J., Mathews, L., Gururajan, R., Chen, J., and Weeks, D. L. (1996). Changes in nuclear localization of An3, a RNA helicase, during oogenesis and embryogenesis in *Xenopus laevis*. *Mol Reprod Dev* **45**, 491–502.
- Luciani, J. M., Devictor, M., and Stahl, A. (1977). Preleptotene chromosome condensation stage in human foetal and neonatal testes. *J Embryol Exp Morphol* **38**, 175–186.
- Ma, K., Sharkey, A., Kirsch, S., Vogt, P., Keil, R., Hargreave, T. B., McBeath, S., and Chandley, A. C. (1992). Towards the molecular localization of the AZF locus: mapping of microdeletions in azoospermic men within 14 subintervals of interval 6 of the human Y chromosome. *Hum Mol Genet* **1**, 29–33.
- Mamiya, N., and Worman, H. J. (1999). Hepatitis C virus core protein binds to a DEAD box RNA helicase. *J Biol Chem* **274**, 15751–15756.
- Mancini, R. E., Narbaitz, R., and Levieri, J. C. (1960). Origin and development of the germinative epithelium and Sertoli cells in the human testis: cytological, cytochemical, and quantitative study. *Anat Rec* **136**, 477–490.
- Matzuk, M. M., and Lamb, D. J. (2002). Genetic dissection of mammalian fertility pathways. *Nat Cell Biol (Suppl)* **4**, s41–s49.
- Mazeyrat, S., Saut, N., Grigoriev, V., Mahadevaiah, S. K., Ojarikre, O. A., Rattigan, A., Bishop, C., Eicher, E. M., Mitchell, M. J., and Burgoyne, P. S. (2001). A Y-encoded subunit of the translation initiation factor *Eif2* is essential for mouse spermatogenesis. *Nat Genet* **29**, 49–53.
- Mazeyrat, S., Saut, N., Sargent, C. A., Grimmond, S., Longepied, G., Ehrmann, I. E., Ellis, P. S., Greenfield, A., Affara, N. A., and Mitchell, M. J. (1998). The mouse Y chromosome interval necessary for spermatogonial proliferation is gene dense with syntenic homology to the human AZFa region. *Hum Mol Genet* **7**, 1713–1724.
- McLaren, A. (1991). Development of the mammalian gonad: the fate of the supporting cell lineage. *Bioessays* **13**, 151–156.
- McLaren, A. (1994). Germline and soma: interactions during early mouse development. *Dev Biol* **5**, 43–49.

- Mochizuki, K., Nishimiya-Fujisawa, C., and Fujisawa, T. (2001). Universal occurrence of the vasa-related genes among metazoans and their germline expression in Hydra. *Dev Genes Evol* **211**, 299–308.
- Müller, U., Aschmoneit, I., Zenzen, M. T., and Wolf, U. (1978). Binding studies of H-Y antigen in rat tissues: indications for a gonad-specific receptor. *Hum Genet* **43**, 151–157.
- Murphy, W. J., Sun, S., Cheen, Z.-Q., Pecon-Slattery, J., and O'Brien, S. J. (1999). Extensive conservation of sex chromosome organization between cat and human revealed by parallel radiation hybrid mapping. *Genome Res* **9**, 1223–1230.
- Noma, T., Kanai, Y., Kanai-Azuma, M., Ishii, M., Fujisawa, M., Kurohmaru, M., Kawakami, H., Wood, S. A., and Hayashi, Y. (2002). Stage- and sex-dependent expressions of Usp9x, an X-linked mouse ortholog of Drosophila fat facets, during gonadal development and oogenesis in mice. *Mech Dev* **119**(Suppl 1), S91–S95.
- O'Reilly, A. J., Affara, N. A., Simpson, E., Chandler, P., Goulmy, E., and Ferguson-Smith, M. A. (1992). A molecular deletion map of the Y chromosome long arm defining X and autosomal homologous regions and the localisation of the HYA locus to the proximal region of the Yq euchromatin. *Hum Mol Genet* **1**, 379–385.
- Pantaleon, M., Kanai-Azuma, M., Mattick, J. S., Kaibuchi, K., Kaye, P. L., and Wood, S. A. (2001). FAM deubiquitylating enzyme is essential for preimplantation mouse embryo development. *Mech Dev* **109**, 151–160.
- Park, S. H., Lee, S.-G., Kim, Y., and Song, K. (1998). Assignment of a human putative RNA helicase gene, DDX3, to human X chromosome bands p11.3 → p11.23. *Cytogenet Cell Genet* **81**, 178–179.
- Pelliniemi, L. J., Fröjdman, K., and Paranko, J. (1993). Embryological and prenatal development and function of Sertoli cells. In: *The Sertoli Cell*, L. D. Russell & M. D. Griswold, eds., Cache River Press, Clearwater, FL, pp. 365–390.
- Politzer, G. (1933). Die Keimbahn des Menschen. *Z Anat Entwicklungsgesch* **100**, 331–361.
- Quilter, C. R., Blott, S. C., Mileham, A. J., Affara, N. A., Sargent, C. A., and Griffin, D. K. (2002). A mapping and evolutionary study of porcine sex chromosome genes. *Mamm Genome* **13**, 588–594.
- Qureshi, S. J., Ross, A. R., Ma, K., Cooke, H. J., McIntyre, M. A., Chandley, A. C., and Hargreave, T. B. (1996). Polymerase chain reaction screening for Y chromosome microdeletions: a first step towards the diagnosis of genetically-determined spermatogenic failure in men. *Mol Hum Reprod* **2**, 775–779.
- Rocak, S., and Linder, P. (2004). DEAD-box proteins: the driving forces behind RNA metabolism. *Nat Rev Mol Cell Biol* **5**, 232–241.
- Ross, A. J., and Capel, B. (2005). Signaling at the crossroads of gonad development. *Trends Endocrinol Metab* **16**, 19–25.
- Rowley, M. J., Berlin, J. D., and Heller, C. G. (1971). The ultrastructure of four types of human spermatogonia. *Z Zellforsch Mikrosk Anat* **112**, 139–157.
- Salo, P., Kaariainen, H., Petrovic, V., Peltomaki, P., Page, D. C., and de la Chapelle, A. (1995). Molecular mapping of the putative gonadoblastoma locus on the Y chromosome. *Genes Chromosomes Cancer* **14**, 210–214.
- Sandberg, A. A., ed. (1985). *Clinical Aspects of Y Chromosome Abnormalities. Progress and Topics in Cytogenetics*, Vol. 6, part B, Alan R. Liss Inc., New York.
- Schlegel, P. N. (2002). The Y chromosome. *Reprod Biomed Online* **5**, 22–25.

- Schmid, S. R., and Linder, P. (1992). DEAD protein family of putative RNA helicases. *Mol Microbiol* **6**, 283–292.
- Schnieders, F., Dork, T., Arnemann, J., Vogel, T., Werner, M., and Schmidtke, J. (1996). Testis-specific protein, Y-encoded (TSPY) expression in testicular tissue. *Hum Mol Genet* **5**, 1801–1807.
- Schultz, J., Marshall-Carlson, L., and Carlson, M. (1990). The N-terminal TPR region is the functional domain of SSN6, a nuclear phosphoprotein of *Saccharomyces cerevisiae*. *Mol Cell Biol* **10**, 4744–4756.
- Schulze, W. (1978). Zum problem der morphologischen charakterisierung von spermatogonientypen beim erwachsenen. *Verh Anat Ges* **72**, 539–540.
- Sekiguchi, T., Iida, H., Fukumura, J., and Nishimoto, T. (2004). Human DDX3Y, the Y-encoded isoform of RNA helicase DDX3, rescues a hamster temperature-sensitive ET24 mutant cell line with a DDX3X mutation. *Exp Cell Res* **300**, 213–222.
- Session, D. R., Lee, G. S., and Wolgemuth, D. J. (2001). Characterization of D1Pas1, a mouse autosomal homologue of the human AZFa region DBY, as a nuclear protein in spermatogenic cells. *Fertil Steril* **76**, 804–811.
- Skaletsky, H., Kuroda-Kawaguchi, T., Minx, P. J., Cordum, H. S., Hillier, L., Brown, L. G., Repping, S., Pyntikova, T., Ali, J., Bieri, T., *et al.* (2003). The male-specific region of the human Y chromosome is a mosaic of discrete sequence classes. *Nature* **423**, 825–837.
- Sowden, J., Putt, W., Morrison, K., Beddington, R., and Edwards, Y. (1995). The embryonic RNA helicase gene (ERH): a new member of the DEAD box family of RNA helicases. *Biochem J* **308**, 839–846.
- Sun, C., Skaletsky, H., Birren, B., Devon, K., Tang, Z., Silber, S., Oates, R., and Page, D. C. (1999). An azoospermic man with a de novo point mutation in the Y-chromosomal gene USP9Y. *Nat Genet* **23**, 429–432.
- Sun, C., Skaletsky, H., Rozen, S., Gromoll, J., Nieschlag, E., Oates, R., and Page, D. C. (2000). Deletion of azoospermia factor a (AZFa) region of human Y chromosome caused by recombination between HERV15 proviruses. *Hum Mol Genet* **9**, 2291–2296.
- Sutcliffe, M. J., and Burgoyne, P. S. (1989). Analysis of the testes of H-Y negative XO Sxr^b mice suggests that the spermatogenesis gene (Spy) acts during the differentiation of the A spermatogonia. *Development* **107**, 373–380.
- Terada, T., and Hatakeyama, S. (1991). Morphological evidence for two types of idiopathic ‘Sertoli-cell-only’ syndrome. *Int J Androl* **14**, 117–126.
- The Y Chromosome Consortium. (2002). A nomenclature system for the tree of human Y-chromosomal binary haplogroups. *Genome Res* **12**, 339–348.
- Tiepolo, L., and Zuffardi, O. (1976). Localization of factors controlling spermatogenesis in the nonfluorescent portion of the human Y chromosome long arm. *Hum Genet* **34**, 119–124.
- Tonks, N. K., and Neel, B. G. (1996). From form to function: signaling by protein tyrosine phosphatases. *Cell* **87**, 365–368.
- Tran, D., Picard, J. Y., Campargue, J., and Josso, N. (1987). Immunocytochemical detection of anti-Müllerian hormone in Sertoli cells of various mammalian species including human. *J Histochem Cytochem* **35**, 733–743.
- Tsuchiya, K., Reijo, R., Page, D. C., and Disteche, C. M. (1995). Gonadoblastoma: molecular definition of the susceptibility region on the Y chromosome. *Am J Hum Genet* **57**, 1400–1407.

- Vergnaud, G., Page, D. C., Simmler, M.-C., Brown, L., Rouyer, F., Noel, B., Botstein, D., de la Chapelle, A., and Weissenbach, J. (1986). A deletion map of the human Y chromosome based on DNA hybridization. *Am J Hum Genet* **38**, 109–124.
- Verp, M. S., and Simpson, J. L. (1987). Abnormal sexual differentiation and neoplasia. *Cancer Genet Cytogenet* **25**, 191–218.
- Vogt, M. H. J., Goulmy, E., Kloosterboer, F. M., Blokland, E., de Paus, R. A., Willemze, R., and Falkenburg, J. H. F. (2000a). UTY gene codes for an HLA-B60-restricted human male-specific minor histocompatibility antigen involved in stem cell graft rejection: characterization of the critical polymorphic amino acid residues for T-cell recognition. *Blood* **96**, 3126–3132.
- Vogt, M. H. J., de Paus, R. A., Voogt, P. J., Willemze, R., and Falkenburg, J. H. F. (2000b). DFFRY codes for a new human male-specific minor transplantation antigen involved in bone marrow graft rejection. *Blood* **95**, 1100–1105.
- Vogt, M. H. J., van den Muijsenberg, J. W., Goulmy, E., Spierings, E., Kluck, P., Kester, M. G., van Soest, R. A., Drijfhout, J. W., Willemze, R., and Falkenburg, J. H. F. (2002). The DBY gene codes for an HLA-DQ5-restricted human male-specific minor histocompatibility antigen involved in graft-versus-host disease. *Blood* **99**, 3027–3032.
- Vogt, P., Keil, R., and Kirsch, S. (1993). The AZF-function of the human Y chromosome during spermatogenesis. In: *Chromosomes Today*, Vol. 11, A. T. Sumner & A. C. Chandley, eds., Chapman & Hall, London, pp. 227–239.
- Vogt, P. H. (1998). Human chromosome deletions in Yq11, AZF candidate genes and male infertility: history and update. *Mol Hum Reprod* **4**, 739–744.
- Vogt, P. H. (2005a). Azoospermia factor (AZF) in Yq11: towards a molecular understanding of its function for human male fertility and spermatogenesis. *Reprod Biomed Online* **10**, 81–93.
- Vogt, P. H. (2005b). AZF deletions and Y chromosomal haplogroups: history and update based on sequence. *Hum Reprod Update* **11**, 319–336.
- Vogt, P. H., Edelmann, A., Kirsch, S., Henegariu, O., Hirschmann, P., Kiesewetter, F., Köhn, F. M., Schill, W. B., Farah, S., Ramos, C., et al. (1996). Human Y chromosome azoospermia factors (AZF) mapped to different subregions in Yq11. *Hum Mol Genet* **5**, 933–943.
- Vollrath, D., Foote, S., Hilton, A., Brown, L. G., Beer-Romero, P., Bogan, J. S., and Page, D. C. (1992). The human Y chromosome: a 43-interval map based on naturally occurring deletions. *Science* **258**, 52–59.
- Wang, P. J. (2004). X chromosomes, retrogenes and their role in male reproduction. *Trends Endocrinol Metab* **15**, 79–83.
- Wang, W., Meadows, L. R., den Haan, J. M., Sherman, N. E., Chen, Y., Blokland, E., Shabanowitz, J., Agulnik, A. I., Hendrickson, R. C., Bishop, C. E., et al. (1995). Human H-Y: a male-specific histocompatibility antigen derived from the SMCY protein. *Science* **269**, 1515–1516.
- Warren, E. H., Gavin, M. A., Simpson, E., Chandler, P., Page, D. C., Disteché, C., Stankey, K. A., Greenberg, P. D., and Riddell, S. R. (2000). The human UTY gene encodes a novel HLA-B8-restricted H-Y antigen. *J Immunol* **164**, 2807–2814.
- Wartenberg, H. (1989). Differentiation and development of the testes. In: *The Testis*, 2nd ed., H. Burger & D. de Kretser, eds., Raven Press, New York, pp. 67–118.
- Wartenberg, H., Holstein, A. F., and Vossmeier, J. (1971). Zur cytologie der pränatalen gonadenentwicklung beim menschen. II. Elektronenmikroskopische untersuchungen

- ueber die cytogenese von gonocyten und fetalen spermatogonien im hoden. *Z Anat Entwicklungsgesch* **134**, 165–185.
- Waters, P. D., Duffy, B., Frost, C. J., Delbridge, M. L., and Graves, J. A. M. (2001). The human Y chromosome derives largely from a single autosomal region added to the sex chromosomes 80-130 million years ago. *Cytogenet Cell Genet* **92**, 74–79.
- Wilkie, A. O. (1994). The molecular basis of genetic dominance. *J Med Genet* **31**, 89–98.
- Wimmer, R., Kirsch, S., Weber, A., Rappold, G. A., and Schempp, W. (2002). The azoospermia region AZFa: an evolutionary view. *Cytogenet Genome Res* **99**, 146–150.
- Witschi, E. (1948). Migration of the germ cells of human embryos from the yolk sac to the primitive gonadal folds. *Contrib Embryol* **209**, 67–80.
- Wolkowicz, M. J., Coonrod, S. A., Reddi, P. P., Millan, J. L., Hofmann, M. C., and Herr, J. C. (1996). Refinement of the differentiated phenotype of the spermatogenic cell line GC-2spd(ts). *Biol Reprod* **55**, 923–932.
- Zenzes, M. T., Mueller, U., Aschmoneit, I., and Wolf, U. (1978). Studies on H-Y antigen in different cell fractions of the testis during pubescence. *Hum Genet* **45**, 297.
- Zhu, Y., Carroll, M., Papa, F. R., Hochstrasser, M., and D'Andrea, A. D. (1996). *DUB-1*, a deubiquitinating enzyme with growth-suppressing activity. *Proc Natl Acad Sci U S A* **93**, 3275–3279.

This page intentionally left blank

CHAPTER 6

RBMY AND DAZ IN SPERMATOGENESIS

Pauline Yen

*Institute of Biomedical Sciences,
Academia Sinica, Taiwan*

RBMY and *DAZ* are the first two azoospermia factors isolated from the *AZF* regions of the human Y chromosome that are frequently deleted in subfertile men. Both factors encode RNA-binding proteins that are expressed exclusively in male germ cells. There are six functional *RBMY* genes within the *AZFb* region. Together with the *RBMX* gene on the X chromosome and the *HNRNP G-T* gene on chromosome 11, they make up the *HNRNP G* family. The hnRNP G proteins have a nuclear localization and function in the regulation of pre-mRNA splicing. The four *DAZ* genes within the *AZFc* region belong to the *DAZ* gene family, which includes two additional autosomal genes, *BOULE* and *DAZL*. The *DAZ* proteins are present in both the nuclei and the cytoplasm of germ cells, and appear to play a role in the regulation of mRNA translation. The expression of *DAZ* and *DAZL* in fetal gonocytes, in addition to adult testes, indicates that they are involved in primordial germ cell development as well as spermatogenesis. The downstream targets of *RBMY* and *DAZ* remain elusive. Neither *RBMY* nor *DAZ* appears to be essential for spermatogenesis, and their functions may partially overlap those of their X-linked or autosomal homologs.

Keywords: Y chromosome microdeletion; *AZF*; male infertility.

Introduction

In 1976, Tiepolo and Zuffardi reported the identification of six subfertile men with cytogenetically detectable Y chromosome deletions, and proposed the presence of factors controlling spermatogenesis — dubbed the azoospermia factors (*AZFs*) — on the human Y chromosome long arm (Tiepolo and Zuffardi, 1976). This initial observation established a link between male infertility and the Y chromosome, and opened up a new field

Corresponding author: Pauline Yen; e-mail: pyen@ibms.sinica.edu.tw

of active research. Much of the work carried out in the following decade focused on the cloning of new Y chromosome markers and on the construction of deletion maps of the Y chromosome (reviewed in Yen, 1999). With the availability of new molecular probes, Y chromosome microdeletions were detected and mapped to three different regions on the long arm, later designated as *AZF_a*, *AZF_b*, and *AZF_c* from proximal to distal (Vogt *et al.*, 1996). Using the positional cloning approach, the first *AZF* candidate gene family, *RBMY* (RNA-binding motif, Y; originally known as *YRRM*), was isolated from the *AZF_b* region in 1993; this was followed by the cloning of the *DAZ* (deleted in azoospermia) gene family from the *AZF_c* region 2 years later (Ma *et al.*, 1993; Reijo *et al.*, 1995).

The structures and gene contents of the *AZF* regions are now well defined. *AZF_a* is the smallest, covering 800 kb and 3 genes (Kamp *et al.*, 2000; Sun *et al.*, 2000). *AZF_b* spans 6.2 Mb and contains 32 genes, and *AZF_c* spans 3.5 Mb and contains 21 genes (Fig. 1; Kuroda-Kawaguchi *et al.*, 2001; Repping *et al.*, 2002). Most of the *AZF* deletions are caused by homologous recombination between long direct repeats that make up a large portion of the Y chromosome long arm (Skaletsky *et al.*, 2003). A majority of the genes/gene families within the deleted regions are expressed exclusively in the testis. Of these genes, *RBMY* and *DAZ* are the best characterized. *RBMY* functions as a pre-mRNA splice regulator in the nucleus, and *DAZ* appears to regulate mRNA translation in the cytoplasm (reviewed in Elliott, 2004; Yen, 2004). These proteins do not appear to be essential for spermatogenesis, and the infertile phenotypes associated with the *AZF_b* and *AZF_c* deletions are likely the cumulative effect of deficiency in several, rather than single, genes/gene families (Saut *et al.*, 2000; Szot *et al.*, 2003).

The *RBMY* Gene Family

Gene and protein structure

RBMY was originally isolated in two cDNA clones, MK5 and MK29, from a human testis cDNA library (Ma *et al.*, 1993). MK5 encodes a protein of 496 amino acid residues. It has an RNA-recognition motif (RRM) in the N-terminal portion and four copies of a 37-amino-acid SRGY box, which is rich in serine, arginine, glycine, and tyrosine, in the C-terminal portion (Fig. 2). MK29 had a 5 bp deletion in the 3' portion of the coding region that

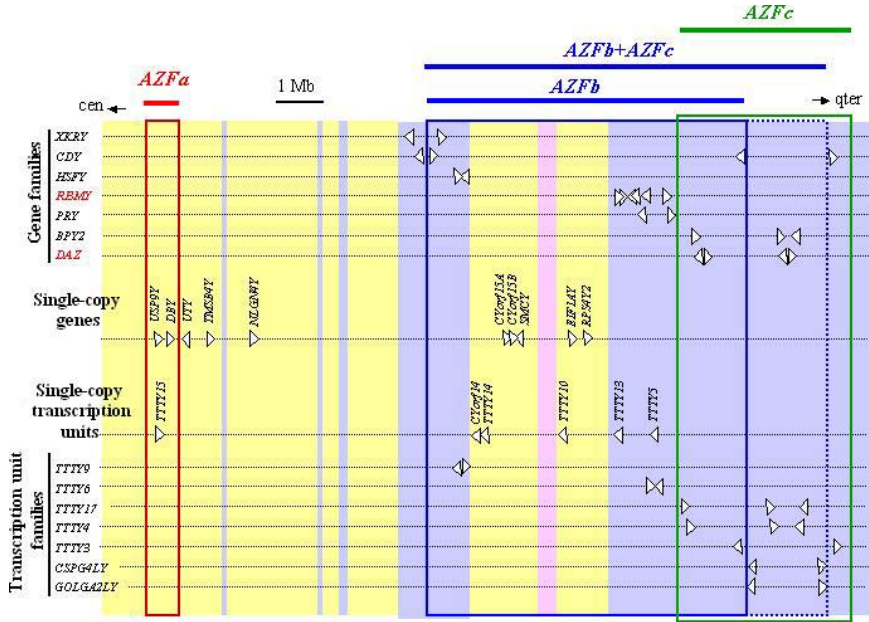
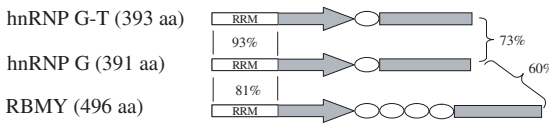

Fig. 1. The AZF regions of the human Y chromosome long arm (modified from Skaletsky *et al.*, 2003). The yellow areas contain X-degenerated sequences, and the blue areas contain ampliconic sequences. Transcription units are indicated as open triangles, and the various AZF regions are boxed.

was later shown to represent a processing irregularity (Chai *et al.*, 1997). There are about 30 copies of *RBMY* homologous sequences scattered on both arms of the Y chromosome (Chandley and Cooke, 1994). Using an *RBMY*-specific antibody and a panel of males with known Y chromosome deletions and testicular pathologies, Elliott *et al.* (1997) mapped a critical region for *RBMY* expression to *AZFb*. With the completion of Y chromosome sequencing, it is now clear that there are six functional *RBMY* genes clustered within a 1-Mb interval on the distal portion of *AZFb* (Fig. 1; Skaletsky *et al.*, 2003). The six genes differ in a few bases and produce four different polypeptides, due to some silent base substitutions (Chai *et al.*, 1997). In addition, each gene can produce two protein isoforms with three or four SRGY boxes through alternative splicing.

RBMY orthologs were present on the Y chromosome of several mammals tested, including gorilla, rabbit, cow, and mouse (Ma *et al.*, 1993). Mice

The hnRNP G family



The DAZ family

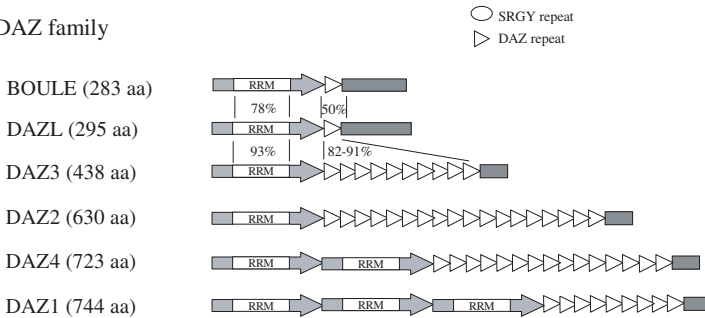

Fig. 2. The hnRNP G and DAZ protein families. The RNA-recognition motifs (RRMs) are boxed, and the SRGY and DAZ repeats are depicted as open circles and open triangles, respectively. Amino acid similarities between the various domains are indicated. The copy numbers of the DAZ repeats in the DAZ proteins are taken from the *DAZ* genes in the individual RPCI-11 (Kuroda-Kawaguchi *et al.*, 2001).

have more than 50 copies of *Rbmy* as part of the *Sx1* tandem repeat on the Y chromosome short arm (Elliott *et al.*, 1996; Mahadevaiah *et al.*, 1998). These genes encode RNA-binding proteins with a single SRGY repeat. Deletion of most of the *Rbmy* genes results in diminished expression of RBMY without affecting the fertility of the mice (Mahadevaiah *et al.*, 1998), although there appears to be a significant increase in abnormal sperm. The role of *Rbmy* in sperm development thus remains unclear (Szot *et al.*, 2003).

Expression and biological functions

RBMY is expressed specifically in male germ cells. Immunostaining of adult human testicular sections showed RBMY in the nuclei of all transcriptionally active germ cells, including spermatogonia, spermatocytes, and round spermatids (Elliott *et al.*, 1998; Osterlund *et al.*, 2001). In mice, RBMY was found abundantly in the nuclei of spermatogonia; and its expression level was diminished in late zygotene spermatocytes and

completely abolished in pachytene spermatocytes, due to meiotic sex chromosome inactivation and the formation of the XY body (Mahadevaiah *et al.*, 1998; Turner *et al.*, 2002). Although the transcription of *Rbmy* reinitiated in round spermatids, no RBMY protein was detected in the cells (Szot *et al.*, 2003). The different expression patterns observed in humans and in mice could be real; however, they could also be caused by compromised specificity of the antibodies being used (Szot *et al.*, 2003).

RBMV has two paralogs, *RBMX* and *HNRNP G-T*, in the human genome. The X-linked *RBMX* gene encodes the ubiquitously expressed heterogeneous nuclear ribonucleoprotein hnRNP G, which shares 60% amino acid sequence identity with RBMY (Soulard *et al.*, 1993; Delbridge *et al.*, 1999; Mazeyrat *et al.*, 1999). The *HNRNP G-T* gene on chromosome 11 encodes a germ cell-specific nuclear protein that is 73% and 53% identical to hnRNP G and RBMY, respectively (Elliott *et al.*, 2000). The RRM regions of these proteins show the highest conservation. Both hnRNP G and hnRNP G-T have only one SRGY box, similar to the mouse RBMY. The *HNRNP G-T* gene contains no intron, and is thought to originate from the retrotransposition of an ancient *RBMX* gene. It is expressed most abundantly in pachytene spermatocytes in both humans and mice, and may partially replace RBMY and hnRNP G during meiotic sex chromosome inactivation.

Several pieces of evidence support a role of the hnRNP G family — including RBMY, hnRNP G, and hnRNP G-T — in the regulation of RNA splicing (reviewed in Elliott, 2004). The hnRNP G proteins contain the characteristic SR/RS dipeptides, which are present in the SR protein family of pre-mRNA splicing factors, in the SRGY boxes. They have a nuclear distribution similar to components of the pre-mRNA splicing machinery, and interact with several members of the SR family (Elliott *et al.*, 2000). They also interact through the SRGY repeats with Tra2 β , a ubiquitously expressed pre-mRNA splicing activator that is highly expressed in the testis (Venables *et al.*, 2000; Hofmann and Wirth, 2002). In *ex vivo* splicing assays, both RBMY and hnRNP G acted as transacting splicing factors through direct interaction with Tra2 β to promote the inclusion of exon 7 of survival motor neuron 2 (*SMN2*) in the mRNA transcripts (Hofmann and Wirth, 2002). Both hnRNP G and Tra2 β could act either as an activator or as a repressor, and they appeared to have opposite effects on the incorporation of several exons (Nasim *et al.*, 2003). In summary, accumulating data indicate

that RBMY is a germ cell-specific splice regulator for the more ubiquitously expressed pre-mRNA splicing activators (Elliott, 2004).

A few recent reports suggest additional functions for the hnRNP G protein family. The interaction of RBMY with SAM68 and T-STAR, two proteins that have been implicated in signaling and cell cycle control, suggests that RBMY may be involved in these processes (Venables *et al.*, 1999; Elliott, 2004). RBMY also appears to possess oncogenic potential: although normally expressed only in the testis, it is detected in 36% of hepatocellular carcinomas and 67% of hepatoblastomas (Tsuei *et al.*, 2004). It can also transform mouse fibroblast NIH3T3 cells, and confers on them the ability to induce tumor formation in nude mice. Finally, the zebrafish *rbmx* ortholog is reported to be essential for brain development (Tsend-Ayush *et al.*, 2005). Knocking down *rbmx* expression in early embryos results in animals with underdeveloped head and eyes, defective somite patterning, and absence of jaws.

The DAZ Gene Family

Gene and protein structure

Within *AZFc*, most men have four *DAZ* genes, arranged in two head-to-head arrays 1.6 Mb apart (Fig. 1; Saxena *et al.*, 2000; Kuroda-Kawaguchi *et al.*, 2001). The *DAZ* genes encode RNA-binding proteins with different copies of RRM in the N-terminal portions, followed by a *DAZ* repeat region containing 8 to 24 copies of a 24-amino-acid *DAZ* repeat (Fig. 2; Reijo *et al.*, 1995; Saxena *et al.*, 2000). Thus, *DAZ2* and *DAZ3* each contain a single RRM, and *DAZ4* and *DAZ1* have two and three RRMs, respectively. These *DAZ* proteins are likely to bind RNA with different affinities, and may not be functionally equivalent (Kanaar *et al.*, 1995). The *DAZ* repeat regions are highly polymorphic in the general population, and appear to be involved in protein-protein interaction (Yen *et al.*, 1997; Tsui *et al.*, 2000a; Moore *et al.*, 2004). The sizes of the four *DAZ* proteins therefore can vary from 43 kD (1 RRM and 8 *DAZ* repeats) to over 120 kD (3 RRMs and 24 *DAZ* repeats). Whether all four *DAZ* protein products are present in human testes is unclear. Results of Western blot analyses published so far showed the presence of a single band at around 45 kD (Slee *et al.*, 1999; Reijo *et al.*, 2000).

Deletions and duplications

The *AZFc* region consists entirely of very long repeats and is prone to rearrangement (Fig. 3A; Kuroda-Kawaguchi *et al.*, 2001). The *AZFc* deletion, present in about 1 in 4000 men, is caused by homologous recombination between the b2 and b4 repeats, and removes all four *DAZ* genes (Fig. 3B; Page, 2004). About 6% of the world's population have only two *DAZ* genes, due to deletions that remove portions of *AZFc* (Jobling *et al.*, 1996; Repping *et al.*, 2003; Repping *et al.*, 2004; Fernandes *et al.*, 2002; Fernandes *et al.*, 2004). Partial *AZFc* deletion can occur through homologous recombination between the gr repeats, or between the b1 and b3 repeats, on Y chromosomes with the reference structure of the *AZFc* region (Figs. 3C and 3D). The gr/gr

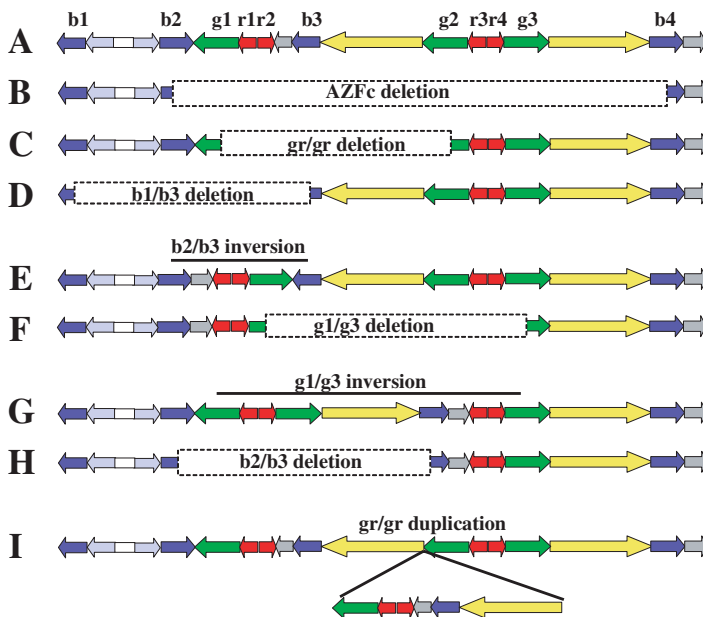

Fig. 3. Rearrangements at the *AZFc* region of the human Y chromosome. The reference structure of the *AZFc* region is shown in A, with the various repeats depicted in different colors according to Kuroda-Kawaguchi *et al.* (2001). The *DAZ* genes are embedded in the r repeats. Deletions and inversions caused by homologous recombination between different pairs of repeats are indicated. Additional rearrangements with four *DAZ* genes, such as b2/b4 duplication on gr/gr-deleted chromosome (Repping *et al.*, 2003), or blue-gray duplication on b2/b3-deleted chromosome (Repping *et al.*, 2004), are not shown.

deletion removes 1.6 Mb of DNA sequences and nine genes; whether it is a significant risk factor for spermatogenic failure is unclear, since not all studies found the deletion to be associated with impaired fertility (de Vries *et al.*, 2002; Repping *et al.*, 2003; Machev *et al.*, 2004; Hucklenbroich *et al.*, 2005; Lynch *et al.*, 2005; Ferlin *et al.*, 2005).

Partial *AZFc* deletion can also occur on Y chromosomes carrying inversions of the reference structure, due to recombination between the inverted b2 and b3 repeats or between the g1 and g3 repeats (Figs. 3E and 3G). Recombination between the now direct g1 and g3 repeats or between the b2 and b3 repeats on these inverted Y chromosomes generates the b2/b3 deletion, which removes 1.8 Mb of DNA sequences and 12 genes (Figs. 3F and 3H; Fernandes *et al.*, 2004; Repping *et al.*, 2004) and has no effect on a man's fertility. In addition to *AZFc* partial deletion, about 1.5% of the male population worldwide have six *DAZ* genes due to partial *AZFc* duplication (Jobling *et al.*, 1996; Lin *et al.*, 2005). Molecular characterization of some of these cases indicates that they are the reciprocal products of the gr/gr deletion during nonallelic homologous recombination between sister chromatids (Fig. 3I).

The DAZ gene family and gametogenesis

The *DAZ* genes are apparently not essential for spermatogenesis. Some patients with the *AZFc* deletion can still produce mature sperm, although at a significantly reduced number (Vogt *et al.*, 1996; Krausz *et al.*, 2003). In addition, several cases of inherited *AZFc* deletion have been reported, including one case of a father who passed the deletion to four infertile sons (Chang *et al.*, 1999; Saut *et al.*, 2000; Calogera *et al.*, 2002; Kuhnert *et al.*, 2004). Nonetheless, *DAZ* has two autosomal homologs, *DAZL* (*DAZ*-like, also known as *DAZH*) and *BOULE*, which have been shown to cause sterility when defective in lower animals (reviewed in Yen, 2004; Reynolds and Cooke, 2005).

The *DAZ* gene family, including *DAZ*, *DAZL*, and *BOULE*, is thought to originate from an ancestral *BOULE* gene through two rounds of duplication (Fig. 4; Xu *et al.*, 2001; Haag, 2001). Nowadays, nematodes and insects have only *BOULE*. Duplication and translocation of *BOULE* in an ancestor of the vertebrates generated the *DAZL* gene, which further duplicated and translocated in the primate lineage to produce the Y-linked *DAZ* in great

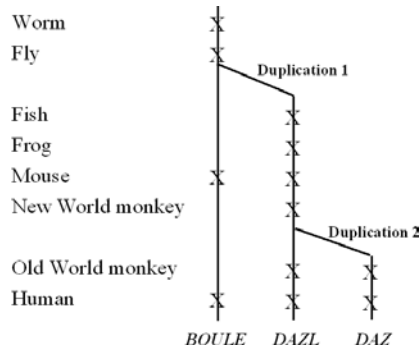

Fig. 4. A model of the evolution of the DAZ gene family. *BOULE* is the ancestral member of the family. Duplication and translocation at the branching of the vertebrates produced the *DAZL* gene. Further duplication and translocation in the primate lineage gave rise to the *DAZ* genes on the Y chromosome. The X's indicate that the genes have been identified.

apes and Old World monkeys (Saxena *et al.*, 1996; Seboun *et al.*, 1997; Gromoll *et al.*, 1999). Thus, *DAZ* is more closely related to *DAZL* than to *BOULE* (Fig. 2). Both *DAZL* and *BOULE* are single-copy genes, and their protein products contain a single RRM and one DAZ repeat that show a high degree of conservation with *DAZ*. Outside the two conserved regions, the three proteins share little similarity, yet their functions seem to be conserved. A human *DAZ* transgene was able to partially rescue the mouse *Dazl* null phenotype, and the human *BOULE* gene and the *Xenopus Xdazl* gene were able to rescue the spermatogenic defect of *Drosophila boule* mutants (Houston *et al.*, 1998; Slee *et al.*, 1999; Xu *et al.*, 2003).

BOULE is found exclusively in the testes of all animals studied except *C. elegans*, in which it is expressed only in the ovary (Table 1; Eberhart *et al.*, 1996; Karashima *et al.*, 2000; Xu *et al.*, 2001). Compared to *DAZ* and *DAZL*, *BOULE* is expressed much later during germ cell development. *Drosophila Boule* is first detected in meiotic cells at the beginning of the spermatocyte growth phase, and it becomes highly concentrated in the nucleus as the primary spermatocytes mature (Cheng *et al.*, 1998). It translocates to the cytoplasm prior to meiosis, and remains in the cytoplasm of postmeiotic spermatids. Consistent with its expression pattern, *Drosophila boule* mutants have spermatogenesis arrested at the meiotic G₂/M transition (Eberhart *et al.*, 1996). The situation in *C. elegans* is different. The only *DAZ* paralog in the nematode, *dazl*, is expressed mainly in the female germline in

Table 1. Expression and null phenotypes of the DAZ gene family.

Genes/Organisms	Expression			Phenotypes	References
	Testis	Ovary	PGC*		
<i>BOULE</i>					
<i>Drosophila</i>	+	-	-	Meiotic arrest at G ₂ /M transition	Eberhart <i>et al.</i> (1996)
<i>C. elegans</i>	-	+	-	Meiotic arrest at G ₂ /M transition	Karashima <i>et al.</i> (2000)
Mouse	+	-	-	Unknown	Xu <i>et al.</i> (2001)
Human	+	-	-	Unknown	Xu <i>et al.</i> (2001)
<i>DAZL</i>					
Zebrafish	+	+	+	Depletion of PGC	Hashimoto <i>et al.</i> (2004)
<i>Xenopus</i>	+	+	+	Depletion of PGC	Houston and King (2000)
Axolotls	+	+	+	Unknown	Johnson <i>et al.</i> (2001)
Mouse	+	+	+	Fetal germ cell loss Blockage at early meiosis	Ruggiu <i>et al.</i> (1997)
Human	+	+	+	Unknown	Reijo <i>et al.</i> (2000)
<i>DAZ</i>					
Human	+	-	+	Few or no sperm	Reijo <i>et al.</i> (2000)

*PGC: primordial germ cell.

hermaphrodites, with the highest level of expression found at the pachytene stage (Karashima *et al.*, 2000); deletion of *dazl* causes sterility, due to a block in oogenesis at this stage. In both humans and mice, BOULE first appears in the cytoplasm of spermatocytes, and persists through meiosis to the early spermatids before it disappears (Xu *et al.*, 2001). Although mice or humans deficient in BOULE have not been generated or identified, they are predicted to be sterile due to meiotic arrest.

Both DAZL and DAZ are expressed much earlier than BOULE, and appear to play an additional role in primordial germ cell development. *Dazl* transcripts are present in the oocytes and early embryos of several low vertebrates, including *Xenopus*, zebrafish, and axolotls (Houston *et al.*, 1998; Maegawa *et al.*, 1999; Johnson *et al.*, 2001). In *Xenopus*, the *Xdazl* RNA is localized to the germ plasm, but the *Xdazl* protein is not localized to any specific region in early embryos (Mita and Yamashita, 2000). *Xdazl*

disappears after gastrulation and reappears in the primordial germ cells at the genital ridge. It is present in male and female germ cells at all stages of development, except the mature spermatozoa stage. In both *Xenopus* and zebrafish, depletion of maternal *dazl* RNA in early embryos results in significant depletion of primordial germ cells in tadpoles and in zebrafish larva (Houston and King, 2000; Hashimoto *et al.*, 2004).

Human and mouse DAZL, as well as human DAZ, are found in both the nuclei and cytoplasm of fetal gonocytes and in the nuclei of spermatogonia (Reijo *et al.*, 2000). The proteins translocate to the cytoplasm during male meiosis, and are abundantly present in the cytoplasm of pachytene spermatocytes (Reijo *et al.*, 2000; Ruggiu *et al.*, 1997). DAZL is also present in the cytoplasm of oocytes (Nishi *et al.*, 1999; Dorfman *et al.*, 1999). Because mouse *Dazl* is expressed in embryonic gonads before germ cell sex differentiation, and because its expression persists in the germ cells throughout much of gametogenesis, it has been widely used as a marker for germ cell lineage (Seligman and Page, 1998; Johnson *et al.*, 2005; Chen *et al.*, 2005).

Mice with *Dazl* null mutation are sterile in both sexes (Ruggiu *et al.*, 1997). In females, germ cell loss occurs after 15.5 days postcoitum when the cells progress through meiotic prophase, and the ovaries of *Dazl*^{-/-} pups at 4 days of age contain no follicular structures or normal oocytes (Saunders *et al.*, 2003). Adult *Dazl*^{-/-} males have testes that are about one third of the normal size and that contain few tubules per cross-section, with no germ cells beyond the leptotene stage of meiotic prophase (Ruggiu *et al.*, 1997; Saunders *et al.*, 2003). Thus, in the absence of DAZL, germ cells can complete mitosis and proceed to differentiation, but cannot progress through meiotic prophase. So far, no detrimental mutations within the human *DAZL* gene have been identified, although such mutations are likely to cause infertility, regardless of the sex of the individual.

Biological functions

Several pieces of evidence suggest that the DAZ proteins function in the regulation of mRNA translation (reviewed in Yen, 2004; Reynolds and Cooke, 2005). The first and strongest piece of evidence comes from a study on the *Drosophila twine* gene, which encodes a meiosis-specific Cdc25 phosphatase (Maines and Wasserman, 1999). In the *boule* mutants, the level of Cdc25 protein (but not that of *Cdc25* mRNA) was significantly reduced,

indicating that Boule is involved in the posttranscriptional regulation of *Cdc25* expression. However, heterologous expression of *Cdc25* in spermatocytes from a transgene could only partially rescue the spermatogenic defect of *boule* mutants, suggesting that *Cdc25* is not the only downstream target of Boule. It is unclear, though, whether Boule acts directly on *Cdc25* mRNA or through intermediates. Additional supports for a role of the DAZ proteins in protein synthesis are provided by the comigration of mouse DAZL with polyribosomes on sucrose gradients and the binding of DAZL to poly A⁺ mRNA *in vivo* (Tsui *et al.*, 2000b). In addition, zebrafish DAZL could moderately enhance the expression of a reporter gene with its binding sequence GUUC in the 3' UTR both *in vitro* and in cultured CV-1 cells (Maegawa *et al.*, 2002). In a recent study using a tethered function assay that requires no prior knowledge of the *in vivo* targets, the various DAZ proteins were shown to stimulate by severalfold the initiation of translation of a reporter gene in *Xenopus* oocytes, likely through direct recruitment of poly(A)-binding proteins to the mRNA (Collier *et al.*, 2005).

Taken together, the evidence is compelling that the DAZ proteins regulate the translation of certain transcripts during gametogenesis; this role takes place in the cytoplasm. DAZ and DAZL also spend a significant amount of time in the nuclei, both in fetal gonocytes and in spermatogonia. Their nuclear function(s) is so far unclear, although they could be involved in the transport of their mRNA targets from the nucleus to the cytoplasm.

The natural RNA substrates of the DAZ proteins remain undefined, despite several attempts to identify them (Venables *et al.*, 2001; Jiao *et al.*, 2002; Fox *et al.*, 2005). Different approaches have generated different RNA consensus sequences for DAZL/DAZ binding and nonoverlapping sets of putative target genes. The SELEX (systematic evolution of ligands by exponential enrichment) and yeast three-hybrid systems yielded an RNA consensus sequence of (GUN)_n that is present in a host of genes, including the 5' UTR of the mouse *Cdc25C* gene (Venables *et al.*, 2001). Mammals have three *Cdc25* genes that are differentially expressed in the testis (Wu and Wolgemuth, 1995; Mizoguchi and Kim, 1997): *Cdc25A* is expressed in both mitotic and meiotic germ cells, *Cdc25B* is expressed only in the somatic cells, and *Cdc25C* is expressed in late spermatocytes and round spermatids. The interaction between mouse DAZL (mDAZL) and the

5' UTR of *Cdc25C* mRNA was further confirmed by an *in vitro* gel retardation assay.

However, the *Cdc25C* mRNA failed to appear in the DAZL-associated RNP particles that were isolated from mouse testes by immunoprecipitation with an anti-DAZL antibody (Jiao *et al.*, 2002). The immunoenriched fraction instead contained mRNA transcripts of genes encoding TPX-1 (a testicular cell adhesion protein essential for the progression of spermatogenesis), PAM (a protein associated with myc), TRF2 (a TATA box-binding protein-like protein involved in transcriptional regulation), GRSF1 (an RNA-binding protein involved in translation initiation), and a few others. All these genes contain a consensus 26-nucleotide sequence (U/A)(A/G)UU(C/U)AGUA(U/A)AANAACUUU(G/U)GAA(U/A)U(G/A) in their 3' UTRs that appears to be both necessary and sufficient for mDAZL binding. This consensus sequence is present in the 3' UTR of *Cdc25A*, but not of *Cdc25C*. A glutathione-S-transferase (GST)-mDAZL fusion protein also selectively captured *Cdc25A*, but not *Cdc25C*, RNA transcripts in mouse testis extracts. Thus, it is not settled whether *Cdc25A* or *Cdc25C*, or neither, is the natural RNA substrate of DAZL.

According to SELEX, the zebrafish DAZL binds the sequence GUUC, which is present in the 3' UTRs of both *Cdc25* and *zDAZL* (Maegawa *et al.*, 2002). Finally, working on the hypothesis that DAZL binds RNA along with its interacting protein PUMILIO-2 (PUM2), Fox *et al.* (2005) isolated mRNAs that bound *in vitro* with both DAZL and PUM2, and identified a complete, different set of 61 genes that are involved in various cellular processes and pathways. For most of the candidate RNA targets identified, characterization was limited to RNA–protein interaction. Additional studies are required to verify that the expression of these target genes is in fact altered in the absence of DAZL, as in the *Dazl*-null mutant mice.

A different approach to studying the function(s) of the DAZ proteins and the underlying mechanisms is through their interacting proteins. The yeast two-hybrid system first revealed that the DAZ proteins interact and have the potential to form homodimers and heterodimers (Ruggiu and Cooke, 2000; Xu *et al.*, 2001). In fact, the human *BOULE* gene was originally isolated by the two-hybrid system using DAZ as bait (Xu *et al.*, 2001). The system also identified several DAZ/DAZL-interacting proteins, including DAZAP1 (DAZ associated protein 1), DAZAP2, DZIP (DAZ interaction protein 1),

PUM2, and hQK3 (Tsui *et al.*, 2000a; Xu *et al.*, 2001; Moore *et al.*, 2003; Moore *et al.*, 2004).

DAZAP1 is an RNA-binding protein that is abundantly present in the nuclei of germ cells from late pachytene spermatocytes through round spermatids, and that translocates to the cytoplasm in elongating spermatids (Tsui *et al.*, 2000b; Dai *et al.*, 2001; Vera *et al.*, 2002). It has the ability to shuttle between the nucleus and cytoplasm, and may be involved in mRNA transport and localization (Kurihara *et al.*, 2004; Lin *et al.*, unpublished data). The DAZAP1 ortholog in *Xenopus*, Prpp (praline-rich RNA-binding protein), binds to the localization element of *Vg1* mRNA, interacts with proteins that are associated with the microfilament, and may be involved in the anchoring of *Vg1* mRNA to the vegetal cortex (Zhao *et al.*, 2001). *DAZAP2* is ubiquitously expressed, and its mouse ortholog *Prtb* (proline codon-rich transcript, brain-expressed) can be deleted without causing any obvious abnormalities (Tsui *et al.*, 2000a; Yang and Mansour, 1999).

DZIP is expressed most abundantly in the testis, and encodes at least three protein isoforms that contain a C2H2 zinc-finger domain (Moore *et al.*, 2004). The *DZIP* proteins have a similar localization in fetal and adult germ cells as *DAZ/DAZL*, except that it shows a unique U-shaped pattern in the cytoplasm of spermatocytes. *PUM2* contains eight pumilio-like repeats, and is a member of the PUF family of RNA-binding proteins that bind to related sequence motifs in the 3' UTR and that repress the translation of their target mRNAs (Moore *et al.*, 2003). *PUM2* is expressed in embryonic stem cells and germ cells, and its localization is similar to that of *DAZ* and *DAZL*. Its orthologs in *Drosophila* and *C. elegans* have been shown to regulate the translation of several mRNAs during the establishment of the germ cell lineage (de Moor *et al.*, 2005). *hQK3* belongs to the quaking protein family of RNA-binding proteins that have been linked to signal transduction pathways (Vernet and Artzt, 1997). The significance of the interaction between these proteins and the *DAZ* proteins remains to be elucidated.

Another approach to studying the functions of the *DAZ* proteins is to identify genes, the expression of which is altered by their absence. A comparison of testis expression profiles of wild-type and *Dazl*-null mutants showed that, although the germ cells in the mutant mice can develop and reach the leptotene–zygotene stage, *DAZL* deficiency affects germ cell gene

expression as early as 5 days after birth when only type A spermatogonia are present (Maratou *et al.*, 2004). Over 30 genes were differentially expressed, and several of them — including metallothionein 2 (*Mt2*), ferritin heavy polypeptide-like 17 (*Fthl17*), nuclear RNA export factor 2 (*Nxf2*), testis expressed gene 14 (*Tex14*), and testis expressed gene 19 (*Tex19*) — exhibited more than a fivefold difference. As noted above, DAZL is predominantly present in the nuclei of type A spermatogonia. Whether it is directly involved in the transcription of these genes remains to be determined.

Conclusion

The *RBMV* and *DAZ* genes were isolated over a decade ago. Through the combined efforts of numerous laboratories around the world, their structures and expression patterns, as well as the molecular mechanisms underlying their deletions, are now well defined. We also have a general idea about the biological functions of their protein products. However, most of the functional analyses were performed on their autosomal or X-linked homologs, which have quite different amino acid sequences. In addition, results obtained from the *in vitro* systems may not reflect the *in vivo* situations, where *RBMV* and *DAZ* are likely to interact with other germ cell-specific proteins in carrying out their functions. The identities of the downstream targets of *RBMV* and *DAZ* remain unclear. The restriction of *DAZ* to the primate lineage and the lack of established primate germ cell lines that express *RBMV* and/or *DAZ* further hinder the functional analysis of these proteins.

References

- Calogero, A. E., Garofalo, M. R., Barone, N., Longo, G. A., De Palma, A., Fichera, M., Rappazzo, G., D'Agata, R., and Vicari, E. (2002). Spontaneous transmission from a father to his son of a Y chromosome microdeletion involving the deleted in azoospermia (*DAZ*) gene. *J Endocrinol Invest* **25**, 631–634.
- Chai, N. N., Salido, E. C., and Yen, P. H. (1997). Multiple functional copies of the *RBM* gene family, a spermatogenesis candidate on the human Y chromosome. *Genomics* **45**, 355–361.
- Chandley, A. C., and Cooke, H. J. (1994). Human male fertility — Y-linked genes and spermatogenesis. *Hum Mol Genet* **3**, 1449–1452.
- Chang, P. L., Sauer, M. V., and Brown, S. (1999). Y chromosome microdeletion in a father and his four infertile sons. *Hum Reprod* **14**, 2689–2694.

- Chen, C., Ouyang, W., Grigura, V., Zhou, Q., Carnes, K., Lim, H., Zhao, G. Q., Arber, S., Kurpios, N., Murphy, T. L., *et al.* (2005). ERM is required for transcriptional control of the spermatogonial stem cell niche. *Nature* **436**, 1030–1034.
- Cheng, M. H., Maines, J. Z., and Wasserman, S. A. (1998). Biphasic subcellular localization of the DAZL-related protein boule in *Drosophila* spermatogenesis. *Dev Biol* **204**, 567–576.
- Collier, B., Gorgoni, B., Loveridge, C., Cooke, H. J., and Gray, N. K. (2005). The DAZL family proteins are PABP-binding proteins that regulate translation in germ cells. *EMBO J* **24**, 2656–2666.
- Dai, T., Vera, Y., Salido, E. C., and Yen, P. H. (2001). Characterization of the mouse Dazap1 gene encoding an RNA-binding protein that interacts with infertility factors DAZ and DAZL. *BMC Genomics* **2**, 6.
- de Moor, C. H., Meijer, H., and Lissenden, S. (2005). Mechanisms of translational control by the 3' UTR in development and differentiation. *Semin Cell Dev Biol* **16**, 49–58.
- de Vries, J. W., Repping, S., van Daalen, S. K., Korver, C. M., Leschot, N. J., and van der Veen, F. (2002). Clinical relevance of partial AZFc deletions. *Fertil Steril* **78**, 1209–1214.
- Delbridge, M. L., Lingenfelter, P. A., Disteché, C. M., and Graves, J. A. (1999). The candidate spermatogenesis gene RBMY has a homologue on the human X chromosome. *Nat Genet* **22**, 223–224.
- Dorfman, D. M., Genest, D. R., and Reijo Pera, R. A. (1999). Human DAZL1 encodes a candidate fertility factor in women that localizes to the prenatal and postnatal germ cells. *Hum Reprod* **14**, 2531–2536.
- Eberhart, C. G., Maines, J. Z., and Wasserman, S. A. (1996). Meiotic cell cycle requirement for a fly homologue of human deleted in azoospermia. *Nature* **381**, 783–785.
- Elliott, D. J. (2004). The role of potential splicing factors including RBMY, RBMX, hnRNP-G-T and STAR proteins in spermatogenesis. *Int J Androl* **27**, 328–334.
- Elliott, D. J., Ma, K., Kerr, S. M., Thakrar, R., Speed, R., Chandley, A. C., and Cooke, H. (1996). An RBM homologue maps to the mouse Y chromosome and is expressed in germ cells. *Hum Mol Genet* **5**, 869–874.
- Elliott, D. J., Millar, M. R., Oghene, K., Ross, A., Kiesewetter, F., Pryor, J., McIntyre, M., Hargreave, T. B., Saunders, P. T., Vogt, P. H., *et al.* (1997). Expression of RBM in the nuclei of human germ cells is dependent on a critical region of the Y chromosome long arm. *Proc Natl Acad Sci U S A* **94**, 3848–3853.
- Elliott, D. J., Oghene, K., Makarov, G., Makarova, O., Hargreave, T. B., Chandley, A. C., Eperon, I. C., and Cooke, H. J. (1998). Dynamic changes in the subnuclear organisation of pre-mRNA splicing proteins and RBM during human germ cell development. *J Cell Sci* **111**, 1255–1265.
- Elliott, D. J., Venables, J. P., Newton, C. S., Lawson, D., Boyle, S., Eperon, I. C., and Cooke, H. J. (2000). An evolutionarily conserved germ cell-specific hnRNP is encoded by a retrotransposed gene. *Hum Mol Genet* **9**, 2117–2124.
- Ferlin, A., Tessari, A., Ganz, F., Marchina, E., Barlati, S., Garolla, A., Engl, B., and Foresta, C. (2005). Association of partial AZFc region deletions with spermatogenic impairment and male infertility. *J Med Genet* **42**, 209–213.
- Fernandes, S., Huellen, K., Goncalves, J., Dukal, H., Zeisler, J., Rajpert-De Meyts, E., Skakkebaek, N. E., Habermann, B., Krause, W., Sousa, M., *et al.* (2002). High frequency

- of DAZ1/DAZ2 gene deletions in patients with severe oligozoospermia. *Mol Hum Reprod* **8**, 286–298.
- Fernandes, S., Paracchini, S., Meyer, L. H., Florida, G., Tyler-Smith, C., and Vogt, P. H. (2004). A large AZFc deletion removes DAZ3/DAZ4 and nearby genes from men in Y haplogroup N. *Am J Hum Genet* **74**, 180–187.
- Fox, M., Urano, J., and Reijo Pera, R. A. (2005). Identification and characterization of RNA sequences to which human PUMILIO-2 (PUM2) and deleted in azoospermia-like (DAZL) bind. *Genomics* **85**, 92–105.
- Gromoll, J., Weinbauer, G. F., Skaletsky, H., Schlatt, S., Rocchietti-March, M., Page, D. C., and Nieschlag, E. (1999). The Old World monkey DAZ (deleted in azoospermia) gene yields insights into the evolution of the DAZ gene cluster on the human Y chromosome. *Hum Mol Genet* **8**, 2017–2024.
- Haag, E. S. (2001). Rolling back to BOULE. *Proc Natl Acad Sci U S A* **98**, 6983–6985.
- Hashimoto, Y., Maegawa, S., Nagai, T., Yamaha, E., Suzuki, H., Yasuda, K., and Inoue, K. (2004). Localized maternal factors are required for zebrafish germ cell formation. *Dev Biol* **268**, 152–161.
- Hofmann, Y., and Wirth, B. (2002). hnRNP-G promotes exon 7 inclusion of survival motor neuron (SMN) via direct interaction with Htra2-beta 1. *Hum Mol Genet* **11**, 2037–2049.
- Houston, D. W., and King, M. L. (2000). A critical role for Xdazl, a germ plasm-localized RNA, in the differentiation of primordial germ cells in *Xenopus*. *Development* **127**, 447–456.
- Houston, D. W., Zhang, J., Maines, J. Z., Wasserman, S. A., and King, M. L. (1998). A *Xenopus* DAZ-like gene encodes an RNA component of germ plasm and is a functional homologue of *Drosophila* boule. *Development* **125**, 171–180.
- Hucklenbroich, K., Gromoll, J., Heinrich, M., Hohoff, C., Nieschlag, E., and Simoni, M. (2005). Partial deletions in the AZFc region of the Y chromosome occur in men with impaired as well as normal spermatogenesis. *Hum Reprod* **20**, 191–197.
- Jiao, X., Trifillis, P., and Kiledjian, M. (2002). Identification of target messenger RNA substrates for the murine deleted in azoospermia-like RNA-binding protein. *Biol Reprod* **66**, 475–485.
- Jobling, M. A., Samara, V., Pandya, A., Fretwell, N., Bernasconi, B., Mitchell, R. J., Gerel-saikhan, T., Dashnyam, B., Sajantila, A., Salo, P. J., *et al.* (1996). Recurrent duplication and deletion polymorphisms on the long arm of the Y chromosome in normal males. *Hum Mol Genet* **5**, 1767–1775.
- Johnson, A. D., Bachvarova, R. F., Drum, M., and Masi, T. (2001). Expression of axolotl DAZL RNA, a marker of germ plasm: widespread maternal RNA and onset of expression in germ cells approaching the gonad. *Dev Biol* **234**, 402–415.
- Johnson, J., Bagley, J., Skaznik-Wikiel, M., Lee, H. J., Adams, G. B., Niikura, Y., Tschudy, K. S., Tilly, J. C., Cortes, M. L., Forkert, R., *et al.* (2005). Oocyte generation in adult mammalian ovaries by putative germ cells in bone marrow and peripheral blood. *Cell* **122**, 303–315.
- Kamp, C., Hirschmann, P., Voss, H., Huellen, K., and Vogt, P. H. (2000). Two long homologous retroviral sequence blocks in proximal Yq11 cause AZFa microdeletions as a result of intrachromosomal recombination events. *Hum Mol Genet* **9**, 2563–2572.
- Kanaar, R., Lee, A. L., Rudner, D. Z., Wemmer, D. E., and Rio, D. C. (1995). Interaction of the sex-lethal RNA binding domains with RNA. *EMBO J* **14**, 4530–4539.

- Karashima, T., Sugimoto, A., and Yamamoto, M. (2000). Caenorhabditis elegans homologue of the human azoospermia factor DAZ is required for oogenesis but not for spermatogenesis. *Development* **127**, 1069–1079.
- Krausz, C., Forti, G., and McElreavey, K. (2003). The Y chromosome and male fertility and infertility. *Int J Androl* **26**, 70–75.
- Kuhnert, B., Gromoll, J., Kostova, E., Tschanter, P., Luetjens, C. M., Simoni, M., and Nieschlag, E. (2004). Case report: natural transmission of an AZFc Y-chromosomal microdeletion from father to his sons. *Hum Reprod* **19**, 886–888.
- Kurihara, Y., Watanabe, H., Kawaguchi, A., Hori, T., Mishiro, K., Ono, M., Sawada, H., and Uesugi, S. (2004). Dynamic changes in intranuclear and subcellular localizations of mouse Prpp/DAZAP1 during spermatogenesis: the necessity of the C-terminal proline-rich region for nuclear import and localization. *Arch Histol Cytol* **67**, 325–333.
- Kuroda-Kawaguchi, T., Skaletsky, H., Brown, L. G., Minx, P. J., Cordum, H. S., Waterston, R. H., Wilson, R. K., Silber, S., Oates, R., Rozen, S., et al. (2001). The AZFc region of the Y chromosome features massive palindromes and uniform recurrent deletions in infertile men. *Nat Genet* **29**, 279–286.
- Lin, Y. W., Thi, D. A., Kuo, P. L., Hsu, C. C., Huang, B. D., Yu, Y. H., Vogt, P. H., Krause, W., Ferlin, A., Foresta, C., et al. (2005). Polymorphisms associated with the DAZ genes on the human Y chromosome. *Genomics* **86**, 431–438.
- Lynch, M., Cram, D. S., Reilly, A., O'Bryan, M. K., Baker, H. W., de Kretser, D. M., and McLachlan, R. (2005). The Y chromosome gr/gr subdeletion is associated with male infertility. *Mol Hum Reprod* **11**, 507–512.
- Ma, K., Inglis, J. D., Sharkey, A., Bickmore, W. A., Hill, R. E., Prosser, E. J., Speed, R. M., Thomson, E. J., Jobling, M., Taylor, K., Wolfe, J., et al. (1993). A Y chromosome gene family with RNA-binding protein homology: candidates for the azoospermia factor AZF controlling human spermatogenesis. *Cell* **75**, 1287–1295.
- Machev, N., Saut, N., Longepied, G., Terriou, P., Navarro, A., Levy, N., Guichaoua, M., Metzler-Guillemain, C., Collignon, P., Frances, A. M., et al. (2004). Sequence family variant loss from the AZFc interval of the human Y chromosome, but not gene copy loss, is strongly associated with male infertility. *J Med Genet* **41**, 814–825.
- Maegawa, S., Yamashita, M., Yasuda, K., and Inoue, K. (2002). Zebrafish DAZ-like protein controls translation via the sequence 'GUUC'. *Genes Cells* **7**, 971–984.
- Maegawa, S., Yasuda, K., and Inoue, K. (1999). Maternal mRNA localization of zebrafish DAZ-like gene. *Mech Dev* **81**, 223–226.
- Mahadevaiah, S. K., Odoriso, T., Elliott, D. J., Rattigan, A., Szot, M., Laval, S. H., Washburn, L. L., McCarrey, J. R., Cattanach, B. M., Lovell-Badge, R., et al. (1998). Mouse homologues of the human AZF candidate gene RBM are expressed in spermatogonia and spermatids, and map to a Y chromosome deletion interval associated with a high incidence of sperm abnormalities. *Hum Mol Genet* **7**, 715–727.
- Maines, J. Z., and Wasserman, S. A. (1999). Post-transcriptional regulation of the meiotic Cdc25 protein twine by the Dazl orthologue boule. *Nat Cell Biol* **1**, 171–174.
- Maratou, K., Forster, T., Costa, Y., Taggart, M., Speed, R. M., Ireland, J., Teague, P., Roy, D., and Cooke, H. J. (2004). Expression profiling of the developing testis in wild-type and Dazl knockout mice. *Mol Reprod Dev* **67**, 26–54.
- Mazeyrat, S., Saut, N., Mattei, M. G., and Mitchell, M. J. (1999). RBMY evolved on the Y chromosome from a ubiquitously transcribed X-Y identical gene. *Nat Genet* **22**, 224–226.

- Mita, K., and Yamashita, M. (2000) Expression of *Xenopus* Daz-like protein during gametogenesis and embryogenesis. *Mech Dev* **94**, 251–255.
- Mizoguchi, S., and Kim, K. H. (1997). Expression of *cdc25* phosphatases in the germ cells of the rat testis. *Biol Reprod* **56**, 1474–1481.
- Moore, F. L., Jaruzelska, J., Dorfman, D. M., and Reijo-Pera, R. A. (2004). Identification of a novel gene, DZIP (DAZ-interacting protein), that encodes a protein that interacts with DAZ (deleted in azoospermia) and is expressed in embryonic stem cells and germ cells. *Genomics* **83**, 834–843.
- Moore, F. L., Jaruzelska, J., Fox, M. S., Urano, J., Firpo, M. T., Turek, P. J., Dorfman, D. M., and Pera, R. A. (2003). Human Pumilio-2 is expressed in embryonic stem cells and germ cells and interacts with DAZ (deleted in azoospermia) and DAZ-like proteins. *Proc Natl Acad Sci U S A* **100**, 538–543.
- Nasim, M. T., Chernova, T. K., Chowdhury, H. M., Yue, B. G., and Eperon, I. C. (2003). HnRNP G and Tra2beta: opposite effects on splicing matched by antagonism in RNA binding. *Hum Mol Genet* **12**, 1337–1348.
- Nishi, S., Hoshi, N., Kasahara, M., Ishibashi, T., and Fujimoto, S. (1999). Existence of human DAZLA protein in the cytoplasm of human oocytes. *Mol Hum Reprod* **5**, 495–497.
- Osterlund, C., Stabi, B., Bhasin, S., Kvist, U., Pousette, A., and Arver, S. (2001). Specific localization of RBM1a in the nuclei of all cell types except elongated spermatids within seminiferous tubules of the human. *Int J Androl* **24**, 272–277.
- Page, D. C. (2004). 2003 Curt Stern Award address. On low expectation exceeded; or, the genomic salvation of the Y chromosome. *Am J Hum Genet* **74**, 399–402.
- Reijo, R., Lee, T. Y., Salo, P., Alagappan, R., Brown, L. G., Rosenberg, M., Rozen, S., Jaffe, T., Straus, D., Hovatta, O., *et al.* (1995). Diverse spermatogenic defects in humans caused by Y chromosome deletions encompassing a novel RNA-binding protein gene. *Nat Genet* **10**, 383–393.
- Reijo, R. A., Dorfman, D. M., Slee, R., Renshaw, A. A., Loughlin, K. R., Cooke, H., and Page, D. C. (2000). DAZ family proteins exist throughout male germ cell development and transit from nucleus to cytoplasm at meiosis in humans and mice. *Biol Reprod* **63**, 1490–1496.
- Repping, S., Skaletsky, H., Brown, L., van Daalen, S. K., Korver, C. M., Pyntikova, T., Kuroda-Kawaguchi, T., de Vries, J. W., Oates, R. D., Silber, S., *et al.* (2003). Polymorphism for a 1.6-Mb deletion of the human Y chromosome persists through balance between recurrent mutation and haploid selection. *Nat Genet* **35**, 247–251.
- Repping, S., Skaletsky, H., Lange, J., Silber, S., van der Veen, F., Oates, R. D., Page, D. C., and Rozen, S. (2002). Recombination between palindromes P5 and P1 on the human Y chromosome causes massive deletions and spermatogenic failure. *Am J Hum Genet* **71**, 906–922.
- Repping, S., van Daalen, S. K., Korver, C. M., Brown, L. G., Marszalek, J. D., Gianotten, J., Oates, R. D., Silber, S., van der Veen, F., Page, D. C., *et al.* (2004). A family of human Y chromosomes has dispersed throughout northern Eurasia despite a 1.8-Mb deletion in the azoospermia factor c region. *Genomics* **83**, 1046–1052.
- Reynolds, N., and Cooke, H. J. (2005). Role of the DAZ genes in male fertility. *Reprod Biomed Online* **10**, 72–80.
- Ruggiu, M., and Cooke, H. J. (2000). In vivo and in vitro analysis of homodimerisation activity of the mouse Dazl1 protein. *Gene* **252**, 119–126.

- Ruggiu, M., Speed, R., Taggart, M., McKay, S. J., Kilanowski, F., Saunders, P., Dorin, J., and Cooke, H. J. (1997). The mouse Dazla gene encodes a cytoplasmic protein essential for gametogenesis. *Nature* **389**, 73–77.
- Saunders, P. T., Turner, J. M., Ruggiu, M., Taggart, M., Burgoyne, P. S., Elliott, D., and Cooke, H. J. (2003). Absence of mDazl produces a final block on germ cell development at meiosis. *Reproduction* **126**, 589–597.
- Saut, N., Terriou, P., Navarro, A., Levy, N., and Mitchell, M. J. (2000). The human Y chromosome genes BPY2, CDY1 and DAZ are not essential for sustained fertility. *Mol Hum Reprod* **6**, 789–793.
- Saxena, R., Brown, L. G., Hawkins, T., Alagappan, R. K., Skaletsky, H., Reeve, M. P., Reijo, R., Rozen, S., Dinulos, M. B., Disteche, C. M., *et al.* (1996). The DAZ gene cluster on the human Y chromosome arose from an autosomal gene that was transposed, repeatedly amplified and pruned. *Nat Genet* **14**, 292–299.
- Saxena, R., de Vries, J. W., Repping, S., Alagappan, R. K., Skaletsky, H., Brown, L. G., Ma, P., Chen, E., Hoovers, J. M., and Page, D. C. (2000). Four DAZ genes in two clusters found in the AZFc region of the human Y chromosome. *Genomics* **67**, 256–267.
- Seboun, E., Barbaux, S., Bourgeron, T., Nishi, S., Agulnik, A., Egashira, M., Nikkawa, N., Bishop, C., Fellous, M., McElreavey, K., *et al.* (1997). Gene sequence, localization, and evolutionary conservation of DAZLA, a candidate male sterility gene. *Genomics* **15**, 227–235.
- Seligman, J., and Page, D. C. (1998). The Dazh gene is expressed in male and female embryonic gonads before germ cell sex differentiation. *Biochem Biophys Res Commun* **245**, 878–882.
- Skaletsky, H., Kuroda-Kawaguchi, T., Minx, P. J., Cordum, H. S., Hillier, L., Brown, L. G., Repping, S., Pyntikova, T., Ali, J., Bieri, T., Chinwalla, A., *et al.* (2003). The male-specific region of the human Y chromosome is a mosaic of discrete sequence classes. *Nature* **423**, 825–837.
- Slee, R., Grimes, B., Speed, R. M., Taggart, M., Maguire, S. M., Ross, A., McGill, N. I., Saunders, P. T., and Cooke, H. J. (1999). A human DAZ transgene confers partial rescue of the mouse Dazl null phenotype. *Proc Natl Acad Sci U S A* **96**, 8040–8045.
- Soulard, M., Della Valle, V., Siomi, M. C., Pinol-Roma, S., Codogno, P., Bauvy, C., Bellini, M., Lacroix, J. C., Monod, G., Dreyfuss, G., *et al.* (1993). hnRNP G: sequence and characterization of a glycosylated RNA-binding protein. *Nucleic Acids Res* **21**, 4210–4217.
- Sun, C., Skaletsky, H., Rozen, S., Gromoll, J., Nieschlag, E., Oates, R., and Page, D. C. (2000). Deletion of azoospermia factor a (AZFa) region of human Y chromosome caused by recombination between HERV15 proviruses. *Hum Mol Genet* **9**, 2291–2296.
- Szot, M., Grigoriev, V., Mahadevaiah, S. K., Ojarikre, O. A., Toure, A., von Glasenapp, E., Rattigan, A., Turner, J. M., Elliott, D. J., and Burgoyne, P. S. (2003). Does Rbmy have a role in sperm development in mice? *Cytogenet Genome Res* **103**, 330–336.
- Tiepolo, L., and Zuffardi, O. (1976). Localization of factors controlling spermatogenesis in the nonfluorescent portion of the human Y chromosome long arm. *Hum Genet* **34**, 119–124.
- Tsend-Ayush, E., O'Sullivan, L. A., Grutzner, F. S., Onnebo, S. M., Lewis, R. S., Delbridge, M. L., Marshall Graves, J. A., and Ward, A. C. (2005). RBMX gene is essential for brain development in zebrafish. *Dev Dyn* **234**, 682–688.

- Tsuei, D. J., Hsu, H. C., Lee, P. H., Jeng, Y. M., Pu, Y. S., Chen, C. N., Lee, Y. C., Chou, W. C., Chang, C. J., Ni, Y. H., *et al.* (2004). RBMY, a male germ cell-specific RNA-binding protein, activated in human liver cancers and transforms rodent fibroblasts. *Oncogene* **23**, 5815–5822.
- Tsui, S., Dai, T., Roettger, S., Schempp, W., Salido, E. C., and Yen, P. H. (2000a). Identification of two novel proteins that interact with germ-cell-specific RNA-binding proteins DAZ and DAZL1. *Genomics* **65**, 266–273.
- Tsui, S., Dai, T., Warren, S. T., Salido, E. C., and Yen, P. H. (2000b). Association of the mouse infertility factor DAZL1 with actively translating polyribosomes. *Biol Reprod* **62**, 1655–1660.
- Turner, J. M., Mahadevaiah, S. K., Elliott, D. J., Garchon, H. J., Pehrson, J. R., Jaenisch, R., and Burgoyne, P. S. (2002). Meiotic sex chromosome inactivation in male mice with targeted disruptions of Xist. *J Cell Sci* **115**, 4097–4105.
- Venables, J. P., Elliott, D. J., Makarova, O. V., Makarov, E. M., Cooke, H. J., and Eperon, I. C. (2000). RBMY, a probable human spermatogenesis factor, and other hnRNP G proteins interact with Tra2beta and affect splicing. *Hum Mol Genet* **9**, 685–694.
- Venables, J. P., Ruggiu, M., and Cooke, H. J. (2001). The RNA-binding specificity of the mouse Dazl protein. *Nucleic Acids Res* **29**, 2479–2483.
- Venables, J. P., Vernet, C., Chew, S. L., Elliott, D. J., Cowmeadow, R. B., Wu, J., Cooke, H. J., Artzt, K., and Eperon, I. C. (1999). T-STAR/ETOILE: a novel relative of SAM68 that interacts with an RNA-binding protein implicated in spermatogenesis. *Hum Mol Genet* **8**, 959–969.
- Vera, Y., Dai, T., Hikim, A. P., Lue, Y., Salido, E. C., Swerdloff, R. S., and Yen, P. H. (2002). Deleted in azoospermia associated protein 1 shuttles between nucleus and cytoplasm during normal germ cell maturation. *J Androl* **23**, 622–628.
- Vernet, C., and Artzt, K. (1997). STAR, a gene family involved in signal transduction and activation of RNA. *Trends Genet* **13**, 479–484.
- Vogt, P. H., Edelmann, A., Kirsch, S., Henegariu, O., Hirschmann, P., Kiesewetter, F., Kohn, F. M., Schill, W. B., Farah, S., Ramos, C., *et al.* (1996). Human Y chromosome azoospermia factors (AZF) mapped to different subregions in Yq11. *Hum Mol Genet* **5**, 933–943.
- Wu, S., and Wolgemuth, D. J. (1995). The distinct and developmentally regulated patterns of expression of members of the mouse Cdc25 gene family suggest differential functions during gametogenesis. *Dev Biol* **170**, 195–206.
- Xu, E. Y., Lee, D. F., Klebes, A., Turek, P. J., Kornberg, T. B., and Reijo Pera, R. A. (2003). Human BOULE gene rescues meiotic defects in infertile flies. *Hum Mol Genet* **12**, 169–175.
- Xu, E. Y., Moore, F. L., and Pera, R. A. (2001). A gene family required for human germ cell development evolved from an ancient meiotic gene conserved in metazoans. *Proc Natl Acad Sci U S A* **98**, 7414–7419.
- Yang, W., and Mansour, S. L. (1999). Expression and genetic analysis of prtb, a gene that encodes a highly conserved proline-rich protein expressed in the brain. *Dev Dyn* **215**, 108–116.
- Yen, P. H. (1999). Advances in Y chromosome mapping. *Curr Opin Obstet Gynecol* **11**, 275–281.
- Yen, P. H. (2004). Putative biological functions of the DAZ family. *Int J Androl* **27**, 125–129.

- Yen, P. H., Chai, N. N., and Salido, E. C. (1997). The human DAZ genes, a putative male infertility factor on the Y chromosome, are highly polymorphic in the DAZ repeat regions. *Mamm Genome* **8**, 756–759.
- Zhao, W. M., Jiang, C., Kroll, T. T., and Huber, P. W. (2001). A proline-rich protein binds to the localization element of *Xenopus* Vg1 mRNA and to ligands involved in actin polymerization. *EMBO J* **20**, 2315–2325.

CHAPTER 7

NEUROTROPHIC FACTORS IN THE DEVELOPMENT OF THE POSTNATAL MALE GERM LINE

Marie-Claude Hofmann and Laura Braydich-Stolle

*Department of Biology, Sciences Center,
University of Dayton, 300 College Park,
Dayton, OH 45469*

Neurotrophic factors were originally defined as paracrine molecules that promote the survival, differentiation, and repair of embryonic or adult neuronal cells. These factors include neurotrophins, neuropoietic cytokines, and the GDNF family of neurotrophic factors. Data recently obtained with transgenic and knockout mice revealed that neurotrophic factors and their receptors are also expressed in many organs outside the nervous system, and play an important role in embryonic development and in the maintenance of adult tissues. This review focuses on the role of neurotrophic factors in the development and maintenance of the male germ line after birth. Emphasis is given to glial cell line-derived neurotrophic factor (GDNF), some of the signaling molecules recently discovered downstream of the Ret receptor, and the cooperation between GDNF and other juxtacrine and paracrine factors.

Keywords: Neurotrophic factors; spermatogenesis; spermatogonia; stem cells; signal transduction.

Introduction

Spermatogenesis is a complex and tightly regulated process in which male germ line stem cells develop to ultimately form spermatozoa. In the mammalian testis, the development of the germ line after birth involves four distinct events: stem cell self-renewal that maintains the continuous production of germ cells throughout life; spermatogonial proliferation and differentiation that amplifies the number of premeiotic cells; meiosis in

Corresponding author: Marie-Claude Hofmann; e-mail: Marie-Claude.Hofmann@notes.udayton.edu

spermatocytes; and spermiogenesis, which is the morphological differentiation of round spermatids into spermatozoa.

Stem cells and their direct progeny reside in the basal part of the germinal epithelium, in contact with the basement membrane. Male germ line stem cells are also called A_{single} spermatogonia, or spermatogonial stem cells (SSCs). They are cells with undifferentiated morphology that are not connected by intercellular bridges like the more advanced germ cells (Huckins, 1971; Oakberg, 1971; Dym and Fawcett, 1971; de Rooij and Russell, 2000). According to the model of Huckins and Oakberg (1978), A_{single} spermatogonia can renew themselves or differentiate into A_{paired} spermatogonia, which remain connected by an intercellular bridge. The A_{paired} spermatogonia further divide to form chains of 4, 8, or 16 A_{aligned} (A_{al}) spermatogonia. The A_{aligned} cells then differentiate into type A_1 spermatogonia, which resume division to form A_2 to A_4 spermatogonia. Next, A_4 cells divide to form intermediate (In) spermatogonia, which in turn divide to produce type B spermatogonia. Finally, type B spermatogonia divide to form primary spermatocytes, which enter meiosis and further develop into haploid spermatids and sperm.

The molecular mechanisms that drive the different events of spermatogenesis are still poorly understood; in particular, the cues that mediate the decision of spermatogonial stem cells to self-renew or differentiate are not elucidated. Nonetheless, it is now understood that spermatogenesis is the result of a complex interplay of proliferation, inductive events, and differentiation regulated by cell–cell communications between the testicular somatic cells and the germ cells.

In the seminiferous epithelium, germ cells are in close association with the somatic Sertoli cells, but are protected from the rest of the testicular environment by the blood–testis barrier (Dym and Fawcett, 1970). Thus, only paracrine factors produced by the Sertoli cells can induce or inhibit the proliferation, differentiation, and further development of the germ cells (Skinner, 2005a). Sertoli cells also provide the structural support for the developing germ cells (Russell *et al.*, 1983; Wong and Russell, 1983). Furthermore, communication between Sertoli cells and other testicular somatic cells, such as peritubular myoid cells and interstitial Leydig cells, are necessary for the initiation and maintenance of spermatogenesis (Skinner, 2005a). Peritubular cells surround Sertoli cells and form the exterior wall of the seminiferous tubules. Follicle-stimulating hormone (FSH) from the

pituitary gland and testosterone from Leydig cells regulate the functions of Sertoli cells and ensure the proper development of the germ cells (Griswold, 1998).

Paracrine factors produced by Sertoli cells that regulate germ cell development are numerous, and are also produced in many different tissues (Skinner, 2005a). Recently, the discovery that Sertoli cells secrete paracrine factors that were originally identified in the brain to ensure the differentiation, maintenance, and repair of neurons has provided a considerable advance in our understanding of the regulation of spermatogenesis (Cupp *et al.*, 2000; Meng *et al.*, 2000; Park *et al.*, 2001). This chapter reviews the most relevant of these factors, called neurotrophic factors, for the early postnatal development of the male germ line.

Neurotrophic Factors

Neurotrophic factors were originally defined as paracrine molecules that promote the survival, differentiation, and repair of embryonic or adult neuronal cells. However, it has now become apparent that some of these factors are also active in nonneuronal embryonic tissues, or reactivated in adulthood during tissue renewal or regeneration. Also, evidence is accumulating that a number of multifunctional signaling molecules, such as fibroblast growth factors (FGFs), transforming growth factors (TGFs), and bone morphogenetic proteins (BMPs), act as trophic factors for neurons as well. Nonetheless, neurotrophic factors traditionally include only molecules that preferentially act on neuronal cells or that were originally discovered as anti-apoptotic molecules for neuronal cells. These typical neurotrophic factors are the neurotrophins, the neuropoietic cytokines, and the GDNF family of neurotrophic factors. Although these three families of paracrine factors are well known for their action on the central and peripheral nervous systems, they also play a critical role in the development of the male germ line both in the embryo and in the neonatal and adult testis.

Neurotrophins and their receptors

In mammals, the neurotrophin family of growth factors consists of five members: nerve growth factor (NGF) (Liuzzi *et al.*, 1965), brain-derived neurotrophic factor (BDNF) (Barde *et al.*, 1982; Leibrock *et al.*, 1989), neurotrophin-3 (NT-3) (Hohn *et al.*, 1990; Maisonpierre *et al.*, 1990), and

neurotrophin-4/5 (NT-4/5) (Hallbook *et al.*, 1991; Berkemeier *et al.*, 1991) (for a review see Barbacid, 1995). They share the same low-affinity receptor $p75^{\text{NTR}}$, which is a member of the tumor necrosis factor (TNF) receptor superfamily (Chao *et al.*, 1986; Johnson *et al.*, 1986; Roux and Barker, 2002; Nykjaer *et al.*, 2005). For high-affinity receptor binding, the neurotrophins use different members of the Trk receptor tyrosine kinase family: NGF binds preferentially to TrkA (Klein *et al.*, 1991a), BDNF and NT-4/5 bind to TrkB (Klein *et al.*, 1991b), and NT-3 uses TrkC (Lamballe *et al.*, 1991; Ip *et al.*, 1993) (Fig. 1). The low- and high-affinity neurotrophin receptors are widely distributed in nonneuronal tissues, including the testis (Schultz *et al.*, 2001; Park *et al.*, 2001).

Nerve growth factor (NGF) and its receptors

The expression of NGF in the neonatal and adult testis has been extensively studied (Olson *et al.*, 1987; Ayer-LeLievre *et al.*, 1988; Chen *et al.*, 1997; Cupp *et al.*, 2000). NGF mRNA has been found in mouse and rat

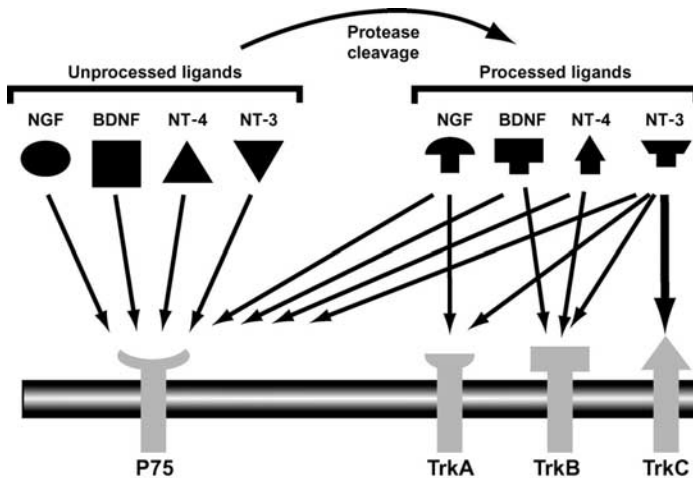

Fig. 1. Neurotrophins and their receptors. Neurotrophins are synthesized as immature forms, and are then processed by protease cleavage into mature ligands. All the unprocessed neurotrophins bind with high affinity to the $p75^{\text{NTR}}$ receptor. The processed neurotrophins also bind to $p75^{\text{NTR}}$, but with lower affinity. The processed forms bind to the Trk receptors: NGF binds to TrkA, BDNF and NT-4/5 bind to TrkB, while NT-3 preferentially binds to TrkC. From Segal (2003).

spermatocytes and early spermatids (Ayer-LeLievre *et al.*, 1988; Chen *et al.*, 1997; Onoda *et al.*, 1991), while the TrkA receptor has been detected in Sertoli cells (Persson *et al.*, 1990). More specifically, the NGF protein is expressed in germ cells from late meiosis to midspemioogenesis, while the TrkA receptor is present only in Sertoli cells during stages VII and VIII. NGF also stimulates DNA synthesis in seminiferous tubule segments containing preleptotene spermatocytes (Parvinen *et al.*, 1992). Altogether, these results suggest a paracrine role of NGF at the onset of meiosis.

More recently, Cupp and colleagues also detected NGF produced by Sertoli cells in the embryo and perinatally, which suggested that TrkA might be expressed by developing germ cells at these stages of development (Cupp *et al.*, 2000). Indeed, further studies with *TrkA* knockout mice indicated an alteration in germ cell numbers and an increase in spermatocyte apoptosis on postnatal day 19 (Cupp *et al.*, 2002). This is in contrast to the situation in the adult seminiferous tubules, where TrkA expression is not detectable, at least by *in situ* hybridization (Schultz *et al.*, 2001). Surprisingly, in animals treated with hCG (LH), an induction of TrkA could be seen in preleptotene and primary pachytene spermatocytes after 12 hours of treatment (Schultz *et al.*, 2001). This suggests that TrkA expression might be under direct control of the hypothalamic-pituitary-testicular axis, and that LH indirectly mediates the effect of NGF on germ cells.

Brain-derived neurotrophic factor (BDNF) and its receptors

The expression of BDNF and its high-affinity receptor TrkB during spermatogenesis has been thoroughly studied by Park *et al.* (2001). RT-PCR analysis of BDNF and TrkB was performed on mice testes at different ages ranging from 6 days old to adult. Using primers designed for the *trkB* tyrosine kinase domain, *trkB* mRNA was detected in all samples tested. Immunohistochemistry analysis for TrkB revealed expression of the receptor in types A and B spermatogonia, whereas little immunoreactivity was detected from spermatocytes to haploid cells in the 18-day-old and adult mice testes. Since there are several alternatively spliced *trkB* mRNAs that do not contain the cytoplasmic tyrosine kinase domain (Klein *et al.*, 1990), the expression and the localization of mRNA containing the TrkB extracellular domain were also investigated by *in situ* hybridization analysis. The result

indicated that the TrkB-truncated receptor was expressed by the peritubular myoid cells and Leydig cells; some weak labeling was also found in spermatogonia. This implies that the TrkB isoform in these cells do not transduce the BDNF signal, or might work as a scavenger and sequester BDNF from extratubular origin (Park *et al.*, 2001; Sariola, 2001).

The BDNF gene consists of five exons, and produces at least eight different transcripts with sizes between 1.6 and 4 kb (Ohara *et al.*, 1992; Timmusk *et al.*, 1993b). Different transcripts are expressed by different cell types (neuronal cells, muscle cells, or astrocytes), or might depend on specific environmental cues (Timmusk *et al.*, 1993b). In the testis, the expression of each type of BDNF transcript is developmentally regulated, although the total expression level of BDNF transcripts remains constant (Park *et al.*, 2001). Immunohistochemistry analysis revealed that BDNF is mostly produced by Sertoli cells in the 18-day-old and adult mouse testis. This complements the observations of Cupp *et al.* (2000), who did not identify BDNF in the embryonic and postnatal testis. Taken together, these results indicate that BDNF, produced by Sertoli cells in the adult testis, might influence spermatogonial development and differentiation.

Neurotrophin-3 (NT-3) and its receptors

Neurotrophin-3 is now recognized as an essential Sertoli cell product during embryonic testis development, where it promotes cord formation and germ cell survival (Cupp *et al.*, 2000; Levine *et al.*, 2000; Skinner, 2005b). After birth, NT-3 is not expressed by Sertoli cells in the prepubertal testis. Park and colleagues detected NT-3 expression in the mouse testis starting at day 18 after birth and in the adult testis using Northern blot analysis (Park *et al.*, 2001). They confirmed via immunocytochemistry that the growth factor was produced mainly by spermatocytes. The high-affinity receptor for NT-3, TrkC, could be detected in the testis by Northern blot analysis in the 22-day-old to the adult testis. However, only two truncated forms of the receptor were found. Immunocytochemistry revealed that these TrkC isoforms were expressed exclusively in elongated spermatids (Park *et al.*, 2001). Although truncated, these receptor isoforms in the testis appeared to have a functional tyrosine kinase domain, but their affinity for NT-3 might be decreased (Park *et al.*, 2001). Taken together, the expression patterns of

NT-3 and TrkC after birth suggest communication between germ cells at different stages of differentiation, as well as communication between germ cells and Sertoli cells through the p75^{NTR} receptor at the surface of Sertoli cells.

Neurotrophin-4/5 (NT-4/5) and its receptors

Like other neurotrophins, NT-4/5 is expressed in neuronal tissues and also in several peripheral tissues in humans (Ip *et al.*, 1992). It is expressed by many tissues in the rat during embryogenesis (Timmusk *et al.*, 1993a). In most tissues, the expression level of NT-4/5 is much lower than that of the other neurotrophins, and is mainly detectable in the embryo only. However, high levels have been reported in the human prostate (Ip *et al.*, 1992), rat testis (Timmusk *et al.*, 1993a), and *Xenopus* ovary (Hallbook *et al.*, 1991). To exert its effects, NT-4/5 shares the p75^{NTR} and TrkB receptors with other neurotrophins such as BDNF. Zhang and colleagues used a specific and sensitive two-site ELISA assay to detect the expression of NT-4/5 in embryonic and adult tissues (Zhang *et al.*, 1999). They confirmed that NT-4/5 is mainly expressed in the embryo, with the highest amount in the intestine and the lowest amount in the placenta. NT-4/5 expression decreased in all tissues assayed before birth, but increased after birth in the testis, with a peak of expression at 6 days postpartum. The level of NT-4/5 protein then decreased gradually during postnatal development, but still remained detectable in the adult. Thus, it has been suggested that NT-4/5 functions as a growth factor for immature germ cells (Zhang *et al.*, 1999).

Targeted gene disruption and signaling pathways

The roles of neurotrophins and their receptors in development have also been analyzed by targeted gene disruption (Barbacid, 1995). The phenotypes of mice that lack neurotrophins or their specific receptors are similar, indicating that the Trk family of receptors mediates all neurotrophin activities. Since most mutant mice die during the first weeks of life, while the CNS is still developing, the possible consequences of the disrupted genes in the brain cannot be studied by this approach. It also seems that the different neurotrophins compensate for the loss of each other. Moreover, targeted disruption of the neurotrophins and their receptors has not revealed severe

defects outside the nervous system, except for mice lacking NT-3; these mice exhibit a series of cardiac defects that derive from abnormal neural crest cell migration (Donovan *et al.*, 1996). Furthermore, mice lacking NT-3, BDNF, and NT-4/5 show an altered regulation of the hair follicle cycle (Botchkarev *et al.*, 1998; Botchkarev *et al.*, 1999) and skin mast cells (Metz *et al.*, 2004).

Mice lacking the low-affinity receptor $p75^{\text{NTR}}$ show deficiency in the peripheral sensory nervous system, skin abnormalities, growth retardation, and blood vessel abnormalities. They are, however, fertile, and the urogenital tract is normal. Targeted disruptions of TrkA and TrkC are more significant for the reproductive tract and affect mainly embryonic testis development (Cupp *et al.*, 2002). A reduction in the number of testicular cords was observed in both types of knockout mice, and alterations in germ cell numbers were noted as well (Cupp *et al.*, 2002; Robinson *et al.*, 2003). After birth, the disruption of TrkA seemed to dramatically increase cell apoptosis in spermatocytes (Cupp *et al.*, 2002). Thus, TrkA might play a role in spermatocyte maturation or might be a survival factor antagonizing apoptosis in these cells. Nevertheless, the true function of the different neurotrophins and their receptors in postnatal germ cell development has remained largely unresolved, and additional investigations are needed.

Like most signaling molecules, neurotrophins are synthesized as precursor proteins, modified to mature forms, and then secreted. All neurotrophins act as dimers that bind to $p75^{\text{NTR}}$ and Trk transmembrane receptors at the cell surface (Kolbeck *et al.*, 1994). After binding, the receptors dimerize and are activated by autophosphorylation of the catalytic intracellular domain (Bibel *et al.*, 1999). It is worth noting that outside the nervous system, the Trk receptors are mostly truncated isoforms, suggesting that they often act as recruiters for the neurotrophins; while $p75^{\text{NTR}}$ is responsible for the transduction of the signal into the target cell (Sariola, 2001). Receptor activation starts complex intracellular signaling cascades, and many downstream target molecules have been identified (Kaplan and Miller, 1997; Huang and Reichardt, 2003). In particular, Ras, Rap-1, and the Cdc-42-Rac-Rho family — as well as pathways regulated by MAP kinase, PI3-kinase, and phospholipase-C-gamma (PLC-gamma) — have been identified. These pathways are activated after the docking of a set of adaptor proteins (such as Shc, Grb2, Gab1, and FRS2) to phosphorylated tyrosine residues.

The nuclear targets of these pathways have begun to be identified. For example, NGF, through TrkA, inhibits N-myc expression and thus controls the rate of proliferation and differentiation of neurons (Woo *et al.*, 2004). The p75^{NTR} receptor belongs to the tumor necrosis factor receptor family, and was the first identified neurotrophin receptor (Johnson *et al.*, 1986). Although it does not have a catalytic intracellular tyrosine kinase domain, it is capable of mediating the neurotrophin signals. This happens both by modulating Trk receptor signaling and by acting independently of the Trk receptors (Kaplan and Miller, 1997; Nykjaer *et al.*, 2005). Thus, p75^{NTR} can be considered as a coreceptor of Trks or can signal independently. In the latter case, p75^{NTR} activates a distinct set of signaling molecules and pathways within cells, such as NF-kappaB, Akt, and JNK; these pathways can be synergistic or antagonistic to those activated by Trk receptors. In addition, p75^{NTR} is also involved in the apoptosis of neonatal neurons (Roux and Barker, 2002; Nykjaer *et al.*, 2005). The ultimate nuclear targets of neurotrophins and their signaling pathways in testicular somatic and germ cells are still unknown.

Neuroipoietic cytokines

The family of neuroipoietic cytokines includes interleukin-6 (IL-6), interleukin-11 (IL-11), leukemia inhibitory factor (LIF), oncostatin M (OSM), ciliary neurotrophic factor (CNTF), and cardiotrophin-1 (CT-1). Except for CT-1, all neuroipoietic cytokines are expressed in the testis after birth. These cytokines can exert different responses in different tissues (Ernst and Jenkins, 2004). Their activity can also be redundant, since all members of this family use a common signal-transducing component of their receptor complex, the gp130 subunit (Ware *et al.*, 1995; Stewart *et al.*, 1992; Robb *et al.*, 1998; Ernst *et al.*, 2001) (Fig. 2).

Leukemia inhibitory factor (LIF)

Leukemia inhibitory factor (LIF) shows a wide range of biological activities that include the growth and differentiation of different types of target cells such as hematopoietic cells, neuronal cells, primordial germ cells, and type A spermatogonia. LIF also influences bone metabolism, neural development, embryogenesis, and inflammation (Auernhammer and Melmed,

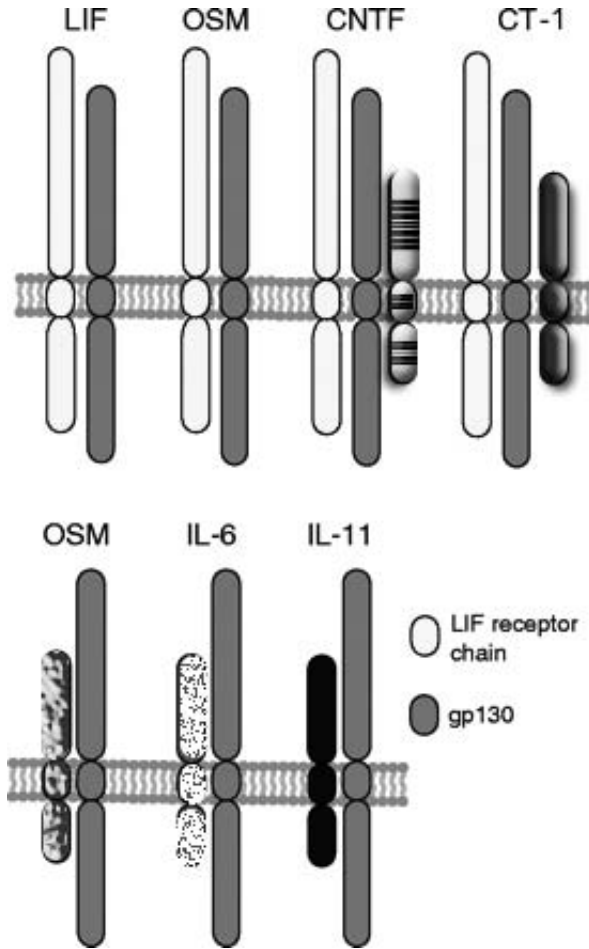

Fig. 2. Neuropoietic cytokines and their receptors. LIF-specific receptor chains are present in the receptor complexes for LIF, OSM, CNTF, and cardiotrophin-1 (CT-1). The gp130 receptor subunit is also present in these receptor complexes, plus those for IL-6 and IL-11. Additional ligand-specific chains are present in the receptors for CNTF, CT-1, IL-6, IL-11, and an alternate OSM receptor. From Metcalf (2003).

2000). LIF is also one of the cytokines capable of maintaining the self-renewal of embryonic stem cells (Williams *et al.*, 1988; Smith *et al.*, 1988). LIF has been shown to promote the proliferation of murine primordial germ cells (PGCs) (Matsui *et al.*, 1991; Cheng *et al.*, 1994) and their survival by preventing their apoptosis (Pesce *et al.*, 1993). LIF alone has been used

to maintain the survival and growth of gonocytes in cocultures with Sertoli cells (De Miguel *et al.*, 1996). Furthermore, Nikolova and colleagues observed that LIF increased the mitotic activity of gonocytes in organ cultures (Nikolova *et al.*, 1997). In combination with other growth factors, LIF is essential for the long-term culture of PGCs and gonocytes, and induces their reprogramming to pluripotential embryonic stem cells (Matsui *et al.*, 1992; Resnick *et al.*, 1992; Stewart *et al.*, 1994; Cheng *et al.*, 1994; Kanatsu-Shinohara *et al.*, 2003; Kanatsu-Shinohara *et al.*, 2004).

The expression of LIF in the prenatal and postnatal testis has been investigated, revealing that Sertoli and peritubular cells are the main testicular cells that produce LIF (De Miguel *et al.*, 1996; Piquet-Pellorce *et al.*, 2000). In addition, hCG was found to stimulate Leydig cell LIF production (Piquet-Pellorce *et al.*, 2000). The LIF-specific receptor subunit (LIFR α /gp190) is expressed by spermatogonia and, to a lesser extent, by all types of somatic cells. This strongly suggests that spermatogonia are the major targets of LIF in the postnatal testis. Interestingly, meiotic and postmeiotic germ cells express a truncated form of the LIF receptor, which is devoid of its extracellular functional binding sites (Dorval-Coiffec *et al.*, 2005). Moreover, LIF is able to stimulate spermatogonial proliferation in adult rat organ cultures of seminiferous tubules (Dorval-Coiffec *et al.*, 2005). Taken together, these observations strongly suggest that LIF is involved in postnatal germ cell development, probably by stimulating growth or by counteracting apoptosis in gonocytes and proliferating spermatogonia.

Ciliary neurotrophic factor (CNTF)

CNTF was originally described as a factor that supported the *in vitro* survival of parasympathetic neurons from ciliary ganglia (Helfand *et al.*, 1976; Adler *et al.*, 1979; Stockli *et al.*, 1989). Its trophic and differentiating effects on different types of peripheral and central neurons and on glial populations was soon demonstrated as well (Hughes *et al.*, 1988; Saadat *et al.*, 1989; Sendtner *et al.*, 1992). More recently, Baumann and colleagues established the role of CNTF on cell function outside the nervous system (Baumann *et al.*, 1993). CNTF also maintains the pluripotentiality of mouse embryonic stem cells (Conover *et al.*, 1993). De Miguel and colleagues have investigated the expression and role of CNTF in the postnatal testis

(De Miguel *et al.*, 1996). They determined that, like LIF, CNTF promotes the survival of gonocytes and Sertoli cells in culture; in addition, CNTF stimulates the proliferation of quiescent gonocytes. It was speculated that the function of LIF at the start of spermatogenesis might be duplicated by CNTF, ensuring the maintenance of normal reproductive activity. Targeted disruption of LIF did not promote sterility; this might be due to the trophic effect of CNTF on gonocytes in these animals.

Oncostatin M (OSM)

Oncostatin M (OSM) was originally purified as a protein that could inhibit the proliferation of cells derived from a human melanoma (Zarling *et al.*, 1986), and was later identified as an autocrine growth factor for Kaposi's sarcoma (Miles *et al.*, 1992). Examination of the human OSM protein sequence suggests that OSM shares a close relationship with leukemia inhibitory factor (LIF) (Rose and Bruce, 1991), and that both genes evolved from a common ancestral gene (Jeffery *et al.*, 1993; Rose *et al.*, 1993). Mouse OSM has been cloned, and the expression of its specific receptor subunit has been investigated (Hara *et al.*, 1997). The OSM receptor is expressed in many organs throughout embryonic development and after birth, and is detectable in the adult central and peripheral nervous systems as well as in many organs such as the lymph node, bone, heart, kidney, small intestine, nasal cavity, and lung (Tamura *et al.*, 2003; Tamura *et al.*, 2002). Oncostatin M acts on many different types of cells, including hepatocytes, dermal fibroblasts, and hematopoietic cells (Nakamura *et al.*, 2004; Ihn and Tamaki, 2000; Tanaka *et al.*, 2003). In addition, OSM enhances the survival of postmigratory PGCs (Hara *et al.*, 1998).

De Miguel and colleagues identified two forms of OSM in the rat testis: one form of OSM was highly expressed in the late fetal and early neonatal rat testis, and exhibited a molecular weight of 36 000 Da; the other form of OSM was expressed in the maturing and adult testis, and had a molecular weight of 22 000 Da (de Miguel *et al.*, 1997). The expression of OSM was found in interstitial Leydig cells at all stages studied; while the expression by Sertoli cells was strongest at 3 dpp, around the start of spermatogenesis. Cocultures of Sertoli cells and gonocytes isolated from newborn rats

revealed that OSM significantly increased the survival of both Sertoli cells and gonocytes in a dose-dependent manner (de Miguel *et al.*, 1997). Sertoli cell proliferation was not affected by OSM; however, the proliferative activity of the gonocytes was increased by almost 60% after 6 days of culture, and this effect of OSM seems to be more potent than LIF or CNTF (de Miguel *et al.*, 1997). Therefore, OSM is likely to play an important role at the start of spermatogenesis. For this reason, OSM, along with other growth factors, has been used to maintain murine testicular germ cells in long-term cultures (Jeong *et al.*, 2003).

Interleukin-6 (IL-6) and interleukin-11 (IL-11)

Like the other members of the neuropoietic cytokine family, interleukin-6 and interleukin-11 are multifunctional growth, survival, and differentiation factors that act on neurons and other cell types. IL-6 was originally identified as a B-cell differentiation factor that induced the final maturation of B cells into antibody-producing cells (Hirano *et al.*, 1986). Subsequent studies have shown that IL-6 acts not only on B cells, but also on T cells, hepatocytes, hematopoietic progenitor cells, and neuronal cells (Chiu *et al.*, 1988; Habetswallner *et al.*, 1988; Castell *et al.*, 1988; Hudak *et al.*, 1992; Munoz-Fernandez and Fresno, 1998). In the rat and human testes, IL-6 is produced essentially by Leydig and Sertoli cells *in vivo* and *in vitro*, and IL-6 production by Sertoli cells in culture seems to be dependent on FSH (Hakovirta *et al.*, 1995; Cudicini *et al.*, 1997a; Cudicini *et al.*, 1997b).

The IL-6 receptor is expressed by Leydig cells and germ cells. Human recombinant IL-6 inhibits the onset of meiotic DNA synthesis of rat preleptotene spermatocytes in a dose-dependent manner, and a minor inhibition has been found on differentiating spermatogonia as well (A₃ to type B spermatogonia) (Hakovirta *et al.*, 1995). The regulation of IL-6 production by Sertoli cells seems to be complex, and is dependent on the combined action of hormones, cytokines, and growth factors (Stephan *et al.*, 1997). More recently, Potashnik and colleagues examined the cellular origin and the expression levels of IL-6 during normal maturation of mouse testis (Potashnik *et al.*, 2005). In general, expression levels of IL-6 were higher in testicular homogenates of sexually immature than mature mice. The cellular

origin of IL-6 was revealed by immunohistochemistry, which indicated that not only somatic cells, but also germ cells at different stages of differentiation express IL-6.

Interleukin-11 (IL-11) was initially identified as a soluble factor produced by bone marrow stromal cells in the primate (Paul *et al.*, 1990). IL-11 induces neuronal differentiation and, either alone or in synergy with other cytokines, is capable of stimulating the production of several hematopoietic lineages *in vitro* (Turner and Clark, 1995). Other activities of IL-11 include inhibition of adipogenesis (Kawashima *et al.*, 1991; Keller *et al.*, 1993) and regulation of cartilage and bone function (Maier *et al.*, 1993; Girasole *et al.*, 1994). IL-11 is highly expressed in the testis in comparison with other tissues, and its specific receptor IL-11R α is expressed by Sertoli and Leydig cell lines (Davidson *et al.*, 1997). Du and colleagues found that IL-11 is developmentally regulated in the testis, and is exclusively produced by spermatogonia and round spermatids at stages VI–IX of the seminiferous tubules (Du *et al.*, 1996). However, administration of IL-11 *in vivo* accelerates the recovery of spermatogenesis after cytotoxic therapy, implying an autocrine pathway (Du *et al.*, 1996).

Signal transduction by neuropoietic cytokines and gene targeting

All neuropoietic cytokines bind to a heterodimeric receptor that consists of a neuropoietic cytokine-specific binding subunit and the transmembrane signal transducing subunit gp130 (Fig. 2) (Heinrich *et al.*, 1998). Cytokines such as LIF, CNTF, and OSM use both the LIF receptor (gp190) and gp130 to transduce their signals, and are called LIF-related cytokines. Binding of the neuropoietic cytokines to the LIF-, OSM-, IL-6-, or IL-11-specific receptors recruits gp130, and results in the activation of a signal transduction cascade. The activated receptor complexes are all able to activate Janus kinases, which phosphorylate the cytoplasmic part of gp130, thereby creating docking sites for the STAT factors STAT1 and STAT3. STATs become phosphorylated and form homodimers or heterodimers that translocate into the nucleus, where they regulate gene transcription. STAT proteins are ubiquitously expressed, except for STAT4, which is expressed only in myeloid cells and postmeiotic germ cells (Herrada and Wolgemuth, 1997). A variety of target genes are regulated by IL-6-type cytokines via STATs; they

include many enzymes, and transcription factors such as JunB, c-Fos, and c-Myc (Heinrich *et al.*, 1998; Kiuchi *et al.*, 1999). STAT-binding sites are often in close proximity to binding sites for other transcription factors, suggesting cooperation between these factors in gene regulation. Furthermore, the Ras/mitogen-activated protein kinase (MAPK) and PI3K signaling pathways can be activated by gp130, and cross-talks between these pathways are likely to enhance, prolong, or specify the signals (Hirano *et al.*, 1997).

Because the gp130 subunit is shared by all neuropoietic cytokines, mice lacking gp130 die by midgestation, indicating that this receptor is essential for development and many physiological processes (Yoshida *et al.*, 1996). Similarly, mice lacking the LIF-Ra/gp190 subunit die shortly after birth (Ware *et al.*, 1995). The phenotypes of mice with a null mutation for neuropoietic cytokines are milder, and the most striking defects are observed in LIF-deficient mice. These mutants have reduced numbers of stem cells in the spleen and bone marrow, enhanced inflammatory responses, impaired sensory neuron regeneration, and uterine abnormalities (Dani *et al.*, 1998). Indeed, LIF-deficient female mice fail to implant blastocysts (Stewart *et al.*, 1992). *In vivo* studies of mice overexpressing LIF suggest that LIF is involved in the control of male reproduction, since spermatogenesis is disturbed. However, male mice whose gp130 was inactivated specifically in germ cells using a Cre-LoxP system were still fertile, suggesting that the influence of LIF after birth is compensated by other neuropoietic cytokines (Dorval-Coiffec *et al.*, 2005).

GDNF family of neurotrophic factors

Glial cell line-derived neurotrophic factor (GDNF) is a potent neurotrophic molecule that was identified in conditioned media of glioma cell line cultures (Lin *et al.*, 1993). GDNF is able to promote the survival of dopaminergic neurons and other neuronal populations *in vivo* and *in vitro* (Lin *et al.*, 1993; Buj-Bello *et al.*, 1995; Henderson *et al.*, 1994). It is also known to induce the differentiation of several types of peripheral neurons (Zurn *et al.*, 1996). The expression of GDNF is not limited to the nervous system: it is also found in the skin, whisker pad, kidney, stomach, skeletal muscle, and testis (Trupp *et al.*, 1995; Golden *et al.*, 1999). GDNF is also important for the development of the embryonic kidney (Schuchardt *et al.*, 1994; Moore *et al.*, 1996) and the developing gastrointestinal tract (Hellmich *et al.*, 1996),

and is now recognized as an essential molecule for determining the fate of spermatogonial stem cells (Meng *et al.*, 2000; Naughton *et al.*, 2006; Hofmann *et al.*, 2005b; Braydich-Stolle *et al.*, 2005).

Cloning of GDNF revealed that it is a distant member of the transforming growth factor beta (TGF- β) superfamily (Lin *et al.*, 1993). The GDNF family contains four neurotrophic factors: glial cell line-derived neurotrophic factor (GDNF), neurturin (NTN), artemin (ATM), and persephin (PSP) (reviewed by Airaksinen and Saarma, 2002). GDNF family members dimerize and function via a multicomponent receptor complex (Fig. 3), which includes a glycosyl-phosphatidylinositol (GPI)-linked cell surface coreceptor and a signal-transducing receptor, the Ret receptor (Jing *et al.*, 1996; Treanor *et al.*, 1996). GDNF, neurturin, artemin, and persephin bind with high affinity to specific coreceptors belonging to the GDNF family of receptors (GFR) called GFR α -1, GFR α -2, GFR α -3, and GFR α -4, respectively (Airaksinen and Saarma, 2002). However, weak cross-binding of each ligand to other coreceptors is possible. In the testis, GDNF and neurturin are produced by the Sertoli cells (Viglietto *et al.*, 2000; Meng *et al.*, 2000; Meng *et al.*, 2001b), and this activity extends throughout life (Chen *et al.*, 2005).

GDNF-knockout mice and transgenic studies

Mice lacking GDNF die within the first day of birth with renal and neuronal abnormalities, including absent ureteric bud, kidney, and enteric neurons (Moore *et al.*, 1996; Pichel *et al.*, 1996; Sanchez *et al.*, 1996). The heterozygote animals also display kidney development defects and lack an enteric nervous system. The Ret and GFR α -1 receptors have also been knocked out (Schuchardt *et al.*, 1994; Enomoto *et al.*, 1998; Cacalano *et al.*, 1998; Tomac *et al.*, 2000). These latter mice die during the first postnatal day and exhibit the same phenotypes as the GDNF-knockout animals, indicating that GDNF signals through the GFR α 1/Ret-receptor complex and is essential for postnatal survival in the mouse.

In general, the testicular morphology of mice lacking GDNF, GFR α -1, and Ret is normal before birth. While GDNF^{+/-} mice survive to adulthood and are fertile, histological analysis of their testes has shown that spermatogenesis is disturbed (Meng *et al.*, 2000). In particular, some seminiferous tubules are degenerated and contain spermatids in an abnormal

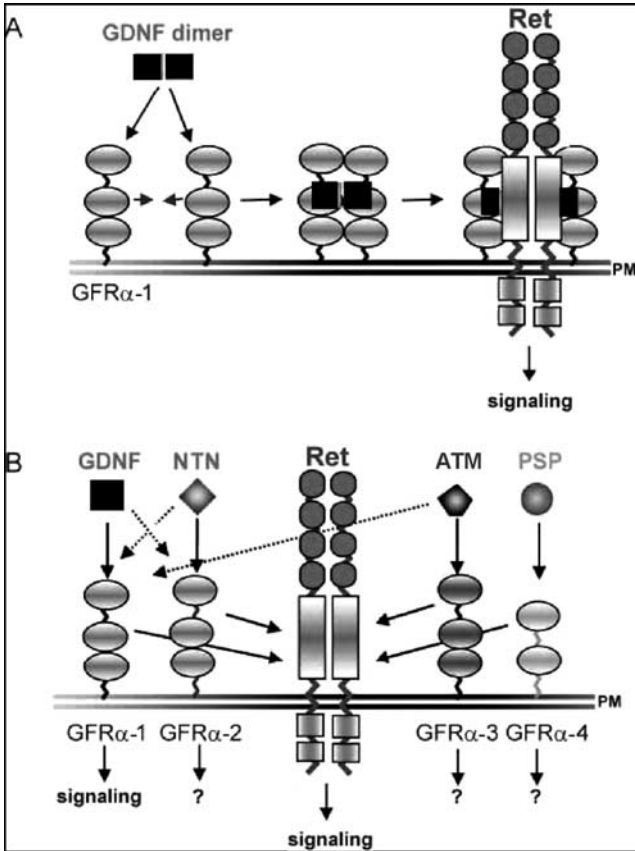

Fig. 3. GDNF family proteins and their receptors. A. GDNF dimer binding to GFR α -1 receptors and associating with Ret. B. GDNF family ligands and their preferential GFR α receptors. From Sariola and Saarma (2003).

position or phagocytosed by Sertoli cells. In older GDNF^{+/-} mice, depletion of the germ cells often results in Sertoli cell-only seminiferous tubules without spermatogonia, while in other tubules the rate of spermatogonial proliferation is reduced. Thus, GDNF is an essential factor for the development of undifferentiated spermatogonia, including the stem cells. Recently, Naughton and colleagues circumvented the neonatal mortality of ^{-/-} mice by transplanting GDNF-, GFR α -1-, and Ret-deficient neonatal testes under the back skin of immunodeficient mice (Naughton *et al.*, 2006). This strategy revealed that any disruption of GDNF-mediated

Ret signaling results in a lack of spermatogonial stem cell self-renewal, and induces the progressive loss of spermatogenesis by germ cell depletion.

Several mouse transgenic lines have been constructed that show overexpression of GDNF in specific tissues by driving its expression with tissue-specific promoters (Nguyen *et al.*, 1998; Zwick *et al.*, 2003). In 2000, Meng and colleagues overexpressed GDNF in transgenic mice under the testis-specific human translation elongation factor-1a (EF-1a) promoter (Abdallah *et al.*, 1991; Meng *et al.*, 2000). The mice overexpressing GDNF accumulated undifferentiated spermatogonia. Thus, GDNF contributes to the paracrine regulation of spermatogonial stem cell self-renewal and the first steps of their differentiation. GDNF-overexpressing mice are infertile and develop testicular tumors resembling seminoma in adulthood (Meng *et al.*, 2001a). However, the usefulness of these mice to study the etiology of these tumors in men is controversial, since the precursor lesion seems different in both species (Sariola and Meng, 2003). Neurturin has also been overexpressed in the testis (Meng *et al.*, 2001b). These mice are fertile and show only segmental defects in spermatogenesis. The primary coreceptor for neurturin, GFR α -2, is expressed in spermatocytes and spermatids, and the overexpression of neurturin induces only a transient disruption of spermatocyte production during week 3 and week 5 after birth.

Ret receptor tyrosine kinase and signal transduction

The functional receptor for GDNF is the Ret tyrosine kinase (rearranged during transfection) originally discovered by Takahashi and colleagues, who showed a novel gene rearrangement and oncogenic activation in a transfection assay of NIH 3T3 cells with lymphoma DNA (Takahashi *et al.*, 1985). The activated gene was then found to code for a novel tyrosine kinase that has an extracellular ligand-binding domain with two cadherin-like repeats: a hydrophobic transmembrane region and a cytoplasmic domain with an intrinsic tyrosine kinase activity. The Ret gene has 21 exons that span more than 60 kb of genomic DNA, and the mRNA can be alternatively spliced to produce up to 10 protein isoforms (Myers *et al.*, 1995).

Like other tyrosine kinases, upon ligand binding Ret autophosphorylates its tyrosine domains. There exist, so far, two models for Ret

activation in neurons (Arighi *et al.*, 2005). In the *cis* model, GDNF dimers bind to GFRalpha-1 receptors, which are located in lipid rafts. The GDNF/GFRalpha-1 complex binds and recruits Ret to the lipid rafts, promoting its dimerization and autophosphorylation. In the *trans* model, GDNF binds to a soluble form of GFRalpha-1. The GDNF/GFRalpha-1 complex binds to Ret, which dimerizes and autophosphorylates and then is finally recruited to the rafts. Within the rafts, Ret associates with FRS2 (FGF receptor substrate 2); while outside the rafts, Ret associates with the adaptor Shc.

Many tyrosine residues can be phosphorylated in the intracellular domain of Ret, and thus can serve as docking sites to many different SH2 domain-containing proteins. For example, phosphorylated Tyr 1062 serves as a docking site to many effectors, including Shc, which leads to the activation of at least two major pathways: the Ras-MAP kinase pathway (Worby *et al.*, 1996) and the PI3K/Akt pathway (Segouffin-Cariou and Billaud, 2000) (Fig. 4). The signal via Tyr 1062 plays an important role in the histogenesis of the enteric nervous system and in nephrogenesis. GDNF has also

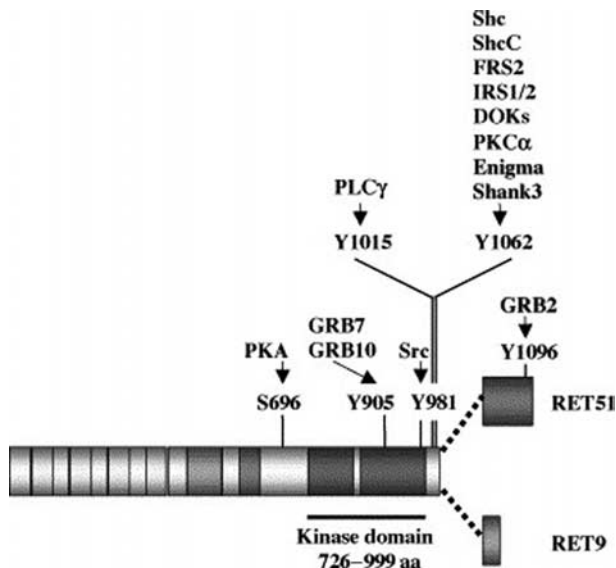

Fig. 4. Intracellular signal transducers of activated Ret. Phosphorylated Tyr 1062 serves as a docking site to many downstream effectors. Phosphorylated Tyr 981 recruits Src, which is activated in spermatogonial stem cells. From Arighi *et al.* (2005).

been shown to signal through a Ret-independent signaling pathway in cells that do not express Ret, mainly involving Src kinases and other receptors such as Met and NCAM (Popsueva *et al.*, 2003; Paratcha *et al.*, 2003). We recently elucidated some of the pathways induced by GDNF in spermatogonial stem cells. Spermatogonial stem cells express GFR α -1 and Ret, and several kinases from the Src family coprecipitate with Ret after GDNF stimulation (Braydich-Stolle *et al.*, in revision).

Interestingly, while in most tissues GDNF signals through Ret phosphorylation at Tyr 1062 and through activation of a Ras-dependent pathway (Lee *et al.*, 2006), in spermatogonial stem cells Src kinases seem to be the effector molecules binding to Ret, probably at Tyr 981. Four Src family kinases have so far been implicated in spermatogonial stem cell proliferation through Ret activation: Src, Yes, Lyn, and Fyn, which are all inhibited by the pharmacological inhibitor SU6656. Although the functions of these kinases overlap, it is believed that Src and Yes play a predominant role in the immediate response of primary SSCs to GDNF. When the cells are differentiating into A_{paired} and A_{aligned} spermatogonia, all four kinases seem involved. Interestingly, the immortalized cell line C18-4, which presents some characteristics of SSCs, expresses only the Fyn kinase (Hofmann *et al.*, 2005a). Therefore, it might be possible that this cell line represents a more advanced stage in spermatogenesis, such as A_{paired} spermatogonia. In response to GDNF, the Src family kinases activate the PI3K/Akt pathway, which ultimately leads to N-Myc expression and the promotion of SSC proliferation *in vitro*. Thus, we identified, for the first time, a nuclear target of GDNF/Ret signaling in spermatogonial stem cells (Fig. 5).

Cooperation of GDNF with other growth factors and signaling pathways

The effect of GDNF on nerve cells requires the presence of transforming growth factor beta (TGF- β) *in vitro* and *in vivo* (Peterziel *et al.*, 2002). This cooperative effect is mediated by the MAPK/ERK pathway. In the absence of TGF- β , GDNF has no functional influence on neurons. However, pretreatment with TGF- β confers GDNF responsiveness to the cells, and it is believed that TGF- β recruits the GFR α -1 receptor to the plasma membrane for binding to GDNF. A true cooperation of TGF- β and GDNF that mediates

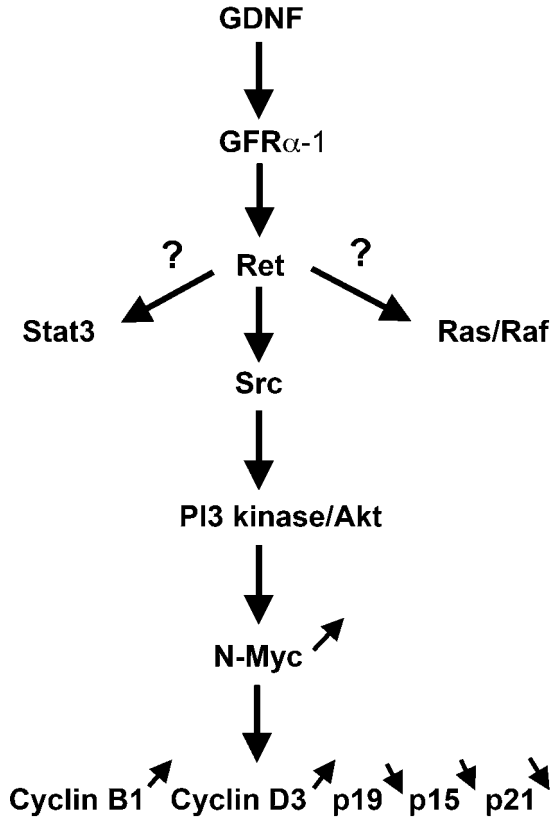

Fig. 5. Signaling pathway triggered by GDNF in spermatogonial stem cells. Activated Ret recruits Src family kinases, which in turn are phosphorylated and activate a PI3K/Akt pathway. Eventually, N-Myc production is increased, which stimulates cyclins and cell proliferation.

the effects of GDNF on spermatogonial stem cell proliferation has not yet been demonstrated.

GDNF is also able to promote the branching of kidney cells (MDCK cells) in the absence of Ret by inducing Src activation and the phosphorylation of Met, the receptor for HGF (Popsueva *et al.*, 2003). Since the Met receptor is expressed in germ cells, it is possible that GDNF exerts some of its effects on spermatogonia through the indirect activation of Met (Catizone *et al.*, 2006), thus bypassing Ret signaling. Furthermore, Ret-independent signaling can also be mediated by NCAM. In this case, NCAM acts as an

alternative receptor, and the binding of GDNF to NCAM activates Fyn, a member of the Src kinase family (Paratcha *et al.*, 2003).

In order to establish which genes are differentially regulated by GDNF, we recently performed microarray analysis of spermatogonial stem cells under the influence of GDNF *in vitro* (Hofmann *et al.*, 2005b). We identified components of two additional signaling pathways that are modulated by GDNF. By upregulating the expression of the protein Numb, an antagonist of the Notch receptor, GDNF interacts with the Notch signaling pathway. The Notch signaling pathway is important for stem cell self-renewal and lineage determination in many mammalian tissues, and might play a role in germ line stem cell development. Expression of the Notch receptors (Notch-1 to Notch-3) has been detected in mouse and rat spermatogonial stem cells, while the ligands Jagged-1 and Jagged-2 are expressed by Sertoli cells (Dirami *et al.*, 2001; Hayashi *et al.*, 2001). Deficiency of Notch signaling induces infertility in men by blocking spermatogenesis before meiosis (Hayashi *et al.*, 2004). Thus, in the mammalian germ line, Notch activation might induce cell differentiation rather than self-renewal. Notch is a transmembrane receptor activated by juxtacrine signaling (Weinmaster, 1997). Upon the binding of their ligands Jagged-1 and Jagged-2, the Notch receptors are cleaved and release their intracellular domain (NICD), which translocates to the nucleus and functions as a transcription factor (Fig. 6A).

In our hands, GDNF does not directly induce the differential expression of the *notch* genes; however, it induces the upregulation of the gene *numb*, which is a direct antagonist of NICD and promotes its posttranslational degradation by ubiquitination (McGill and McGlade, 2003). Furthermore, immunocytochemistry data revealed that after overnight treatment with GDNF *in vitro*, many A_{single} spermatogonia expressed Numb (73%), while the staining was not observed in the absence of GDNF (Braydich-Stolle *et al.*, 2005). GDNF also specifically upregulated the testis isoform of Numb (MW = 72 kDa) in spermatogonial stem cells, and a concomitant decrease in NICD protein expression was observed (Braydich-Stolle *et al.*, 2005) (Fig. 6B). Taken together, GDNF is able to downregulate the Notch signaling pathway by upregulating Numb, and might thus influence the decision of a germ line stem cell to self-renew rather than differentiate.

We also found that GDNF was able to upregulate the expression of fibroblast growth factor receptor 2 (FGFR2), suggesting that GDNF might render germ line stem cells responsive to bFGF and that a cooperation

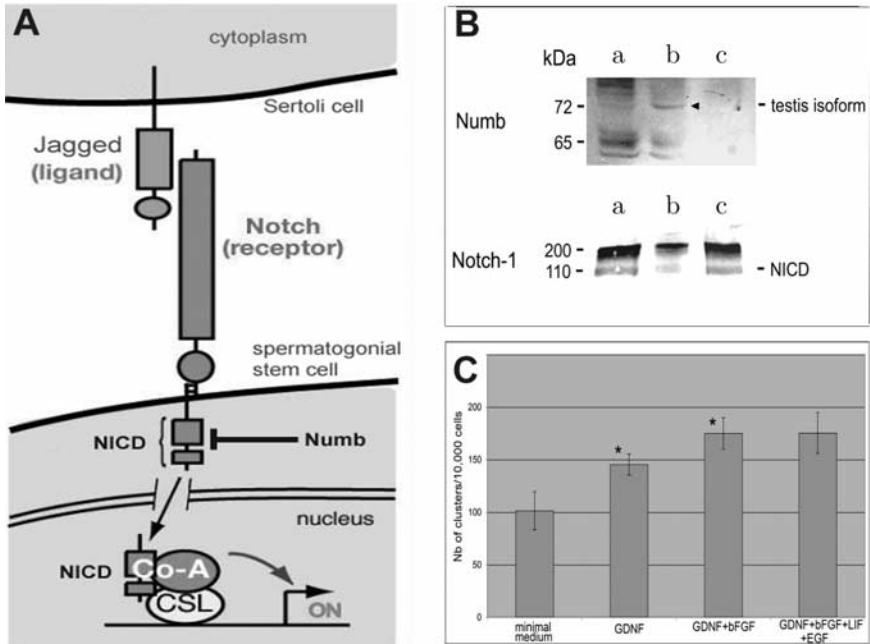

Fig. 6. Modulation of signaling pathways by GDNF. **A.** The Notch signaling pathway. After binding to Jagged, the intracellular portion of the Notch receptor is cleaved, becoming NICD (Notch intracellular domain). NICD is a transcription factor that eventually translocates into the nucleus. Numb is known as an antagonist of NICD, promoting its ubiquitination. Through the upregulation of *numb*, GDNF might influence the fate of spermatogonial stem cells. Adapted from E. Lai, Memorial Sloan-Kettering Cancer Center, Sloan-Kettering Institute, New York, NY. **B.** Expression of Numb and Notch-1 in seminiferous tubules treated with GDNF. Seminiferous tubules were cultured for 3 days in the presence of 100 ng/mL GDNF and prepared for SDS-PAGE/Western blotting. **(a)** No GDNF; **(b)** GDNF; **(c)** GDNF + 5 μ g/mL neutralizing antibody. *Upper panel:* Western blot for Numb, showing upregulation of the testis isoform of Numb by GDNF (arrowhead). *Lower panel:* Western blot for Notch-1, showing downregulation of NICD by GDNF. From Braydich-Stolle *et al.* (2005). **C.** Growth of spermatogonial stem cell clusters in the presence of GDNF and bFGF after 5 days of culture. GFR α -1 positive spermatogonia were isolated with the Staptut/magnetic bead method and cultured for 5 days with or without GDNF (100 ng/mL) and bFGF (10 ng/mL) in controlled conditions. bFGF amplified the effect of GDNF on cluster numbers, but not cluster size. Addition of other growth factors such as LIF and EGF did not further increase the number of clusters produced. From Hofmann *et al.* (2005b).

of both growth factors is essential for their proliferation (Hofmann *et al.*, 2005b) (Fig. 6C). bFGF amplified the effects of GDNF, while the addition of other growth factors did not further stimulate proliferation, indicating that the combination GDNF/FGF is the limiting factor. FGFR2 is also expressed

by human spermatogonial stem cells, and may play a role analogous to Ret in regulating their clonal expansion and fate (Goriely *et al.*, 2003). GDNF and bFGF are part of a cocktail of factors used recently by several investigators to establish long-term cultures of gonocytes and spermatogonial stem cells (Kanatsu-Shinohara *et al.*, 2003; Kubota *et al.*, 2004). Thus, these findings confirm that the cooperation between GDNF and bFGF is likely essential to maintain spermatogonial stem cell self-renewal or proliferation/differentiation.

Summary and Conclusions

Neurotrophic factors are soluble molecules known mainly for maintaining and regulating the development of neuronal cells. However, gene-targeting approaches over the past decade revealed that these factors possess distinct functions outside the nervous system. In particular, these molecules seem to play an important role in the maintenance, proliferation, and differentiation of the male germ line after birth. Indeed, the expression of these factors and their receptors is spatially and temporally regulated during spermatogenesis. Some of the signaling pathways induced by neurotrophic factors are now unraveled, which improves our understanding of the molecular events regulating spermatogenesis.

Of special interest is glial cell line-derived neurotrophic factor (GDNF), since it regulates the fate of spermatogonial stem cells. GDNF signals through a multicomponent membrane receptor that includes the Ret transmembrane receptor. While some interactions of Ret with intracellular downstream targets have been identified, the target genes or transcription factors that are ultimately modulated in response to Ret activation are not well known. We identified Src kinases as mediators of Ret activation in spermatogonial stem cells, and *N-myc* as a target gene that is responsible for their proliferation *in vitro*. However, it has become clear that neurotrophic factors such as GDNF cooperate with other paracrine and juxtacrine factors and can indirectly modulate other signaling pathways, providing a molecular network that ultimately regulates the first steps of spermatogenesis. In the future, the precise identification of these molecules and pathways will provide new tools for the treatment of male infertility and help to discover the etiology of certain testicular cancers.

Acknowledgments

Our work was supported by NIH grants RO1-HD36483 and RO1-HD044543, and a grant from the Lance Armstrong Foundation.

References

- Abdallah, B., Hourdry, J., Krieg, P. A., Denis, H., and Mazabraud, A. (1991). Germ cell-specific expression of a gene encoding eukaryotic translation elongation factor 1 alpha (eEF-1 alpha) and generation of eEF-1 alpha retroseudogenes in *Xenopus laevis*. *Proc Natl Acad Sci U S A* **88**, 9277–9281.
- Adler, R., Landa, K. B., Manthorpe, M., and Varon, S. (1979). Cholinergic neuronotrophic factors: intraocular distribution of trophic activity for ciliary neurons. *Science* **204**, 1434–1436.
- Airaksinen, M. S., and Saarma, M. (2002). The GDNF family: signalling, biological functions and therapeutic value. *Nat Rev Neurosci* **3**, 383–394.
- Arighi, E., Borrello, M. G., and Sariola, H. (2005). RET tyrosine kinase signaling in development and cancer. *Cytokine Growth Factor Rev* **16**, 441–467.
- Auernhammer, C. J., and Melmed, S. (2000). Leukemia-inhibitory factor — neuroimmune modulator of endocrine function. *Endocr Rev* **21**, 313–345.
- Ayer-LeLievre, C., Olson, L., Ebendal, T., Hallbook, F., and Persson, H. (1988). Nerve growth factor mRNA and protein in the testis and epididymis of mouse and rat. *Proc Natl Acad Sci U S A* **85**, 2628–2632.
- Barbacid, M. (1995). Neurotrophic factors and their receptors. *Curr Opin Cell Biol* **7**, 148–155.
- Barde, Y. A., Edgar, D., and Thoenen, H. (1982). Purification of a new neurotrophic factor from mammalian brain. *EMBO J* **1**, 549–553.
- Baumann, H., Ziegler, S. F., Mosley, B., Morella, K. K., Pajovic, S., and Gearing, D. P. (1993). Reconstitution of the response to leukemia inhibitory factor, oncostatin M, and ciliary neurotrophic factor in hepatoma cells. *J Biol Chem* **268**, 8414–8417.
- Berkemeier, L. R., Winslow, J. W., Kaplan, D. R., Nikolics, K., Goeddel, D. V., and Rosenthal, A. (1991). Neurotrophin-5: a novel neurotrophic factor that activates trk and trkB. *Neuron* **7**, 857–866.
- Bibel, M., Hoppe, E., and Barde, Y. A. (1999). Biochemical and functional interactions between the neurotrophin receptors trk and p75^{NTR}. *EMBO J* **18**, 616–622.
- Botchkarev, V. A., Botchkareva, N. V., Welker, P., Metz, M., Lewin, G. R., Subramaniam, A., Bulfone-Paus, S., Hagen, E., Braun, A., Lommatzsch, M., Renz, H., and Paus, A. R. (1999). A new role for neurotrophins: involvement of brain-derived neurotrophic factor and neurotrophin-4 in hair cycle control. *FASEB J* **13**, 395–410.
- Botchkarev, V. A., Welker, P., Albers, K. M., Botchkareva, N. V., Metz, M., Lewin, G. R., Bulfone-Paus, S., Peters, E. M., Lindner, G., and Paus, R. (1998). A new role for neurotrophin-3: involvement in the regulation of hair follicle regression (catagen). *Am J Pathol* **153**, 785–799.

- Braydich-Stolle, L., Nolan, C., Dym, M., and Hofmann, M. C. (2005). Role of glial cell line-derived neurotrophic factor in germ-line stem cell fate. *Ann N Y Acad Sci* **1061**, 94–99.
- Buj-Bello, A., Buchman, V. L., Horton, A., Rosenthal, A., and Davies, A. M. (1995). GDNF is an age-specific survival factor for sensory and autonomic neurons. *Neuron* **15**, 821–828.
- Cacalano, G., Farinas, I., Wang, L. C., Hagler, K., Forgie, A., Moore, M., Armanini, M., Phillips, H., Ryan, A. M., Reichardt, L. F., Hynes, M., Davies, A., and Rosenthal, A. (1998). GFRalpha1 is an essential receptor component for GDNF in the developing nervous system and kidney. *Neuron* **21**, 53–62.
- Castell, J. V., Gomez-Lechon, M. J., David, M., Hirano, T., Kishimoto, T., and Heinrich, P. C. (1988). Recombinant human interleukin-6 (IL-6/BSF-2/HSF) regulates the synthesis of acute phase proteins in human hepatocytes. *FEBS Lett* **232**, 347–350.
- Catizone, A., Ricci, G., Del Bravo, J., and Galdieri, M. (2006). Hepatocyte growth factor modulates *in vitro* survival and proliferation of germ cells during postnatal testis development. *J Endocrinol* **189**, 137–146.
- Chao, M. V., Bothwell, M. A., Ross, A. H., Koprowski, H., Lanahan, A. A., Buck, C. R., and Sehgal, A. (1986). Gene transfer and molecular cloning of the human NGF receptor. *Science* **232**, 518–521.
- Chen, C., Ouyang, W., Grigura, V., Zhou, Q., Carnes, K., Lim, H., Zhao, G. Q., Arber, S., Kurpios, N., Murphy, T. L., Cheng, A. M., Hassell, J. A., Chandrashekar, V., Hofmann, M. C., Hess, R. A., and Murphy, K. M. (2005). ERM is required for transcriptional control of the spermatogonial stem cell niche. *Nature* **436**, 1030–1034.
- Chen, Y., Dicou, E., and Djakiew, D. (1997). Characterization of nerve growth factor precursor protein expression in rat round spermatids and the trophic effects of nerve growth factor in the maintenance of Sertoli cell viability. *Mol Cell Endocrinol* **127**, 129–136.
- Cheng, L., Gearing, D. P., White, L. S., Compton, D. L., Schooley, K., and Donovan, P. J. (1994). Role of leukemia inhibitory factor and its receptor in mouse primordial germ cell growth. *Development* **120**, 3145–3153.
- Chiu, C. P., Moulds, C., Coffman, R. L., Rennick, D., and Lee, F. (1988). Multiple biological activities are expressed by a mouse interleukin 6 cDNA clone isolated from bone marrow stromal cells. *Proc Natl Acad Sci U S A* **85**, 7099–7103.
- Conover, J. C., Ip, N. Y., Poueymirou, W. T., Bates, B., Goldfarb, M. P., DeChiara, T. M., and Yancopoulos, G. D. (1993). Ciliary neurotrophic factor maintains the pluripotentiality of embryonic stem cells. *Development* **119**, 559–565.
- Cudicini, C., Kercret, H., Touzalin, A. M., Ballet, F., and Jegou, B. (1997a). Vectorial production of interleukin 1 and interleukin 6 by rat Sertoli cells cultured in a dual culture compartment system. *Endocrinology* **138**, 2863–2870.
- Cudicini, C., Lejeune, H., Gomez, E., Bosmans, E., Ballet, F., Saez, J., and Jegou, B. (1997b). Human Leydig cells and Sertoli cells are producers of interleukins-1 and -6. *J Clin Endocrinol Metab* **82**, 1426–1433.
- Cupp, A. S., Kim, G. H., and Skinner, M. K. (2000). Expression and action of neurotrophin-3 and nerve growth factor in embryonic and early postnatal rat testis development. *Biol Reprod* **63**, 1617–1628.

- Cupp, A. S., Tessarollo, L., and Skinner, M. K. (2002). Testis developmental phenotypes in neurotrophin receptor *trkA* and *trkC* null mutations: role in formation of seminiferous cords and germ cell survival. *Biol Reprod* **66**, 1838–1845.
- Dani, C., Chambers, I., Johnstone, S., Robertson, M., Ebrahimi, B., Saito, M., Taga, T., Li, M., Burdon, T., Nichols, J., and Smith, A. (1998). Paracrine induction of stem cell renewal by LIF-deficient cells: a new ES cell regulatory pathway. *Dev Biol* **203**, 149–162.
- Davidson, A. J., Freeman, S. A., Crosier, K. E., Wood, C. R., and Crosier, P. S. (1997). Expression of murine interleukin 11 and its receptor alpha-chain in adult and embryonic tissues. *Stem Cells* **15**, 119–124.
- de Miguel, M. P., de Boer-Brouwer, M., de Rooij, D. G., Paniagua, R., and van Dissel-Emiliani, F. M. (1997). Ontogeny and localization of an oncostatin M-like protein in the rat testis: its possible role at the start of spermatogenesis. *Cell Growth Differ* **8**, 611–618.
- De Miguel, M. P., De Boer-Brouwer, M., Paniagua, R., van den Hurk, R., De Rooij, D. G., and Van Dissel-Emiliani, F. M. (1996). Leukemia inhibitory factor and ciliary neurotrophic factor promote the survival of Sertoli cells and gonocytes in coculture system. *Endocrinology* **137**, 1885–1893.
- de Rooij, D. G., and Russell, L. D. (2000). All you wanted to know about spermatogonia but were afraid to ask. *J Androl* **21**, 776–798.
- Dirami, G., Ravindranath, N., Achi, M. V., and Dym, M. (2001). Expression of Notch pathway components in spermatogonia and Sertoli cells of neonatal mice. *J Androl* **22**, 944–952.
- Donovan, M. J., Hahn, R., Tessarollo, L., and Hempstead, B. L. (1996). Identification of an essential nonneuronal function of neurotrophin 3 in mammalian cardiac development. *Nat Genet* **14**, 210–213.
- Dorval-Coiffec, I., Delcros, J. G., Hakovirta, H., Toppari, J., Jegou, B., and Piquet-Pellorce, C. (2005). Identification of the leukemia inhibitory factor cell targets within the rat testis. *Biol Reprod* **72**, 602–611.
- Du, X., Everett, E. T., Wang, G., Lee, W. H., Yang, Z., and Williams, D. A. (1996). Murine interleukin-11 (IL-11) is expressed at high levels in the hippocampus and expression is developmentally regulated in the testis. *J Cell Physiol* **168**, 362–372.
- Dym, M., and Fawcett, D. W. (1970). The blood-testis barrier in the rat and the physiological compartmentation of the seminiferous epithelium. *Biol Reprod* **3**, 308–326.
- Dym, M., and Fawcett, D. W. (1971). Further observations on the numbers of spermatogonia, spermatocytes, and spermatids connected by intercellular bridges in the mammalian testis. *Biol Reprod* **4**, 195–215.
- Enomoto, H., Araki, T., Jackman, A., Heuckeroth, R. O., Snider, W. D., Johnson, E. M. J., and Milbrandt, J. (1998). GFR alpha1-deficient mice have deficits in the enteric nervous system and kidneys. *Neuron* **21**, 317–324.
- Ernst, M., Inglese, M., Waring, P., Campbell, I. K., Bao, S., Clay, F. J., Alexander, W. S., Wicks, I. P., Tarlinton, D. M., Novak, U., Heath, J. K., and Dunn, A. R. (2001). Defective gp130-mediated signal transducer and activator of transcription (STAT) signaling results in degenerative joint disease, gastrointestinal ulceration, and failure of uterine implantation. *J Exp Med* **194**, 189–203.

- Ernst, M., and Jenkins, B. J. (2004). Acquiring signalling specificity from the cytokine receptor gp130. *Trends Genet* **20**, 23–32.
- Girasole, G., Passeri, G., Jilka, R. L., and Manolagas, S. C. (1994). Interleukin-11: a new cytokine critical for osteoclast development. *J Clin Invest* **93**, 1516–1524.
- Golden, J. P., DeMaro, J. A., Osborne, P. A., Milbrandt, J., and Johnson, E. M. J. (1999). Expression of neurturin, GDNF, and GDNF family-receptor mRNA in the developing and mature mouse. *Exp Neurol* **158**, 504–528.
- Goriely, A., McVean, G. A., Rojmyr, M., Ingemarsson, B., and Wilkie, A. O. (2003). Evidence for selective advantage of pathogenic FGFR2 mutations in the male germ line. *Science* **301**, 643–646.
- Griswold, M. D. (1998). The central role of Sertoli cells in spermatogenesis. *Semin Cell Dev Biol* **9**, 411–416.
- Habetswallner, D., Pelosi, E., Bulgarini, D., Camagna, A., Samoggia, P., Montesoro, E., Giannella, G., Lazzaro, D., Isacchi, G., Testa, U., *et al.* (1988). Activation and proliferation of normal resting human T lymphocytes in serum-free culture: role of IL-4 and IL-6. *Immunology* **65**, 357–364.
- Hakovirta, H., Syed, V., Jegou, B., and Parvinen, M. (1995). Function of interleukin-6 as an inhibitor of meiotic DNA synthesis in the rat seminiferous epithelium. *Mol Cell Endocrinol* **108**, 193–198.
- Hallbook, F., Ibanez, C. F., and Persson, H. (1991). Evolutionary studies of the nerve growth factor family reveal a novel member abundantly expressed in *Xenopus* ovary. *Neuron* **6**, 845–858.
- Hara, T., Ichihara, M., Yoshimura, A., and Miyajima, A. (1997). Cloning and biological activity of murine oncostatin M. *Leukemia* **11**(Suppl 3), 449–450.
- Hara, T., Tamura, K., de Miguel, M. P., Mukoyama, Y., Kim, H., Kogo, H., Donovan, P. J., and Miyajima, A. (1998). Distinct roles of oncostatin M and leukemia inhibitory factor in the development of primordial germ cells and Sertoli cells in mice. *Dev Biol* **201**, 144–153.
- Hayashi, T., Kageyama, Y., Ishizaka, K., Xia, G., Kihara, K., and Oshima, H. (2001). Requirement of Notch 1 and its ligand Jagged 2 expressions for spermatogenesis in rat and human testes. *J Androl* **22**, 999–1011.
- Hayashi, T., Yamada, T., Kageyama, Y., Negishi, T., and Kihara, K. (2004). Expression failure of the Notch signaling system is associated with the pathogenesis of maturation arrest in male infertility patients. *Fertil Steril* **81**(3), 697–699.
- Heinrich, P. C., Behrmann, I., Muller-Newen, G., Schaper, F., and Graeve, L. (1998). Interleukin-6-type cytokine signalling through the gp130/Jak/STAT pathway. *Biochem J* **334**, 297–314.
- Helfand, S. L., Smith, G. A., and Wessells, N. K. (1976). Survival and development in culture of dissociated parasymphathetic neurons from ciliary ganglia. *Dev Biol* **50**, 541–547.
- Hellmich, H. L., Kos, L., Cho, E. S., Mahon, K. A., and Zimmer, A. (1996). Embryonic expression of glial cell-line derived neurotrophic factor (GDNF) suggests multiple developmental roles in neural differentiation and epithelial-mesenchymal interactions. *Mech Dev* **54**, 95–105.
- Henderson, C. E., Phillips, H. S., Pollock, R. A., Davies, A. M., Lemeulle, C., Armanini, M., Simmons, L., Moffet, B., Vandlen, R. A., Simpson, L. C. [corrected to Simmons, L.],

- et al.* (1994). GDNF: a potent survival factor for motoneurons present in peripheral nerve and muscle. *Science* **266**, 1062–1064.
- Herrada, G., and Wolgemuth, D. J. (1997). The mouse transcription factor Stat4 is expressed in haploid male germ cells and is present in the perinuclear theca of spermatozoa. *J Cell Sci* **110**, 1543–1553.
- Hirano, T., Nakajima, K., and Hibi, M. (1997). Signaling mechanisms through gp130: a model of the cytokine system. *Cytokine Growth Factor Rev* **8**, 241–252.
- Hirano, T., Yasukawa, K., Harada, H., Taga, T., Watanabe, Y., Matsuda, T., Kashiwamura, S., Nakajima, K., Koyama, K., Iwamatsu, A., *et al.* (1986). Complementary DNA for a novel human interleukin (BSF-2) that induces B lymphocytes to produce immunoglobulin. *Nature* **324**, 73–76.
- Hofmann, M. C., Braydich-Stolle, L., Dettin, L., Johnson, E., and Dym, M. (2005a). Immortalization of mouse germ line stem cells. *Stem Cells* **23**, 200–210.
- Hofmann, M. C., Braydich-Stolle, L., and Dym, M. (2005b). Isolation of male germ-line stem cells; influence of GDNF. *Dev Biol* **279**, 114–124.
- Hohn, A., Leibrock, J., Bailey, K., and Barde, Y. A. (1990). Identification and characterization of a novel member of the nerve growth factor/brain-derived neurotrophic factor family. *Nature* **344**, 339–341.
- Huang, E. J., and Reichardt, L. F. (2003). Trk receptors: roles in neuronal signal transduction. *Annu Rev Biochem* **72**, 609–642.
- Huckins, C. (1971). The spermatogonial stem cell population in adult rats. I. Their morphology, proliferation and maturation. *Anat Rec* **169**, 533–557.
- Huckins, C., and Oakberg, E. F. (1978). Morphological and quantitative analysis of spermatogonia in mouse testes using whole mounted seminiferous tubules. I. The normal testes. *Anat Rec* **192**, 519–528.
- Hudak, S., Thompson-Snipes, L., Rocco, C., Jackson, J., Pearce, M., and Rennick, D. (1992). Anti-IL-6 antibodies suppress myeloid cell production and the generation of CFU-c in long-term bone marrow cultures. *Exp Hematol* **20**, 412–417.
- Hughes, S. M., Lillien, L. E., Raff, M. C., Rohrer, H., and Sendtner, M. (1988). Ciliary neurotrophic factor induces type-2 astrocyte differentiation in culture. *Nature* **335**, 70–73.
- Ihn, H., and Tamaki, K. (2000). Oncostatin M stimulates the growth of dermal fibroblasts via a mitogen-activated protein kinase-dependent pathway. *J Immunol* **165**, 2149–2155.
- Ip, N. Y., Ibanez, C. F., Nye, S. H., McClain, J., Jones, P. F., Gies, D. R., Belluscio, L., Le Beau, M. M., Espinosa, R., 3rd, Squinto, S. P., *et al.* (1992). Mammalian neurotrophin-4: structure, chromosomal localization, tissue distribution, and receptor specificity. *Proc Natl Acad Sci U S A* **89**, 3060–3064.
- Ip, N. Y., Stitt, T. N., Tapley, P., Klein, R., Glass, D. J., Fandl, J., Greene, L. A., Barbacid, M., and Yancopoulos, G. D. (1993). Similarities and differences in the way neurotrophins interact with the Trk receptors in neuronal and nonneuronal cells. *Neuron* **10**, 137–149.
- Jeffery, E., Price, V., and Gearing, D. P. (1993). Close proximity of the genes for leukemia inhibitory factor and oncostatin M. *Cytokine* **5**, 107–111.
- Jeong, D., McLean, D. J., and Griswold, M. D. (2003). Long-term culture and transplantation of murine testicular germ cells. *J Androl* **24**, 661–669.
- Jing, S., Wen, D., Yu, Y., Holst, P. L., Luo, Y., Fang, M., Tamir, R., Antonio, L., Hu, Z., Cupples, R., Louis, J. C., Hu, S., Altrock, B. W., and Fox, G. M. (1996).

- GDNF-induced activation of the ret protein tyrosine kinase is mediated by GDNFR-alpha, a novel receptor for GDNF. *Cell* **85**, 1113–1124.
- Johnson, D., Lanahan, A., Buck, C. R., Sehgal, A., Morgan, C., Mercer, E., Bothwell, M., and Chao, M. (1986). Expression and structure of the human NGF receptor. *Cell* **47**, 545–554.
- Kanatsu-Shinohara, M., Inoue, K., Lee, J., Yoshimoto, M., Ogonuki, N., Miki, H., Baba, S., Kato, T., Kazuki, Y., Toyokuni, S., Toyoshima, M., Niwa, O., Oshimura, M., Heike, T., Nakahata, T., Ishino, F., Ogura, A., and Shinohara, T. (2004). Generation of pluripotent stem cells from neonatal mouse testis. *Cell* **119**, 1001–1012.
- Kanatsu-Shinohara, M., Ogonuki, N., Inoue, K., Miki, H., Ogura, A., Toyokuni, S., and Shinohara, T. (2003). Long-term proliferation in culture and germline transmission of mouse male germline stem cells. *Biol Reprod* **69**, 612–616.
- Kaplan, D. R., and Miller, F. D. (1997). Signal transduction by the neurotrophin receptors. *Curr Opin Cell Biol* **9**, 213–221.
- Kawashima, I., Ohsumi, J., Mita-Honjo, K., Shimoda-Takano, K., Ishikawa, H., Sakakibara, S., Miyadai, K., and Takiguchi, Y. (1991). Molecular cloning of cDNA encoding adipogenesis inhibitory factor and identity with interleukin-11. *FEBS Lett* **283**, 199–202.
- Keller, D. C., Du, X. X., Srour, E. F., Hoffman, R., and Williams, D. A. (1993). Interleukin-11 inhibits adipogenesis and stimulates myelopoiesis in human long-term marrow cultures. *Blood* **82**, 1428–1435.
- Kiuchi, N., Nakajima, K., Ichiba, M., Fukada, T., Narimatsu, M., Mizuno, K., Hibi, M., and Hirano, T. (1999). STAT3 is required for the gp130-mediated full activation of the c-myc gene. *J Exp Med* **189**, 63–73.
- Klein, R., Conway, D., Parada, L. F., and Barbacid, M. (1990). The trkB tyrosine protein kinase gene codes for a second neurogenic receptor that lacks the catalytic kinase domain. *Cell* **61**, 647–656.
- Klein, R., Jing, S. Q., Nanduri, V., O'Rourke, E., and Barbacid, M. (1991a). The trk proto-oncogene encodes a receptor for nerve growth factor. *Cell* **65**, 189–197.
- Klein, R., Nanduri, V., Jing, S. A., Lamballe, F., Tapley, P., Bryant, S., Cordon-Cardo, C., Jones, K. R., Reichardt, L. F., and Barbacid, M. (1991b). The trkB tyrosine protein kinase is a receptor for brain-derived neurotrophic factor and neurotrophin-3. *Cell* **66**, 395–403.
- Kolbeck, R., Jungbluth, S., and Barde, Y. A. (1994). Characterisation of neurotrophin dimers and monomers. *Eur J Biochem* **225**, 995–1003.
- Kubota, H., Avarbock, M. R., and Brinster, R. L. (2004). Culture conditions and single growth factors affect fate determination of mouse spermatogonial stem cells. *Biol Reprod* **71**, 722–731.
- Lamballe, F., Klein, R., and Barbacid, M. (1991). trkC, a new member of the trk family of tyrosine protein kinases, is a receptor for neurotrophin-3. *Cell* **66**, 967–979.
- Lee, R. H., Wong, W. L., Chan, C. H., and Chan, S. Y. (2006). Differential effects of glial cell line-derived neurotrophic factor and neurturin in RET/GFRalpha1-expressing cells. *J Neurosci Res* **83**, 80–90.
- Leibrock, J., Lottspeich, F., Hohn, A., Hofer, M., Hengerer, B., Masiakowski, P., Thoenen, H., and Barde, Y. A. (1989). Molecular cloning and expression of brain-derived neurotrophic factor. *Nature* **341**, 149–152.

- Levine, E., Cupp, A. S., and Skinner, M. K. (2000). Role of neurotrophins in rat embryonic testis morphogenesis (cord formation). *Biol Reprod* **62**, 132–142.
- Lin, L. F., Doherty, D. H., Lile, J. D., Bektesh, S., and Collins, F. (1993). GDNF: a glial cell line-derived neurotrophic factor for midbrain dopaminergic neurons. *Science* **260**, 1130–1132.
- Luzzi, A., Angeletti, P. U., and Levi-Montalcini, R. (1965). Metabolic effects of a specific nerve growth factor (NGF) on sensory and sympathetic ganglia: enhancement of lipid biosynthesis. *J Neurochem* **12**, 705–708.
- Maier, R., Ganu, V., and Lotz, M. (1993). Interleukin-11, an inducible cytokine in human articular chondrocytes and synoviocytes, stimulates the production of the tissue inhibitor of metalloproteinases. *J Biol Chem* **268**, 21527–21532.
- Maisonpierre, P. C., Belluscio, L., Squinto, S., Ip, N. Y., Furth, M. E., Lindsay, R. M., and Yancopoulos, G. D. (1990). Neurotrophin-3: a neurotrophic factor related to NGF and BDNF. *Science* **247**, 1446–1451.
- Matsui, Y., Toksoz, D., Nishikawa, S., Nishikawa, S., Williams, D., Zsebo, K., and Hogan, B. L. (1991). Effect of Steel factor and leukaemia inhibitory factor on murine primordial germ cells in culture. *Nature* **353**, 750–752.
- Matsui, Y., Zsebo, K., and Hogan, B. L. (1992). Derivation of pluripotential embryonic stem cells from murine primordial germ cells in culture. *Cell* **70**, 841–847.
- McGill, M. A., and McGlade, C. J. (2003). Mammalian numb proteins promote Notch1 receptor ubiquitination and degradation of the Notch1 intracellular domain. *J Biol Chem* **278**, 23196–23203.
- Meng, X., de Rooij, D. G., Westerdahl, K., Saarma, M., and Sariola, H. (2001a). Promotion of seminomatous tumors by targeted overexpression of glial cell line-derived neurotrophic factor in mouse testis. *Cancer Res* **61**, 3267–3271.
- Meng, X., Lindahl, M., Hyvonen, M. E., Parvinen, M., de Rooij, D. G., Hess, M. W., Raatikainen-Ahokas, A., Sainio, K., Rauvala, H., Lakso, M., Pichel, J. G., Westphal, H., Saarma, M., and Sariola, H. (2000). Regulation of cell fate decision of undifferentiated spermatogonia by GDNF. *Science* **287**, 1489–1493.
- Meng, X., Pata, I., Pedrono, E., Popsueva, A., de Rooij, D. G., Janne, M., Rauvala, H., and Sariola, H. (2001b). Transient disruption of spermatogenesis by deregulated expression of neurturin in testis. *Mol Cell Endocrinol* **184**, 33–39.
- Metcalf, D. (2003). The unsolved enigmas of leukemia inhibitory factor. *Stem Cells* **21**, 5–14.
- Metz, M., Botchkarev, V. A., Botchkareva, N. V., Welker, P., Tobin, D. J., Knop, J., Maurer, M., and Paus, R. (2004). Neurotrophin-3 regulates mast cell functions in neonatal mouse skin. *Exp Dermatol* **13**, 273–281.
- Miles, S. A., Martinez-Maza, O., Rezaei, A., Magpantay, L., Kishimoto, T., Nakamura, S., Radka, S. F., and Linsley, P. S. (1992). Oncostatin M as a potent mitogen for AIDS-Kaposi's sarcoma-derived cells. *Science* **255**, 1432–1434.
- Moore, M. W., Klein, R. D., Farinas, I., Sauer, H., Armanini, M., Phillips, H., Reichardt, L. F., Ryan, A. M., Carver-Moore, K., and Rosenthal, A. (1996). Renal and neuronal abnormalities in mice lacking GDNF. *Nature* **382**, 76–79.
- Munoz-Fernandez, M. A., and Fresno, M. (1998). The role of tumour necrosis factor, interleukin 6, interferon-gamma and inducible nitric oxide synthase in the development and pathology of the nervous system. *Prog Neurobiol* **56**, 307–340.

- Myers, S. M., Eng, C., Ponder, B. A., and Mulligan, L. M. (1995). Characterization of RET proto-oncogene 3' splicing variants and polyadenylation sites: a novel C-terminus for RET. *Oncogene* **11**, 2039–2045.
- Nakamura, K., Nonaka, H., Saito, H., Tanaka, M., and Miyajima, A. (2004). Hepatocyte proliferation and tissue remodeling is impaired after liver injury in oncostatin M receptor knockout mice. *Hepatology* **39**, 635–644.
- Naughton, C. K., Jain, S., Strickland, A. M., Gupta, A., and Milbrandt, J. (2006). Glial cell-line derived neurotrophic factor (GDNF)-mediated RET signaling regulates spermatogonial stem cell fate. *Biol Reprod* **74**, 314–321.
- Nguyen, Q. T., Parsadanian, A. S., Snider, W. D., and Lichtman, J. W. (1998). Hyperinnervation of neuromuscular junctions caused by GDNF overexpression in muscle. *Science* **279**, 1725–1729.
- Nikolova, D. B., Martinova, Y. S., Seidensticker, M., and Bellve, A. R. (1997). Leukaemia inhibitory factor stimulates proliferation of prospermatogonial stem cells. *Reprod Fertil Dev* **9**, 717–721.
- Nykjaer, A., Willnow, T. E., and Petersen, C. M. (2005). p75^{NTR} — live or let die. *Curr Opin Neurobiol* **15**, 49–57.
- Oakberg, E. F. (1971). Spermatogonial stem-cell renewal in the mouse. *Anat Rec* **169**, 515–531.
- Ohara, O., Gahara, Y., Teraoka, H., and Kitamura, T. (1992). A rat brain-derived neurotrophic factor-encoding gene generates multiple transcripts through alternative use of 5' exons and polyadenylation sites. *Gene* **121**, 383–386.
- Olson, L., Ayer-LeLievre, C., Ebendal, T., and Seiger, A. (1987). Nerve growth factor-like immunoreactivities in rodent salivary glands and testis. *Cell Tissue Res* **248**, 275–286.
- Onoda, M., Pflug, B., and Djakiew, D. (1991). Germ cell mitogenic activity is associated with nerve growth factor-like protein(s). *J Cell Physiol* **149**, 536–543.
- Paratcha, G., Ledda, F., and Ibanez, C. F. (2003). The neural cell adhesion molecule NCAM is an alternative signaling receptor for GDNF family ligands. *Cell* **113**, 867–879.
- Park, C., Choi, W. S., Kwon, H., and Kwon, Y. K. (2001). Temporal and spatial expression of neurotrophins and their receptors during male germ cell development. *Mol Cells* **12**, 360–367.
- Parvinen, M., Pelto-Huikko, M., Soder, O., Schultz, R., Kaipia, A., Mali, P., Toppari, J., Hakovirta, H., Lonnerberg, P., Ritzen, E. M., *et al.* (1992). Expression of beta-nerve growth factor and its receptor in rat seminiferous epithelium: specific function at the onset of meiosis. *J Cell Biol* **117**, 629–641.
- Paul, S. R., Bennett, F., Calvetti, J. A., Kelleher, K., Wood, C. R., O'Hara, R. M. J., Leary, A. C., Sibley, B., Clark, S. C., Williams, D. A., *et al.* (1990). Molecular cloning of a cDNA encoding interleukin 11, a stromal cell-derived lymphopoietic and hematopoietic cytokine. *Proc Natl Acad Sci U S A* **87**, 7512–7516.
- Persson, H., Ayer-LeLievre, C., Soder, O., Villar, M. J., Metsis, M., Olson, L., Ritzen, M., and Hokfelt, T. (1990). Expression of beta-nerve growth factor receptor mRNA in Sertoli cells downregulated by testosterone. *Science* **247**, 704–707.
- Pesce, M., Farrace, M. G., Piacentini, M., Dolci, S., and De Felici, M. (1993). Stem cell factor and leukemia inhibitory factor promote primordial germ cell survival by suppressing programmed cell death (apoptosis). *Development* **118**, 1089–1094.

- Peterziel, H., Unsicker, K., and Kriegelstein, K. (2002). TGFbeta induces GDNF responsiveness in neurons by recruitment of GFRalpha1 to the plasma membrane. *J Cell Biol* **159**, 157–167.
- Pichel, J. G., Shen, L., Sheng, H. Z., Granholm, A. C., Drago, J., Grinberg, A., Lee, E. J., Huang, S. P., Saarma, M., Hoffer, B. J., Sariola, H., and Westphal, H. (1996). Defects in enteric innervation and kidney development in mice lacking GDNF. *Nature* **382**, 73–76.
- Piquet-Pellorce, C., Dorval-Coiffec, I., Pham, M. D., and Jegou, B. (2000). Leukemia inhibitory factor expression and regulation within the testis. *Endocrinology* **141**, 1136–1141.
- Popsueva, A., Poteryaev, D., Arighi, E., Meng, X., Angers-Loustau, A., Kaplan, D., Saarma, M., and Sariola, H. (2003). GDNF promotes tubulogenesis of GFRalpha1-expressing MDCK cells by Src-mediated phosphorylation of Met receptor tyrosine kinase. *J Cell Biol* **161**, 119–129.
- Potashnik, H., Elhija, M. A., Lunenfeld, E., Potashnik, G., Schlatt, S., Nieschlag, E., and Huleihel, M. (2005). Interleukin-6 expression during normal maturation of the mouse testis. *Eur Cytokine Netw* **16**, 161–165.
- Resnick, J. L., Bixler, L. S., Cheng, L., and Donovan, P. J. (1992). Long-term proliferation of mouse primordial germ cells in culture [see comments]. *Nature* **359**, 550–551.
- Robb, L., Li, R., Hartley, L., Nandurkar, H. H., Koentgen, F., and Begley, C. G. (1998). Infertility in female mice lacking the receptor for interleukin 11 is due to a defective uterine response to implantation. *Nat Med* **4**, 303–308.
- Robinson, L. L., Townsend, J., and Anderson, R. A. (2003). The human fetal testis is a site of expression of neurotrophins and their receptors: regulation of the germ cell and peritubular cell population. *J Clin Endocrinol Metab* **88**, 3943–3951.
- Rose, T. M., and Bruce, A. G. (1991). Oncostatin M is a member of a cytokine family that includes leukemia-inhibitory factor, granulocyte colony-stimulating factor, and interleukin 6. *Proc Natl Acad Sci U S A* **88**, 8641–8645.
- Rose, T. M., Lagrou, M. J., Fransson, I., Werelius, B., Delattre, O., Thomas, G., de Jong, P. J., Todaro, G. J., and Dumanski, J. P. (1993). The genes for oncostatin M (OSM) and leukemia inhibitory factor (LIF) are tightly linked on human chromosome 22. *Genomics* **17**, 136–140.
- Roux, P. P., and Barker, P. A. (2002). Neurotrophin signaling through the p75 neurotrophin receptor. *Prog Neurobiol* **67**, 203–233.
- Russell, L. D., Tallon-Doran, M., Weber, J. E., Wong, V., and Peterson, R. N. (1983). Three-dimensional reconstruction of a rat stage V Sertoli cell: III. A study of specific cellular relationships. *Am J Anat* **167**, 181–192.
- Saadat, S., Sendtner, M., and Rohrer, H. (1989). Ciliary neurotrophic factor induces cholinergic differentiation of rat sympathetic neurons in culture. *J Cell Biol* **108**, 1807–1816.
- Sanchez, M. P., Silos-Santiago, I., Frisen, J., He, B., Lira, S. A., and Barbacid, M. (1996). Renal agenesis and the absence of enteric neurons in mice lacking GDNF. *Nature* **382**, 70–73.
- Sariola, H. (2001). The neurotrophic factors in non-neuronal tissues. *Cell Mol Life Sci* **58**, 1061–1066.
- Sariola, H., and Meng, X. (2003). GDNF-induced seminomatous tumours in mouse — an experimental model for human seminomas? *APMIS* **111**, 192–196; discussion 196.

- Sariola, H., and Saarma, M. (2003). Novel functions and signalling pathways for GDNF. *J Cell Sci* **116**, 3855–3862.
- Schuchardt, A., D'Agati, V., Larsson-Blomberg, L., Costantini, F., and Pachnis, V. (1994). Defects in the kidney and enteric nervous system of mice lacking the tyrosine kinase receptor Ret. *Nature* **367**, 380–383.
- Schultz, R., Metsis, M., Hokfelt, T., Parvinen, M., and Peltö-Huikko, M. (2001). Expression of neurotrophin receptors in rat testis. Upregulation of TrkA mRNA with hCG treatment. *Mol Cell Endocrinol* **182**, 121–127.
- Segal, R. A. (2003). Selectivity in neurotrophin signaling: theme and variations. *Annu Rev Neurosci* **26**, 299–330.
- Segouffin-Cariou, C., and Billaud, M. (2000). Transforming ability of MEN2A-RET requires activation of the phosphatidylinositol 3-kinase/AKT signaling pathway. *J Biol Chem* **275**, 3568–3576.
- Sendtner, M., Schmalbruch, H., Stockli, K. A., Carroll, P., Kreutzberg, G. W., and Thoenen, H. (1992). Ciliary neurotrophic factor prevents degeneration of motor neurons in mouse mutant progressive motor neuropathy. *Nature* **358**, 502–504.
- Skinner, M. K. (2005a). Sertoli cell-secreted regulatory factors. In: *Sertoli Cell Biology*, M. K. Skinner & M. D. Griswold, eds., Elsevier Science (U S A), San Diego, pp. 107–120.
- Skinner, M. K. (2005b). Sertoli cell-somatic cell interactions. In: *Sertoli Cell Biology*, M. K. Skinner & M. D. Griswold, eds., Elsevier Science (U S A), San Diego, pp. 317–328.
- Smith, A. G., Heath, J. K., Donaldson, D. D., Wong, G. G., Moreau, J., Stahl, M., and Rogers, D. (1988). Inhibition of pluripotential embryonic stem cell differentiation by purified polypeptides. *Nature* **336**, 688–690.
- Stephan, J. P., Syed, V., and Jegou, B. (1997). Regulation of Sertoli cell IL-1 and IL-6 production in vitro. *Mol Cell Endocrinol* **134**, 109–118.
- Stewart, C. L., Gadi, I., and Bhatt, H. (1994). Stem cells from primordial germ cells can reenter the germ line. *Dev Biol* **161**, 626–628.
- Stewart, C. L., Kaspar, P., Brunet, L. J., Bhatt, H., Gadi, I., Kontgen, F., and Abbondanzo, S. J. (1992). Blastocyst implantation depends on maternal expression of leukaemia inhibitory factor. *Nature* **359**, 76–79.
- Stockli, K. A., Lottspeich, F., Sendtner, M., Masiakowski, P., Carroll, P., Gotz, R., Lindholm, D., and Thoenen, H. (1989). Molecular cloning, expression and regional distribution of rat ciliary neurotrophic factor. *Nature* **342**, 920–923.
- Takahashi, M., Ritz, J., and Cooper, G. M. (1985). Activation of a novel human transforming gene, ret, by DNA rearrangement. *Cell* **42**, 581–588.
- Tamura, S., Morikawa, Y., and Senba, E. (2003). Localization of oncostatin M receptor beta in adult and developing CNS. *Neuroscience* **119**, 991–997.
- Tamura, S., Morikawa, Y., Tanaka, M., Miyajima, A., and Senba, E. (2002). Developmental expression pattern of oncostatin M receptor beta in mice. *Mech Dev* **115**, 127–131.
- Tanaka, M., Hirabayashi, Y., Sekiguchi, T., Inoue, T., Katsuki, M., and Miyajima, A. (2003). Targeted disruption of oncostatin M receptor results in altered hematopoiesis. *Blood* **102**, 3154–3162.
- Timmusk, T., Belluardo, N., Metsis, M., and Persson, H. (1993a). Widespread and developmentally regulated expression of neurotrophin-4 mRNA in rat brain and peripheral tissues. *Eur J Neurosci* **5**, 605–613.

- Timmusk, T., Palm, K., Metsis, M., Reintam, T., Paalme, V., Saarma, M., and Persson, H. (1993b). Multiple promoters direct tissue-specific expression of the rat BDNF gene. *Neuron* **10**, 475–489.
- Tomac, A. C., Grinberg, A., Huang, S. P., Nosrat, C., Wang, Y., Borlongan, C., Lin, S. Z., Chiang, Y. H., Olson, L., Westphal, H., and Hoffer, B. J. (2000). Glial cell line-derived neurotrophic factor receptor alpha 1 availability regulates glial cell line-derived neurotrophic factor signaling: evidence from mice carrying one or two mutated alleles. *Neuroscience* **95**, 1011–1023.
- Treanor, J. J., Goodman, L., de Sauvage, F., Stone, D. M., Poulsen, K. T., Beck, C. D., Gray, C., Armanini, M. P., Pollock, R. A., Hefti, F., Phillips, H. S., Goddard, A., Moore, M. W., Buj-Bello, A., Davies, A. M., Asai, N., Takahashi, M., Vandlen, R., Henderson, C. E., and Rosenthal, A. (1996). Characterization of a multicomponent receptor for GDNF. *Nature* **382**, 80–83.
- Trupp, M., Ryden, M., Jornvall, H., Funakoshi, H., Timmusk, T., Arenas, E., and Ibanez, C. F. (1995). Peripheral expression and biological activities of GDNF, a new neurotrophic factor for avian and mammalian peripheral neurons. *J Cell Biol* **130**, 137–148.
- Turner, K. J., and Clark, S. C. (1995). Interleukin-11: biological and clinical perspectives. In: *Hematopoietic Growth Factors in Clinical Applications*, R. Mertelsmann & F. Herrmann, eds., Marcel Dekker, Inc., New York, pp. 315–336.
- Viglietto, G., Dolci, S., Bruni, P., Baldassarre, G., Chiariotti, L., Melillo, R. M., Salvatore, G., Chiappetta, G., Sfratore, F., Fusco, A., and Santoro, M. (2000). Glial cell line-derived neurotrophic factor and neurturin can act as paracrine growth factors stimulating DNA synthesis of Ret-expressing spermatogonia. *Int J Oncol* **16**, 689–694.
- Ware, C. B., Horowitz, M. C., Renshaw, B. R., Hunt, J. S., Liggitt, D., Koblar, S. A., Gliniak, B. C., McKenna, H. J., Papayannopoulou, T., Thoma, B., *et al.* (1995). Targeted disruption of the low-affinity leukemia inhibitory factor receptor gene causes placental, skeletal, neural and metabolic defects and results in perinatal death. *Development* **121**, 1283–1299.
- Weinmaster, G. (1997). The ins and outs of notch signaling. *Mol Cell Neurosci* **9**, 91–102.
- Williams, R. L., Hilton, D. J., Pease, S., Willson, T. A., Stewart, C. L., Gearing, D. P., Wagner, E. F., Metcalf, D., Nicola, N. A., and Gough, N. M. (1988). Myeloid leukaemia inhibitory factor maintains the developmental potential of embryonic stem cells. *Nature* **336**, 684–687.
- Wong, V., and Russell, L. D. (1983). Three-dimensional reconstruction of a rat stage V Sertoli cell: I. Methods, basic configuration, and dimensions. *Am J Anat* **167**, 143–161.
- Woo, C. W., Lucarelli, E., and Thiele, C. J. (2004). NGF activation of TrkA decreases N-myc expression via MAPK path leading to a decrease in neuroblastoma cell number. *Oncogene* **23**, 1522–1530.
- Worby, C. A., Vega, Q. C., Zhao, Y., Chao, H. H., Seasholtz, A. F., and Dixon, J. E. (1996). Glial cell line-derived neurotrophic factor signals through the RET receptor and activates mitogen-activated protein kinase. *J Biol Chem* **271**, 23619–23622.
- Yoshida, K., Taga, T., Saito, M., Suematsu, S., Kumanogoh, A., Tanaka, T., Fujiwara, H., Hirata, M., Yamagami, T., Nakahata, T., Hirabayashi, T., Yoneda, Y., Tanaka, K., Wang, W. Z., Mori, C., Shiota, K., Yoshida, N., and Kishimoto, T. (1996). Targeted disruption of gp130, a common signal transducer for the interleukin 6 family of cytokines, leads to myocardial and hematological disorders. *Proc Natl Acad Sci U S A* **93**, 407–411.

- Zarling, J. M., Shoyab, M., Marquardt, H., Hanson, M. B., Lioubin, M. N., and Todaro, G. J. (1986). Oncostatin M: a growth regulator produced by differentiated histiocytic lymphoma cells. *Proc Natl Acad Sci U S A* **83**, 9739–9743.
- Zhang, S. H., Zhou, X. F., Deng, Y. S., and Rush, R. A. (1999). Measurement of neurotrophin 4/5 in rat tissues by a sensitive immunoassay. *J Neurosci Methods* **89**, 69–74.
- Zurn, A. D., Winkel, L., Menoud, A., Djabali, K., and Aebischer, P. (1996). Combined effects of GDNF, BDNF, and CNTF on motoneuron differentiation in vitro. *J Neurosci Res* **44**, 133–141.
- Zwick, M., Molliver, D. C., Lindsay, J., Fairbanks, C. A., Sengoku, T., Albers, K. M., and Davis, B. M. (2003). Transgenic mice possessing increased numbers of nociceptors do not exhibit increased behavioral sensitivity in models of inflammatory and neuropathic pain. *Pain* **106**, 491–500.

CHAPTER 8

DICKKOPF-LIKE 1 — A PROTEIN UNIQUE TO MAMMALS THAT IS ASSOCIATED BOTH WITH FORMATION OF TROPHOBLAST STEM CELLS AND WITH SPERMATOGENESIS

Matthew J. Kohn*, Kotaro J. Kaneko*, Rieko Yagi*, Eveline S. Litscher†, Paul M. Wassarman†, and Melvin L. DePamphilis*

**National Institute of Child Health and Human Development,
National Institutes of Health,
Bethesda, MD*

*†Department of Molecular, Cell and Developmental Biology,
Mount Sinai School of Medicine,
New York, NY*

Dickkopf-like 1 (Dkk1) is related to a group of secreted proteins that are antagonists of *Wingless* (Wnt) signal transduction pathways. The *Dkk1* gene is found only in mammals, where it is closely linked to the transcription factor *Tead2*; both genes are among the first to be expressed at the beginning of mouse development. In cells derived from preimplantation embryos, the *Dkk1* gene is selectively expressed in trophoblast stem cells and repressed in embryonic stem cells. Thus, *Dkk1* appears to be required in the placental lineage, where it appears in the trophoctoderm and eventually in the trophoblast giant cells that are involved in implantation, but is toxic to the embryonic lineage. In adult mammals, *Dkk1* is expressed predominantly (although not exclusively) during the formation of the male germ cells, where it eventually localizes to the acrosome of mature sperm. Following capacitation, some of the *Dkk1* protein migrates to the surface of the sperm, where it may be involved in fertilization. Thus, *Dkk1* is involved in two seemingly unrelated functions: the production of sperm, and the production of trophoctoderm cells and their derivatives.

Keywords: Dickkopf-like 1; *Dkk1*; spermatogenesis; acrosome; trophoblast.

The Role of Dickkopf Genes in the Regulation of Animal Development

Mammals contain a unique gene called *Dickkopf-like 1* (*Dkk1*). *Dkk1* [originally termed *Soggy* (*Sgy*)] was discovered independently first by searching for human *Dickkopf* (*Dkk*) family members (Krupnik et al., 1999), and second by analysis of DNA sequences upstream of the mouse *Tead2* gene (Kaneko and DePamphilis, 2000). Mammals contain four *Dkk* genes (Krupnik et al., 1999). These genes were originally identified in *Xenopus*, where *XIDkk1* induces the Spemann's organizer that forms head tissue (Glinka et al., 1998). The injection of *XIDkk1* mRNA induces head formation in combination with another set of factors that inhibit bone morphogenetic proteins (BMPs), while the depletion of *XIDkk1* with antibodies causes microcephaly. Hence, *XIDkk1* is a potent inducer of head formation; thus the name *Dickkopf*, which is German for "fat head".

Dkk proteins are antagonists of the signal transduction protein called Wingless (Wnt). Wnt proteins are secreted glycoproteins that mediate cell proliferation and fate determination in both adults and embryos. They also mediate axis formation during development, induce proper development of the central nervous system, and are involved in tumorigenesis (reviewed in Nelson and Nusse, 2004). Activation of the Wnt signaling pathway results in accumulation of the transcription factor β -catenin in the cell nucleus, thereby activating transcription.

Wnt proteins bind to transmembrane receptors called Frizzled (Fz), as well as to low-density lipoprotein receptor-related proteins (LRP) (Fig. 1). Binding of Wnt to Fz receptors recruits and activates the phosphoprotein Disheveled, which in turn prevents glycogen synthase kinase 3b (GSK3b)-dependent phosphorylation of β -catenin. Phosphorylation of β -catenin leads to its ubiquitin-mediated degradation (reviewed in Dominguez and Green, 2001). Therefore, inactivation of GSK3b allows the stabilization of β -catenin and its translocation to the nucleus. Once in the nucleus, β -catenin interacts with its partner LEF/TCF (lymphoid enhancer factor/T-cell factor), thereby relaying Wnt signaling to the oncogenes c-Myc and cyclin D1 as well as activating axin and conductin. Axin and conductin separately form a complex with GSK3b/ β -catenin/APC (adenomatous polyposis coli) resulting in a negative feedback loop, as both are also LEF/TCF targets.

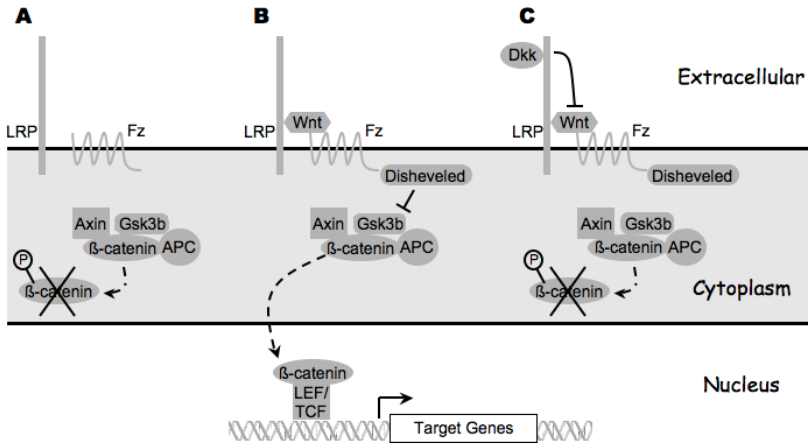

Fig. 1. Wnt signaling and the roles of Dickkopf proteins. **A.** In the absence of Wnt signaling, GSK3b (in complex with axin and APC) phosphorylates β -catenin, thereby causing ubiquitin-mediated degradation of β -catenin. **B.** Secreted Wnt proteins bind to the Fz receptor, which then recruits Disheveled. Disheveled inhibits the kinase activity of GSK3b, preventing it from phosphorylating β -catenin. β -catenin is then translocated to the nucleus, where it interacts with the transcription factor LEF/TCF, activating the transcription of LEF/TCF-dependent target genes (including the oncogenes *c-Myc* and *cyclin D1*). **C.** The Dkk proteins bind to LRP receptors and inhibit Wnt signaling by inducing endocytosis of the receptor complex. This allows GSK3b to resume phosphorylating β -catenin, leading to its degradation and preventing (further) activation of LEF/TCF target genes.

Dkk proteins are thought to prevent Wnt signaling by binding to the LRP receptors (reviewed in Miller, 2002). Interaction of a Dkk protein with LRP causes LRP endocytosis, which prevents formation of an LRP/Wnt/Fz complex, thereby leading to degradation of β -catenin (Mao *et al.*, 2002). For example, XIDkk1 is a secreted antagonist of XIWnt8, an axis-inducing Wnt family member, and the inhibition of XIWnt8 activity allows proper head formation. Similarly, mammalian Dkk1 is a potent antagonist of Wnt signaling, from inducing head formation in the *Xenopus* embryo (Glinka *et al.*, 1998) to the induction of cardiogenesis ectopically in both chick and *Xenopus* embryos (Marvin *et al.*, 2001; Schneider and Mercola, 2001). *In vivo* Dkk1 can prevent Wnt-dependent upregulation of β -catenin, and reduce endogenous levels in some cancer cell lines while inducing the expression of markers of differentiation (Bafico *et al.*, 2004). In *Xenopus*, both Dkk1 and Dkk4 can inhibit the axis-inducing activity of XIWnt8 (Glinka *et al.*, 1998; Krupnik *et al.*, 1999).

However, unlike Dkk1 and Dkk4, Dkk2 and Dkk3 are unable to inhibit XIWnt8. Moreover, Dkk2 actually stimulates expression of the Wnt target genes in some situations (Krupnik *et al.*, 1999; Wu *et al.*, 2000); and ectopic expression of Dkk2 in *Xenopus* causes microcephaly (Wu *et al.*, 2000), the opposite effect of Dkk1 (Glinka *et al.*, 1998). In mammals, however, Dkk2 does antagonize Wnt by inhibiting Wnt signaling through the LRP6 receptor, an activity that can be modulated by an additional receptor, Kremen2 (Mao *et al.*, 2002). Interestingly, while Kremen2 enhances Wnt signaling by binding and repressing Dkk2, it synergizes with Dkk1 to further repress Wnt signals (Davidson *et al.*, 2002).

Expression of Dickkopf Genes During Mammalian Development

Embryonic day 3.5 (E3.5) in mouse development sees the formation of blastocysts, the first developmental stage in which two distinct cell lineages are clearly recognizable. Only *MmDkk1* is expressed in blastocysts, but *MmDkk3* and *MmDkk4* are transcribed after embryos implant at E5.5 (Kemp *et al.*, 2005). *MmDkk1* is expressed several days later in development in the visceral anterior endoderm of the embryos, where it likely reprises the role of *XIDkk1* in inducing head formation. *HsDkk2* and *HsDkk3* are expressed in a variety of tissues, including the cardiac muscle, central nervous system, placenta, and lung. Mice lacking the *Dkk2* gene are viable and fertile; but they have significantly reduced bone mineral density, leading to osteopenia (Li *et al.*, 2002; Li *et al.*, 2005). *HsDkk1* is expressed predominantly in placenta (Krupnik *et al.*, 1999). *HsDkk4* mRNA has not been detected in any human tissues, although *HsDkk4* appears in several human tissue cDNA libraries.

HsDKK3 is found downregulated in a number of tumors (Kurose *et al.*, 2004) and — upon overexpression in osteosarcoma cells — is able to suppress invasion and motility *in vitro*, suggesting that repression of *HsDkk3* may correlate with metastasis (Hoang *et al.*, 2004). The decreased motility observed in osteosarcoma cells upon overexpression correlates with the relocalization of β -catenin from the nucleus to the cell membrane. Whether HsDKK3 exerts its effects directly through the Wnt pathway or circumvents it to affect β -catenin localization remains unclear.

Dkk1

Dkk1 is unique to mammals. *MmDkk1* encodes a 230-amino-acid protein that is highly conserved between mammalian species (Kaneko and DePamphilis, 2000). For example, *MmDkk1* and *HsDKKL1* are 62% identical. All four Dkk proteins contain N-terminal signal peptides, suggesting that they are all secreted (Glinka *et al.*, 1998; Krupnik *et al.*, 1999) (Fig. 2). Dkk1 shares this motif, and the ectopic expression of tagged *HsDKK1*–4 and *HsDKKL1* proteins in cultured cells confirmed that all five proteins are indeed secreted (Krupnik *et al.*, 1999).

In all four *HsDKK* proteins, the signal peptide is followed by two highly conserved cysteine-rich regions, each of which has ten cysteines. The second cysteine-rich region, which is the most conserved, bears similarity to members of the colipase family and is possibly the domain responsible for interaction with LRP6 (Li *et al.*, 2002). Dkk1 shares the greatest homology with the N-terminal region of Dkk3, continuing through the cysteine-rich domains, although it completely lacks the actual cysteine residues. *HsDKK1* has a single potential asparagine-linked glycosylation (N-glycosylation) site at the C-terminus (Krupnik *et al.*, 1999), and Dkk2 has a single N-glycosylation site at the N-terminus (Katoh and Katoh, 2005). Both Dkk1 and Dkk3 also contain several potential N-glycosylation sites that are conserved between the two proteins in both humans and mice. *HsDKK3* and *HsDKKL1* are indeed both N-glycosylated when overexpressed in tissue culture cells, although *HsDKK1* and *HsDKK2* are not. Moreover, Dkk1, like its Dkk counterparts, appears to play critical roles

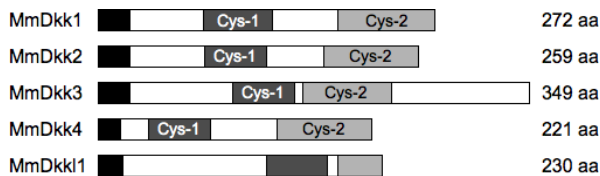

Fig. 2. The mouse Dickkopf gene family. The four members of the mammalian Dickkopf family, along with the related Dickkopf-like 1 (Dkk1), share an N-terminal peptide sequence (black boxes) thought to drive secretion of the mature protein. The Dkk proteins also share two conserved domains that each contains 10 cysteine residues, termed the cysteine-rich domains (Cys-1, medium gray box; and Cys-2, light gray box). Dkk1 also contains these domains, except that none of the cysteine residues are present.

in mammalian development: the establishment of trophoblast cell lineages, and the production of sperm.

Differential Expression of *Dkk11* and *Tead2* Genes

Mammals express four highly conserved TEA domain (*Tead*) transcription factors that share a similar DNA-binding domain, but that are expressed in a variety of different tissues where, in the presence of a transcriptional coactivator, they activate specific genes (reviewed in Vassilev *et al.*, 2001). *Tead2* is the only *Tead* gene expressed in mouse embryos during the first 7 days of development (Kaneko *et al.*, 1997; Wang and Latham, 2000), suggesting that it plays a unique role at the beginning of mammalian development. This advanced expression of *Tead2* allows preimplantation mouse embryos and embryonic stem (ES) cells to utilize *Tead*-dependent promoters and enhancers (Kaneko *et al.*, 1997; Martinez-Salas *et al.*, 1989; Melin *et al.*, 1993).

During mouse development, both *Tead2* and *Dkk11* mRNAs are synthesized at comparable levels after the onset of zygotic gene expression at the 2-cell stage, and their expression continues through the blastocyst stage where they are expressed in two different cell types (Kaneko *et al.*, 2004). E3.5 blastocysts consist of an inner cell mass (ICM) that will become the embryo, and are surrounded by a cell monolayer (the trophectoderm) that will form most of the placenta (Stewart, 2000) (Fig. 3). ES cells can be derived from the ICM, and trophoblast stem cells that give rise to trophoblast giant cells and to the most placental lineages can be derived from the trophectoderm. *Tead2* transcripts are present in both cell lineages at approximately equal levels, and the expression of *Tead2* is stimulated upon differentiation into embryoid bodies. In contrast, *Dkk11* expression is low in ES cells and is further repressed upon differentiation of ES cells into embryoid bodies. However, trophoblast stem cells, which can form most extraembryonic tissues (Tanaka *et al.*, 1998), contain 57-fold more *Dkk11* mRNA than ES cells (Kohn *et al.*, unpublished data).

In postimplantation mouse embryos, *Dkk11* has been detected in the dorsal root ganglia of the developing spinal cord, in the cartilage primordium of the nasal septum, and in the developing eye. In adult animals, however, *Dkk11* mRNA is found almost exclusively in the testes, where *Dkk11*

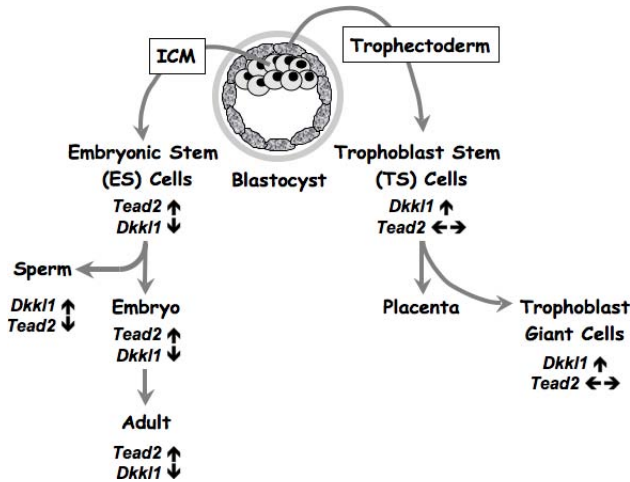

Fig. 3. Differential expression of *Tead2* and *Dkk11* mark divergent pathways to embryonic and placental tissues. The blastocyst is composed of two cell types: an outer layer of trophodermal cells and the inner cell mass (ICM). The trophoderm will form most of the extraembryonic tissues and the placenta. Trophoblast stem (TS) cells can be derived from the trophoderm cells that overlie the ICM. The ICM gives rise to the embryo proper. Embryonic stem (ES) cells can be derived from the ICM. Northern blotting hybridization, RT-PCR, and EST database analyses reveal that the trophoderm and its derivatives strongly express *Dkk11* (↑), whereas *Tead2* expression remains unchanged (↔). In contrast, the ICM and its derivatives strongly express *Tead2* (↑) and suppress expression of *Dkk11* (↓). One notable exception is in the male germ cells: developing spermatocytes strongly express *Dkk11* in the absence of *Tead2* expression, and *Dkk11* is eventually localized to the acrosome of mature sperm.

expression is exceptionally strong (Kaneko and DePamphilis, 2000; Kaneko *et al.*, 2004; Krupnik *et al.*, 1999). *In situ* hybridization of mouse testes shows that *Dkk11* is expressed specifically in developing spermatocytes, but not in spermatogonia. Expressed sequence tags (ESTs) for *Dkk11* confirm these results; they are found in spermatocytes, placenta, and in neural tissues including the eye and parts of the brain. While most tissues and cell lines express *Tead2* but not *Dkk11* (including TM3, derived from Leydig cells; and TM4, derived from Sertoli cells), lymphocytic cell lines express *Dkk11* but not *Tead2* (Kaneko *et al.*, 2004). It appears that after implantation, as cell lineages differentiate, most (perhaps all) cells express one of the two genes, but not both. Thus, *Dkk11* and *Tead2* become differentially expressed during development from ICM to adult.

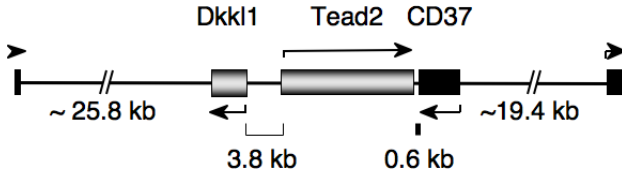

Fig. 4. The mouse *Dkk1/Tead2* locus. The mRNA start sites for the *Dkk1* and *Tead2* genes are only 3.8 kilobases apart, and the genes are transcribed in opposite directions, making this an unusual genomic locus. The same gene cassette containing *Dkk1*, *Tead2*, and *CD37* is also found in other eutherian mammals, but homologs to *Dkk1* have not been found in lower eukaryotes. In mouse embryos and adults, *Dkk1* and *Tead2* are differentially regulated: where one gene is expressed, the other is expressed only at basal levels, if at all.

Regulation of *Dkk1* and *Tead2* Gene Expression

Closely linked genes are common throughout mammalian genomes, but most closely linked genes are coordinately expressed: they are expressed or repressed together (Trinklein *et al.*, 2004) (Fig. 4). The *Dkk1/Tead2* locus provides a unique paradigm for the regulation of gene expression during mammalian development (Kaneko *et al.*, 2004). The differential expression of these two closely linked genes cannot be explained by the presence of insulator elements, because the intergenic sequence between *Dkk1* and *Tead2* does not contain insulator activity (Kaneko *et al.*, unpublished data). Cell lines that do not express *Dkk1* can nevertheless utilize the *Dkk1* promoter region to drive a reporter gene during transient transfection assays, suggesting that lack of *Dkk1* expression in most cells is likely not due to the absence of specific transcription factors (Kaneko and DePamphilis, 2000).

Promoters for both genes resemble prototypical housekeeping gene promoters, and the transcription start sites each lie within a CpG island, suggesting that DNA methylation — which begins in earnest after blastocyst formation — may determine which of the two genes is active. Furthermore, methylation of the *Dkk1/Tead2* promoters is inversely correlated with its promoter activity in established cell lines. However, in ES cells, splenocytes (cells from spleen enriched in lymphocytes), and other tissues (lung, uterus, liver), both promoters remain unmethylated, regardless of the expression status of their neighboring genes (Kaneko *et al.*, 2004). In fact, when ES cells are induced to differentiate in culture into embryoid bodies, *Dkk1* is suppressed without concomitant promoter methylation, suggesting that promoter methylation is not a prerequisite for *Dkk1* downregulation. This

Dkk11 downregulation in embryoid bodies is, however, accompanied by an increase in methylation of CpGs bordering its promoter.

Finally, recent preliminary results suggest that one potential importance for CpG methylation in the *Dkk11/Tead2* locus is to suppress transcripts originating from aberrant secondary promoters, which exist within the second intron of *Dkk11* and the first intron of *Tead2*. Thus, DNA methylation can restrict, but does not regulate, differential expression of these genes during mouse development. Nevertheless, as seen with cultured cells, chromatin repression induced by DNA methylation can prevent *Dkk11* expression, and presumably does so in tissues where *Dkk11* is methylated (Kaneko *et al.*, 2004).

Dkk11 and Spermatogenesis

To further elucidate the role of Dkk11, we examined the cellular location of *Dkk11* mRNA and protein in the testis of adult mice, the one site where sufficient Dkk11 protein could be detected with the available antibodies to allow accurate histochemical analysis (Kaneko and DePamphilis, 2000; Kohn *et al.*, 2005). In testes, *Dkk11* mRNA first appears in spermatocytes; likewise, Dkk11 protein first accumulates in zygotene spermatocytes as they transit to pachytene spermatocytes in stage XII seminiferous tubules (Fig. 5). As the spermatocytes progress through spermiation, Dkk11 associates with the nascent acrosome, the structure at the apex of mouse sperm that plays a vital role in fertilization by releasing proteases and hydrolases (Kim and Gerton, 2003). Immunofluorescence confirmed that Dkk11 colocalizes with other known acrosomal proteins. These results identified Dkk11 as a protein involved in acrosome formation during mammalian spermatogenesis.

The presence of Dkk11 in mature sperm demonstrates that at least some pool of Dkk11 is not secreted from developing sperm (Kohn *et al.*, 2005), despite the presence of an N-terminal signal peptide and the fact that other Dkk proteins, including HsDKKL1, have been shown to be secreted under at least some conditions (Krupnik *et al.*, 1999). Western immunoblotting and treatment with a glycosidase revealed that Dkk11 isolated from mouse testes is N-glycosylated, but that Dkk11 protein in mature sperm isolated from the cauda epididymides is not (Kohn *et al.*, 2005). Instead,

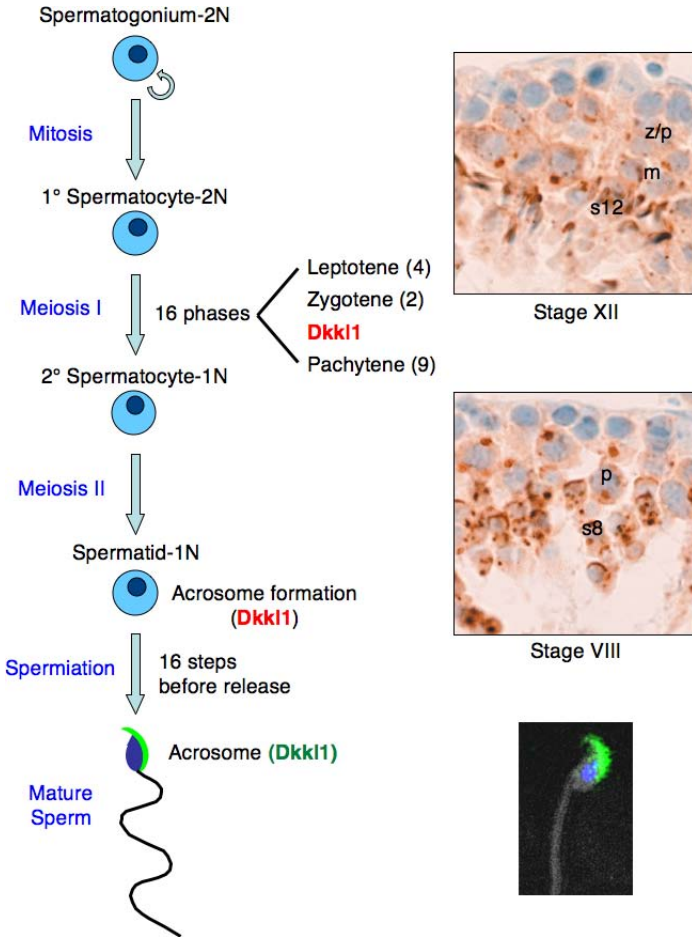

Fig. 5. Localization of Dkk1 protein in spermatocytes and mature sperm. The events in spermatogenesis are diagrammed on the left. The diploid spermatogonium divides mitotically to produce diploid primary spermatocytes. The primary spermatocytes proceed through meiosis I, which has 16 identifiable phases in the mouse seminiferous tubules, including 4 leptotene, 2 zygotene, and 9 pachytene. Following meiosis I, the secondary spermatocytes proceed rapidly through the second meiotic division, producing spermatids. Spermiation (the maturation of spermatids) has 16 steps prior to the release of the spermatids into the lumen of the tubule. Formation of the acrosome is considered to begin during spermiation. Stage XII tubules reveal that Dkk1 protein is first detected at the zygotene to pachytene spermatocyte (z/p) transition; meiotic-phase or secondary spermatocytes (m) and step 12 spermatids (s12) are also visible at this stage. In stage VIII tubules, Dkk1 is clearly accumulating in pachytene spermatocytes; and in step 8 spermatids (s8), is localized to a crescent-shaped structure that looks like the nascent acrosome. Finally, in mature sperm, Dkk1 localizes to the acrosomal region by immunofluorescence (green), with DNA indicated in blue.

Dkk11 from the mature sperm has undergone an additional posttranslational modification: although it is no longer N-glycosylated, it migrates at a higher molecular weight than the deglycosylated testis form of Dkk11.

Amino acid sequence analysis of Dkk11 suggests the potential for both myristoylation and phosphorylation, and these remain likely possibilities for further modification. Notably, amino acid sequence analysis does not suggest the presence of a GPI anchor as an explanation for the retention of Dkk11 in the acrosome. In the developing spermatocytes, the signal peptide likely targets the protein to the acrosome, which is derived from the Golgi apparatus. This is not an uncommon finding, since several other acrosomal proteins also have apparent signal peptides, including proacrosin (Kashiwabara *et al.*, 1990), sp10/Acrv1 (acrosomal vesicle protein 1) (Reddi *et al.*, 1995), and porcine sp32 (Baba *et al.*, 1994).

Is Dkk11 involved in fertilization? Fixed sperm exhibit a Dkk11 immunofluorescence signal throughout the acrosome (Kohn *et al.*, 2005). In contrast, live sperm that have not undergone capacitation do not react with antibodies directed against Dkk11. However, following capacitation, live sperm do react with anti-Dkk11 antibodies; but instead of staining the entire acrosome, the strongest signal comes from the apical tip of the sperm, in addition to discrete patches of staining along what appears to be the edge of the acrosome (Kohn *et al.*, unpublished data). These results suggest that at least some of the Dkk11 migrates to the surface of the sperm during capacitation. In fact, preliminary studies have revealed that anti-Dkk11 serum inhibits sperm binding to eggs. Finally, in acrosome-reacted sperm, Dkk11 staining is found in a diffuse pattern around the sperm head, suggesting that Dkk11 may be part of the acrosomal matrix and disperses along with the acrosomal contents after induction of the acrosome reaction.

The similarity of the second cysteine-rich region of the Dkks, and Dkk11 in particular, to colipase presents an intriguing possibility. Colipase can interact with lipid micelles and is essential for lipid hydrolysis in the pancreas (van Tilbeurgh *et al.*, 1999). Although Dkk11 lacks the actual cysteines necessary to form disulfide bonds, these regions could potentially mediate its localization to and retention in the acrosome through association with some membrane protein. In fact, evidence suggests that in sperm, Dkk11 is associated with the acrosomal membrane, but is not an actual membrane protein (Kohn *et al.*, unpublished data).

What Is the Function of *Dkk1*?

The fact that *Dkk1* is unique to mammals and is selectively expressed during the formation of trophoblast stem cells strongly suggests that it plays a critical role in the formation or function of extraembryonic/placental tissues. Where and when *Dkk1* is required for mammalian development will ultimately be understood by appropriate genetic analyses. In fact, chimeric mice have been generated containing a conditional “knock-out” of the *Dkk1* gene. In addition, siRNA can be used to silence the *Dkk1* gene during preimplantation development and trophoblast stem cell differentiation. Alternatively, retrovirus expression vectors can be used to constitutively express *Dkk1* under the same conditions. Nevertheless, several hypotheses are suggested by the available information.

Since HsDKK3 suppresses cell motility when overexpressed in tumor cell lines (Hoang *et al.*, 2004), *Dkk1* may suppress motility in developing spermatids, thus preventing their premature migration into the seminiferous tubule lumen and spermiation. Since HsDKK1 induces endocytosis upon binding to the LRP receptor (Mao *et al.*, 2002), *Dkk1* may induce budding of the Golgi complex driving acrosome formation. Since HsDKK3 is also an effector of Wnt signaling (Caricasole *et al.*, 2003), and Wnt signaling has clear roles in axon guidance (reviewed in Zou, 2004), *Dkk1* may have a role in the guidance of sperm through either the seminiferous tubules or the epididymis, or during fertilization.

Dkk1 may play a role in penetration through the zona pellucida from the outside by sperm, and from the inside by the trophectoderm. In this role, *Dkk1* would facilitate implantation by facilitating trophectodermal cells in degrading (“hatching” from) the zona pellucida (“egg shell”) so that the embryo can implant into the uterine endometrium. Thus, trophoblast giant cells, which upregulate *Dkk1*, produce proteases that allow invasion into the deciduum surrounding implanted embryos. Perhaps *Dkk1* facilitates the formation of exocytotic vesicles within the trophoblast giant cells that contain these enzymes, akin to the acrosome containing proteases.

Dkk1 may be involved in cell guidance. Since all the cell types that express *Dkk1* are migratory, this is a plausible role for a “secreted” signaling molecule. Alternatively, instead of being a functional component of the acrosome, *Dkk1* may be involved in trafficking and may thus be responsible for acrosome assembly in spermatocytes; its appearance on the

sperm surface may be a side-effect of its presence in the acrosome. This possibility is suggested by the presence of Dkk1 protein in pachytene spermatocytes, well before acrosome formation from Golgi vesicles is believed to commence (Yoshinaga and Toshimori, 2003).

References

- Baba, T., Niida, Y., Michikawa, Y., Kashiwabara, S., Kodaira, K., Takenaka, M., Kohno, N., Gerton, G. L., and Arai, Y. (1994). An acrosomal protein, sp32, in mammalian sperm is a binding protein specific for two proacrosins and an acrosin intermediate. *J Biol Chem* **269**, 10133–10140.
- Bafico, A., Liu, G., Goldin, L., Harris, V., and Aaronson, S. A. (2004). An autocrine mechanism for constitutive Wnt pathway activation in human cancer cells. *Cancer Cell* **6**, 497–506.
- Caricasole, A., Ferraro, T., Iacovelli, L., Barletta, E., Caruso, A., Melchiorri, D., Terstappen, G. C., and Nicoletti, F. (2003). Functional characterization of WNT7A signaling in PC12 cells: interaction with a FZD5 x LRP6 receptor complex and modulation by Dickkopf proteins. *J Biol Chem* **278**, 37024–37031.
- Davidson, G., Mao, B., del Barco Barrantes, I., and Niehrs, C. (2002). Kremen proteins interact with Dickkopf1 to regulate anteroposterior CNS patterning. *Development* **129**, 5587–5596.
- Dominguez, I., and Green, J. B. (2001). Missing links in GSK3 regulation. *Dev Biol* **235**, 303–313.
- Glinka, A., Wu, W., Delius, H., Monaghan, A. P., Blumenstock, C., and Niehrs, C. (1998). Dickkopf-1 is a member of a new family of secreted proteins and functions in head induction. *Nature* **391**, 357–362.
- Hoang, B. H., Kubo, T., Healey, J. H., Yang, R., Nathan, S. S., Kolb, E. A., Mazza, B., Meyers, P. A., and Gorlick, R. (2004). Dickkopf 3 inhibits invasion and motility of Saos-2 osteosarcoma cells by modulating the Wnt-beta-catenin pathway. *Cancer Res* **64**, 2734–2739.
- Kaneko, K. J., Cullinan, E. B., Latham, K. E., and DePamphilis, M. L. (1997). Transcription factor mTEAD-2 is selectively expressed at the beginning of zygotic gene expression in the mouse. *Development* **124**, 1963–1973.
- Kaneko, K. J., and DePamphilis, M. L. (2000). Soggy, a spermatocyte-specific gene, lies 3.8 kb upstream of and antipodal to TEAD-2, a transcription factor expressed at the beginning of mouse development. *Nucleic Acids Res* **28**, 3982–3990.
- Kaneko, K. J., Rein, T., Guo, Z. S., Latham, K., and DePamphilis, M. L. (2004). DNA methylation may restrict but does not determine differential gene expression at the Sgy/Tead2 locus during mouse development. *Mol Cell Biol* **24**, 1968–1982.
- Kashiwabara, S., Baba, T., Takada, M., Watanabe, K., Yano, Y., and Arai, Y. (1990). Primary structure of mouse proacrosin deduced from the cDNA sequence and its gene expression during spermatogenesis. *J Biochem (Tokyo)* **108**, 785–791.
- Katoh, Y., and Katoh, M. (2005). Comparative genomics on DKK2 and DKK4 orthologs. *Int J Mol Med* **16**, 477–481.

- Kemp, C., Willems, E., Abdo, S., Lambiv, L., and Leyns, L. (2005). Expression of all Wnt genes and their secreted antagonists during mouse blastocyst and postimplantation development. *Dev Dyn* **233**, 1064–1075.
- Kim, K. S., and Gerton, G. L. (2003). Differential release of soluble and matrix components: evidence for intermediate states of secretion during spontaneous acrosomal exocytosis in mouse sperm. *Dev Biol* **264**, 141–152.
- Kohn, M. J., Kaneko, K. J., and DePamphilis, M. L. (2005). DkkL1 (Soggy), a Dickkopf family member, localizes to the acrosome during mammalian spermatogenesis. *Mol Reprod Dev* **71**, 516–522.
- Krupnik, V. E., Sharp, J. D., Jiang, C., Robison, K., Chickering, T. W., Amaravadi, L., Brown, D. E., Guyot, D., Mays, G., Leiby, K., et al. (1999). Functional and structural diversity of the human Dickkopf gene family. *Gene* **238**, 301–313.
- Kurose, K., Sakaguchi, M., Nasu, Y., Ebara, S., Kaku, H., Kariyama, R., Arai, Y., Miyazaki, M., Tsushima, T., Namba, M., et al. (2004). Decreased expression of REIC/Dkk-3 in human renal clear cell carcinoma. *J Urol* **171**, 1314–1318.
- Li, L., Mao, J., Sun, L., Liu, W., and Wu, D. (2002). Second cysteine-rich domain of Dickkopf-2 activates canonical Wnt signaling pathway via LRP-6 independently of dishevelled. *J Biol Chem* **277**, 5977–5981.
- Li, X., Liu, P., Liu, W., Maye, P., Zhang, J., Zhang, Y., Hurley, M., Guo, C., Boskey, A., Sun, L., et al. (2005). Dkk2 has a role in terminal osteoblast differentiation and mineralized matrix formation. *Nat Genet* **37**, 945–952.
- Mao, B., Wu, W., Davidson, G., Marhold, J., Li, M., Mechler, B. M., Delius, H., Hoppe, D., Stannek, P., Walter, C., et al. (2002). Kremen proteins are Dickkopf receptors that regulate Wnt/beta-catenin signalling. *Nature* **417**, 664–667.
- Martinez-Salas, E., Linney, E., Hassell, J., and DePamphilis, M. L. (1989). The need for enhancers in gene expression first appears during mouse development with formation of a zygotic nucleus. *Genes Dev* **3**, 1493–1506.
- Marvin, M. J., Di Rocco, G., Gardiner, A., Bush, S. M., and Lassar, A. B. (2001). Inhibition of Wnt activity induces heart formation from posterior mesoderm. *Genes Dev* **15**, 316–327.
- Melin, F., Miranda, M., Montreau, N., DePamphilis, M. L., and Blangy, D. (1993). Transcription enhancer factor-1 (TEF-1) DNA binding sites can specifically enhance gene expression at the beginning of mouse development. *EMBO J* **12**, 4657–4666.
- Miller, J. R. (2002). The Wnts. *Genome Biol* **3**, REVIEWS3001.
- Nelson, W. J., and Nusse, R. (2004). Convergence of Wnt, beta-catenin, and cadherin pathways. *Science* **303**, 1483–1487.
- Reddi, P. P., Naaby-Hansen, S., Aguolnik, I., Tsai, J. Y., Silver, L. M., Flickinger, C. J., and Herr, J. C. (1995). Complementary deoxyribonucleic acid cloning and characterization of mSP-10: the mouse homologue of human acrosomal protein SP-10. *Biol Reprod* **53**, 873–881.
- Schneider, V. A., and Mercola, M. (2001). Wnt antagonism initiates cardiogenesis in *Xenopus laevis*. *Genes Dev* **15**, 304–315.
- Stewart, C. L. (2000). Oct-4, scene 1: the drama of mouse development. *Nat Genet* **24**, 328–330.
- Tanaka, S., Kunath, T., Hadjantonakis, A. K., Nagy, A., and Rossant, J. (1998). Promotion of trophoblast stem cell proliferation by FGF4. *Science* **282**, 2072–2075.

- Trinklein, N. D., Aldred, S. F., Hartman, S. J., Schroeder, D. I., Otilar, R. P., and Myers, R. M. (2004). An abundance of bidirectional promoters in the human genome. *Genome Res* **14**, 62–66.
- van Tilbeurgh, H., Bezzine, S., Cambillau, C., Verger, R., and Carriere, F. (1999). Colipase: structure and interaction with pancreatic lipase. *Biochim Biophys Acta* **1441**, 173–184.
- Vassilev, A., Kaneko, K. J., Shu, H., Zhao, Y., and DePamphilis, M. L. (2001). TEAD/TEF transcription factors utilize the activation domain of YAP65, a Src/Yes-associated protein localized in the cytoplasm. *Genes Dev* **15**, 1229–1241.
- Wang, Q., and Latham, K. E. (2000). Translation of maternal messenger ribonucleic acids encoding transcription factors during genome activation in early mouse embryos. *Biol Reprod* **62**, 969–978.
- Wu, W., Glinka, A., Delius, H., and Niehrs, C. (2000). Mutual antagonism between dickkopf1 and dickkopf2 regulates Wnt/beta-catenin signalling. *Curr Biol* **10**, 1611–1614.
- Yoshinaga, K., and Toshimori, K. (2003). Organization and modifications of sperm acrosomal molecules during spermatogenesis and epididymal maturation. *Microsc Res Tech* **61**, 39–45.
- Zou, Y. (2004). Wnt signaling in axon guidance. *Trends Neurosci* **27**, 528–532.

This page intentionally left blank

CHAPTER 9

ANTISENSE TRANSCRIPTION IN DEVELOPING MALE GERM CELLS

Wai-Yee Chan, Shao-Ming Wu, Lisa Rusczyk, Tin-Lap Lee,
and Owen M. Rennert

*Laboratory of Clinical Genomics,
National Institute of Child Health and Human Development,
National Institutes of Health,
Bethesda, MD 20892*

A number of processes in spermatogenesis, such as genomic imprinting and translation repression, have been implicated in the phenomenon of naturally occurring antisense transcripts (NATs). To our knowledge, however, a systematic search for antisense transcripts in spermatogenic cells has not been reported previously. Serial analysis of gene expression (SAGE) mapping of the transcriptome of germ cells at different stages of spermatogenesis revealed that a significant percentage (~31%) of differentially expressed genes is associated with antisense transcripts. Nucleotide sequence analysis of the orientation-specific RT-PCR products of 19 genes, as well as cloned antisense transcripts, demonstrated that antisense transcripts may arise through a spectrum of mechanisms: transcription of sense mRNA in the cytoplasm, transcription of the opposite strand of the sense gene locus, transcription of a pseudogene, and transcription of neighboring genes and the intergenic sequence. The level of expression of the sense transcript is always significantly higher ($p < 0.001$) than that of the antisense transcript. This differential expression of overlapping sense and antisense transcripts (SATs) in whole testes is similar to that observed in more differentiated germ cells, such as spermatocytes and spermatids. Analysis of stage-specific genes revealed that the SATs of some genes are expressed at different stages of spermatogenesis. This study establishes the prominence of antisense transcripts in male germ cells, and demonstrates the various mechanisms by which they arise. These observations show that further study of antisense transcriptions and their biological implication during spermatogenesis and development is warranted.

Keywords: Antisense transcripts; spermatogonium; spermatocyte; spermatid; pseudogene.

Corresponding author: Wai-Yee Chan; e-mail: chanwy@mail.nih.gov

Introduction

Although for many years antisense transcription has been known to occur in prokaryotes (Wagner and Simons, 1994; Simons, 1988), the widespread occurrence of natural antisense transcripts (NATs) in humans and mice has been appreciated only recently. When Shoemaker *et al.* (2001) attempted to validate the 78 486 annotated exons of the human genome using microarrays, they spotted the reverse-complement probes near the regular probes as negative controls. Using two sources of mRNA, they observed hybridization to $\sim 5\%$ of the control probes in possibly the first indication of the widespread occurrence of antisense transcription in the human genome.

The first reports demonstrating the prevalence of antisense transcriptions in humans and mice were published in 2002 (Fahey *et al.*, 2002; Lehner *et al.*, 2002; Shendure and Church, 2002). By comparing transcripts in the National Center for Biotechnology Information Reference Sequence (RefSeq) database (after excluding sequences that contain repeats) with a compilation of vertebrate mRNAs extracted from the European Molecular Biology Laboratory (EMBL) database, Lehner *et al.* (2002) identified 87 human genes that give rise to overlapping sense–antisense transcript (SAT) pairs transcribed from the same locus (*cis*) and 80 genes that give rise to NATs transcribed from different chromosomal locations (*trans*). At that time, the authors predicted that 2% of the 12 897 human mRNAs known would have antisense partners. Fahey *et al.* (2002), however, by searching through 11 015 protein-coding transcripts in RefSeq, identified 56 pairs of SATs, 45 of which were common to the list generated by Lehner *et al.* (2002). Shendure and Church (2002), using free and publicly available bioinformatic tools — MEGABLAST (Advanced Biomedical Computing Center, National Cancer Institute, Frederick, MD) and SIM4 (Department of Computer Science and Engineering, Pennsylvania State University, University Park, PA) — queried high-quality, directionally cloned expressed sequence tag (EST) libraries and mRNAs to identify 144 and 73 overlapping transcriptional units in the human and mouse genomes, respectively. The presence of antisense transcription in 33 of 39 of these units was experimentally confirmed.

Yelin *et al.* (2003), in applying computational analysis to the draft human genome sequence and human ESTs that span introns, identified 61 048 clusters that contained overlapping sequences representing a gene or a partial

gene. Sense–antisense pairs were contained in 2667 of the clusters. Further analysis of 264 of the clusters using a microarray that contained complementary oligonucleotide probes confirmed the presence of antisense transcripts in 112 cases. This finding led the authors to conclude that the human genome contains >1600 sense–antisense gene pairs or 3200 genes, roughly 8% of the estimated number of human genes. They found that most of the pairs of EST-derived NATs identified by Shendure and Church (2002) were artifacts. Another computational endeavor utilizing the FANTOM2 mouse cDNA set of 60 770 clones, public mRNA data, and the mouse genome sequence data identified 2481 *cis*-NATs, suggesting that ~15% of the mouse genes form SAT pairs (Kiyosawa *et al.*, 2003). Yelin *et al.* (2003) also identified 899 pairs of nonoverlapping bidirectional transcripts (*trans*-NAT).

Using the NCBI human and mouse genome assemblies, Veeramachaneni *et al.* (2004) identified 774 pairs of overlapping genes among 34 604 annotated genes in the human genome and 578 pairs of overlapping genes among 33 936 annotated genes in the mouse genome. Only annotated genomic sequence genes were analyzed, and no ESTs were included in the study. A more recent study of the human genome utilizing sequences in the UniGene database showed that 22% (5880) of the human transcription clusters form SAT pairs (Chen *et al.*, 2004). The presence of antisense transcripts was experimentally confirmed in 92% of the cases for a subset of the SAT pairs. The authors also showed that 2920 UniGene clusters form nonoverlapping bidirectional transcript pairs. These studies are biased towards discovering antisense transcripts that overlap with at least one exon of the sense transcript. A more recent study identified antisense and sense pairs of overlapping intronic transcripts in prostate cancer samples (Reis *et al.*, 2004), and corroborated previous findings of antisense intronic noncoding transcripts of human chromosomes 21 and 22 (Rinn *et al.*, 2003; Kampa *et al.*, 2004).

The application of serial analysis of gene expression (SAGE) provides another dimension in the search for antisense transcripts. The specific advantage of SAGE is that directionally reliable tags are generated from well-defined restriction sites at the 3' end of each transcript. Mapping SAGE tags to the reverse complement of known mRNAs allows the identification of antisense transcripts. Analysis of unique experimental tags from 260 published SAGE libraries revealed transcripts expressed from both strands

of adjacent, oppositely oriented transcription units as well as from overlapping transcripts of *trans*-encoded unique genes (Quere *et al.*, 2004). Another study, using the LongSAGE dataset of 41 718 unique tags, identified 1260 potential antisense genes (Wahl *et al.*, 2005). A method dedicated to the direct identification of overlapping mRNAs was recently developed (Rosok and Sioud, 2004; Rosok and Sioud, 2005) that selects double-stranded cDNA as a result of hybridization between first-stranded cDNAs from the same cell type. Different from the SAGE approach, this method allows identification of both polyadenylated and nonadenylated transcripts.

Potential Function of Antisense Transcripts

Our understanding of the biological roles of antisense transcripts is in its infancy and, in the majority of them, their significance is currently unknown. Only a few NATs have been studied in detail and assigned a function (Fig. 1). A number of antisense transcripts have been shown to encode novel proteins (Knee *et al.*, 1997; Hastings *et al.*, 2000; Spiess *et al.*, 2003; Harper *et al.*, 2004) (Fig. 1A). Perturbation of antisense RNA expression can alter the expression of sense mRNAs and vice versa, suggesting that antisense transcription contributes to the control of transcriptional outputs (Shi *et al.*, 2000; Cheng *et al.*, 2002; Rosok and Sioud, 2004; RIKEN Genome Exploration Research Group *et al.*, 2005) (Fig. 1B). They can serve as either positive effectors (Tasheva and Roufa, 1995; Landers *et al.*, 2005) or negative effectors (Nepveu and Marcu, 1986; Khochbin *et al.*, 1992) of the transcription of the sense transcript.

Antisense transcripts have been implicated in autosomal imprinting and X-chromosome inactivation (Fig. 1C). Many SATs show reciprocal imprinting, leading to the suggestion that there may be a hidden unified mechanism between antisense transcription and imprinting (Chamberlain and Brannan, 2001; Ogawa and Lee, 2002; Yamasaki *et al.*, 2003; Shibata and Lee, 2004; Morison *et al.*, 2005). An example of this mechanism is the observation that the expression of the noncoding, paternally imprinted *Air* RNA, which overlaps with the *Igf2r* promoter, is correlated with repression of expression of three imprinted, maternally expressed protein-coding genes: *Igf2r/Slc22a2/slc22a3* (Sleutels *et al.*, 2002). Competitive transcription interference has been shown in a number of cases, in which the

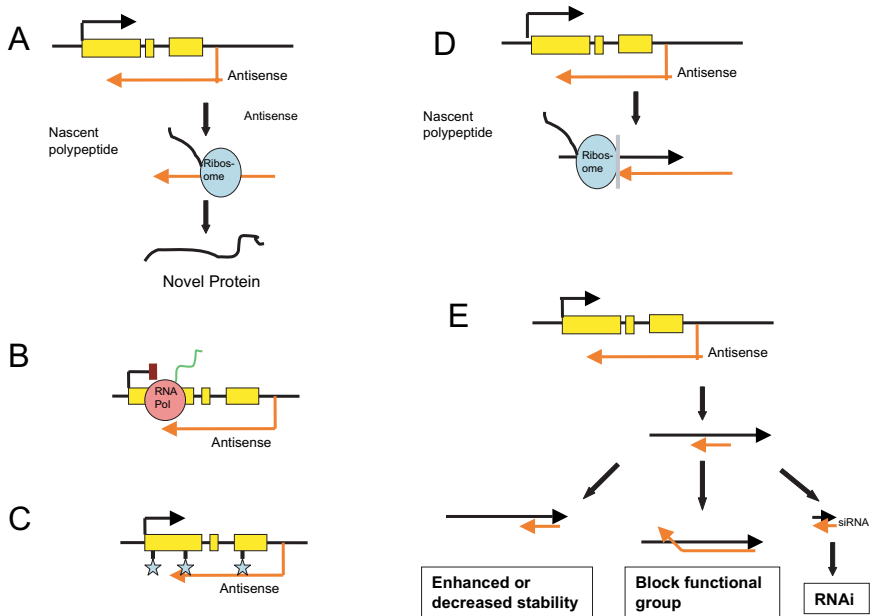

Fig. 1. Putative function of antisense transcripts. Black arrow represents sense transcript, and orange arrow represents antisense transcript. **A.** Antisense transcript encodes a novel protein. **B.** Antisense transcript blocks sense gene transcription. **C.** Antisense transcript affects the imprinting of the sense gene. Blue stars represent methyl group. **D.** Antisense transcript blocks the translation of the sense transcript mRNA. **E.** Antisense transcript forms an RNA duplex with the sense transcript. This enhances or decreases the stability of the sense mRNA, blocks the functional group on the sense mRNA and affects its binding with other factors, or results in RNA interference subsequent to the formation of siRNA.

expression of the SATs is inversely correlated (Silverman *et al.*, 1992; Farrell and Lukens, 1995; Wutz *et al.*, 1997). Antisense RNA has been proposed to be involved in coordinating cardiac myosin heavy-chain gene switching (Haddad *et al.*, 2003).

Antisense transcripts can also function posttranscriptionally (Robb *et al.*, 2004) (Figs. 1D and 1E). An example is the regulation of BCMA (B-cell maturation) by its antisense transcript, the overexpression of which results in a large decrease in the amount of BCMA proteins produced with no change in BCMA RNA level (Hatzoglou *et al.*, 2002). It has been suggested that many *cis*-encoded NATs exert regulation by preferentially targeting 3' UTRs of mRNAs (Sun *et al.*, 2005), as in the case of induction of

site-specific cleavage of thymidylate synthase mRNA by its antisense transcript (Chu and Dolnick, 2002).

Formation of double-stranded (ds) RNA by the SATs has been demonstrated for human $\alpha 3$ and $\alpha 5$ nicotinic receptor subunit mRNAs that overlap at their 3' end (Solda *et al.*, 2005). RNA–RNA duplexes can regulate gene expression at multiple levels, including transcription, mRNA processing, splicing, stability, transport, and translation (Vanhee-Brossollet and Vaquero, 1998; Lavorgna *et al.*, 2004). dsRNA formation can mask the mRNA and can affect any step in gene expression involving protein–RNA interactions, as exemplified by the inhibition of alternative splicing of the ErbA α mRNA induced by the antisense Rev-ErbA α transcript (Munroe and Lazar, 1991; Lipman, 1997; Hastings *et al.*, 2000). RNA duplex formation may also lead to the activation of dsRNA-dependent pathways, including RNA editing by adenosine deaminase and RNA interference (RNAi)-dependent gene silencing (Neeman *et al.*, 2005), both of which were shown in *Drosophila* (Aravin *et al.*, 2001; Peters *et al.*, 2003). A recent study, however, disputed the involvement of RNAi in natural antisense-mediated regulation of gene expression in mammals (Faghihi and Wahlestedt, 2006).

Aberrant sense–antisense expression has been implicated in a number of diseases. Transcription of antisense RNA has been shown to lead to gene silencing and methylation in a case of α -thalassemia (Tufarelli *et al.*, 2003). Upregulation of apolipoprotein E antisense transcript (ApoES1) has been found in mice after spinal cord injury (Seitz *et al.*, 2005). The expression of the antisense transcript of hypoxia-inducible factor 1 alpha has been shown to be upregulated in common human cancers (Thrash-Bingham and Tartof, 1999; Rossignol *et al.*, 2002). Similarly, changes in antisense transcription has been shown in B-cell lymphomas (Laabi *et al.*, 1994), endometriosis (Mihalich *et al.*, 2003), spinocerebellar ataxia type 8 (Nemes *et al.*, 2000), Wilms' tumor (Vu *et al.*, 2003), and breast cancer (Cayre *et al.*, 2003).

Antisense Transcription in Germ Cells

Repression of translation is one of the characteristic features of mammalian spermatogenesis (Kleene, 2001). Meiotic and haploid spermatogenic cells exhibit atypical patterns of gene expression, in which alternative splicing often gives rise to spermatogenic cell-specific transcripts (Cataldo *et al.*,

1999). There is also global inhibition of the initiation of mRNA translation in pachytene spermatocytes and round spermatids (Kleene, 2001; Kleene, 2003). Little is known about the mechanisms of translational regulation in spermatogenic cells. Antisense transcription offers possible explanations for some of these mechanisms.

A systematic search for antisense transcripts during spermatogenesis has only recently been documented. Previous efforts to delineate mouse spermatogenic cell gene expression either only focused on a few genes or used the microarray platform, which does not permit detection of antisense transcripts (Wang *et al.*, 2001; Sha *et al.*, 2002; Tanaka *et al.*, 2002; Anway *et al.*, 2003; Pang *et al.*, 2003; Schultz *et al.*, 2003; Yu *et al.*, 2003; Almstrup *et al.*, 2004; Guo *et al.*, 2004). The lack of a reliable mouse spermatogenic cell Unigene/EST database compounded the problem. An antisense transcript, SPEER-2, was observed in late pachytene spermatocytes and early round spermatids in the mouse (Rockett *et al.*, 2001). Recent SAGE profiling of genes expressed in mouse spermatogenic cells — including type A spermatogonia, pachytene spermatocytes, and round spermatids — allowed an examination of antisense transcription during spermatogenic cell development (Wu *et al.*, 2004). Of 64 genes expressed in mouse germ cells, 19 (~31%) were demonstrated to have antisense transcripts (Chan *et al.*, 2006d). Some of these genes have more than one NAT (Table 1).

Studies of the Expression of Antisense Transcripts

The sense transcripts of the 19 genes that have antisense transcripts always exhibit significantly higher ($p < 0.001$) expression than the antisense transcripts in testis (Chan *et al.*, 2006d). Coexpression of the SATs in the same tissue or cell suggests potential interaction between the SATs similar to that described for *Nphs1* (Ihalmo *et al.*, 2004; Solda *et al.*, 2005). Different from that observed in testis, the expression of the SATs in nontesticular tissues is variable. Studies of nine selected genes demonstrated differential expression of the SATs of some genes in different nontesticular tissues, implying tissue-specific regulation of antisense transcription (Chan *et al.*, 2006d). Similar observations have been reported for other genes (Nishida *et al.*, 2005; RIKEN Genome Exploration Research Group *et al.*, 2005), particularly imprinted genes (Li *et al.*, 2002; Yamasaki *et al.*, 2003; Lavorgna

Table 1. Genes with antisense transcripts. The chromosomal location of the genes is shown in the Chromosome column. Numbers in the SAT column indicate the number of SAT pairs identified for each gene.

Symbol	Gene name	Chromosome	SAT
<i>Ch10</i>	Heat shock 10 kDa protein 1 (chaperonin 10)	1	1
<i>Dnajb3</i>	<i>DnaJ</i> (<i>Hsp40</i>) homolog, subfamily B, member 3	1	1
<i>Gk-rs2</i>	Glucokinase activity, related sequence 2	5	2
<i>Pdc12</i>	Phosducin-like 2	5	3
<i>Ppp1cc</i>	Protein phosphatase 1, catalytic subunit, gamma isoform	5	1
<i>Sh3-Stam</i>	Associated molecule with the SH3 domain of STAM	6	1
<i>Ldh3c</i>	Lactate dehydrogenase 3, C chain, sperm-specific	7	3
<i>Uba52</i>	Ubiquitin A-52 residue ribosomal protein fusion product 1	8	1
<i>Adam5</i>	A disintegrin and metalloproteinase domain 5	8	2
<i>Sap17</i>	Sperm autoantigenic protein 17	9	1
<i>Fhl4</i>	Four and a half LIM domains 4	10	2
<i>Ubb</i>	Ubiquitin B	11	2
<i>Dbil5</i>	Diazepam-binding inhibitor-like 5	11	2
<i>Calm2</i>	Calmodulin 2	12	2
<i>Prm1</i>	Protamine 1	16	1
<i>Prm2</i>	Protamine 2	16	2
<i>Tsg1</i>	Testis-specific gene 1	17	1
<i>Tcte3</i>	T-complex-associated testis expressed 3	17	2
<i>Ppic</i>	Peptidylprolyl isomerase C	18	1

et al., 2004; Landers *et al.*, 2005). Therefore, antisense transcription is tissue-specific for some genes.

Stage-Specific Expression of Antisense Transcripts

Cell- or stage-specific expression of genes is common during spermatogenesis. For example, cell-specific alternative splicing of genes has been abundantly demonstrated in male germ cells (Chan *et al.*, 2006a). Stage-specific expression of antisense transcripts has also been observed. Excluding the rare transcripts and Unigenes with uncharacterized cDNAs, our studies showed that 41 genes have spermatogonia-specific antisense transcripts, 29 genes have spermatocyte-specific antisense transcripts, and 17 genes have spermatid-specific antisense transcripts (Chan *et al.*, 2006b). Thus, the regulation of antisense transcription is also dependent on the stage of development during spermatogenesis.

Structural Complexity of Antisense Transcripts Identified in Germ Cells

Based on the structure of antisense amplicons obtained by orientation-specific RT-PCR, three groups can be identified among the 19 genes studied (Fig. 2). Group 1 genes give rise to antisense amplicons, which are 100% complementary to their sense transcripts; group 2 genes give rise to partially homologous antisense amplicons; and group 3 genes have antisense amplicons derived from the pseudogenes (Chan *et al.*, 2006d).

Group 1 antisense transcripts

Members of this group include a disintegrin and metalloprotease domain 5 (*Adam5*); diazepam-binding inhibitor-like 5 (*Dbil5*); *DnaJ* (*Hsp40*) homolog, subfamily B, member 3 (*Dnajb3*); four and a half LIM domains 4 (*Fhl4*); glucokinase activity, related sequence 2 (*Gk-rs2*); phosphatidylinositol 3-kinase-related kinase 2 (*Pdcl2*); peptidylprolyl isomerase C (*Ppic*); γ isoform of protein phosphatase 1, catalytic subunit (*Ppp1cc*); protamine 2 (*Prm2*); sperm autoantigenic protein 17 (*Sap17*); associated molecule with the SH3 domain of STAM (*Sh3-Stam*); testis-specific gene 1 (*Tsg1*); sperm-specific lactate dehydrogenase 3, C chain (*Ldh3c*); and t-complex-associated testis expressed 3 (*Tcte3*).

The majority of the antisense amplicons of this group of genes include only one exon, with the exception of those of *Tcte3* and *Ldh3c*, which are

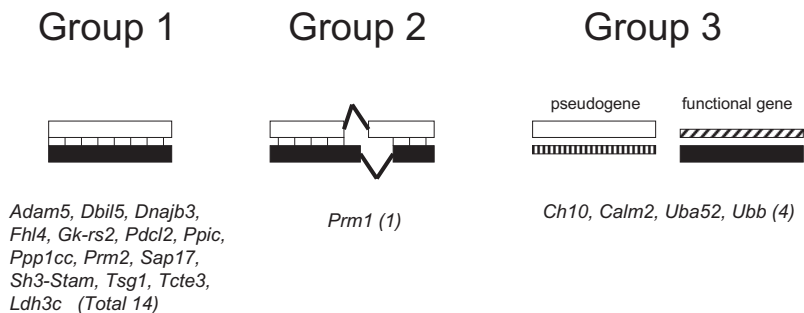

Fig. 2. Structural groups of antisense amplicons. ■ sense transcript; □ antisense transcript. Hedged bars represent untranscribed sequences. Homology is indicated by vertical lines. The number of genes in each group is shown.

composed of two and three spliced exons, respectively. Subsequent analyses showed that the antisense transcripts of *Tcte3* and *Ldh3c* are short (<300bp) and could not be extended beyond the exons identified in the antisense amplicons. Furthermore, attempts to identify genes the antisense amplicon of which contains more than one exon did not yield any result, indicating that the putative RNA-dependent RNA polymerase (RdRP) activity in mouse germ cells is gene-specific (Wu and Ruzsczyk, unpublished observations). Molecular cloning of the antisense transcripts of *Tcte3* yielded two similar transcripts of variable length, both lacking a poly(A) tail. Unlike the antisense amplicon identified by orientation-specific RT-PCR, neither of the *Tcte3* antisense transcripts cloned overlapped more than one exon, possibly due to the limitation of the 3' RACE approach, which selects transcripts with a poly(A) sequence at the 3' end. It is suggested that there may exist more than two species of antisense transcripts of *Tcte3*, some of which are not polyadenylated (Chan *et al.*, 2006d).

Total complementarity of the antisense amplicons to the spliced exons of the sense genes suggests that they are synthesized in the cytoplasm after the sense transcripts are processed. Similar observations have been made with antisense transcripts of cardiac troponin 1 (Podlowski *et al.*, 2002; Bartsch *et al.*, 2004), hemoglobin β (Volloch *et al.*, 1996; Bonafoux *et al.*, 2004), and rat urocortin (Shi *et al.*, 2000). It is postulated that these antisense transcripts are transcribed in the cytoplasm from the sense mRNA by RdRP activity (Volloch *et al.*, 1996; Bartsch *et al.*, 2004; Chen *et al.*, 2004). A cytoplasmic, microsomal-bound RdRP was reported to be partially purified from rabbit reticulocyte lysates in 1973 (Downey *et al.*, 1973); no subsequent purification of the enzyme protein has been reported. A murine retinoic acid-responsive gene *Aquarius* (*Aqr*) contained a RdRP motif (Sam *et al.*, 1998), again raising the possibility of the presence of RdRP in eukaryotic cells. The role of RdRP in generating antisense globin RNA has been questioned (Gudima and Taylor, 2001), and its presence in eukaryotes remains an unconfirmed observation.

Group 2 antisense transcripts

Protamine 1 (*Prm1*) is the sole member of this group. Its antisense transcript consists of more than one exon. Only part of the antisense amplicon is complementary to the exons in the sense transcript; part of it is complementary

to the intron between the two exons of the sense gene (Chan *et al.*, 2006d). It is apparently the product of posttranscription splicing of a larger antisense transcript, which is processed by a splicing mechanism similar to that of the sense transcripts (Mount, 1982). A number of antisense transcripts were previously reported to arise in a similar manner (Knee *et al.*, 1997; Hastings *et al.*, 2000; Nemes *et al.*, 2000; Li *et al.*, 2002; Vu *et al.*, 2003; Hernandez *et al.*, 2004; Robb *et al.*, 2004). We cloned three full-length alternatively spliced antisense transcripts of *Prm1*. The longest antisense transcript, in addition to its complementarity to *Prm1*, contained sequences that are complementary to a portion of *Prm2* and the intergenic sequence between the two genes (Chan *et al.*, 2006d). All three antisense transcripts contained the same open reading frame that encodes a putative polypeptide with casein kinase II phosphorylation and myristoylation sites.

Group 3 antisense transcripts

Group 3 genes have antisense amplicons complementary to pseudogenes. Four of these are calmodulin 2 (*Calm2*), heat shock 10 kDa protein 1 (chaperonin 10) (*Ch10*), ubiquitin A-52 residue ribosomal protein fusion product 1 (*Uba52*), and ubiquitin B (*Ubb*). These antisense amplicons display 88%–94% homology to their sense transcripts, but are 99% identical to their pseudogenes on chromosomes 12, 2, 11, and 2, respectively. These pseudogenes are present in the intron of actively transcribed genes (Chan *et al.*, 2006c). The *Uba52* pseudogene resides in the intron of chromobox homolog 1 (*Cbx1*); *Calm2* pseudogene is in the intron of protein kinase, cAMP-dependent, regulatory subunit beta 2 (*Prkar2b*); *Ch10* pseudogene is in the intron of *trans*-activating transcription factor 3 (*Sp3*); and *Ubb* pseudogene resides in the intron of cation channel, sperm associated 2 (*Catsper2*).

Apparently, these pseudogenes were retrotransposed and inserted into the intron of the host genes. The direction of transcription of the functional parent gene is opposite to that of the host gene. The expression patterns of the parent gene and host gene during spermatogenesis are comparable, with the exception of *Prkar2b* (which is only expressed in type A spermatogonia) and *Calm2* (which is mainly expressed in pachytene spermatocytes). The different temporal expressions of these two genes may imply no interaction between them. *Sp3*, the host gene of the *Ch10* pseudogene, is also only expressed in type A spermatogonia. Expression of *Cbx1*

falls with differentiation, while *Catsper2* is preferentially expressed in spermatocytes and spermatids (Chan and Wu, unpublished observations). For *Uba52*, *Ch10*, and *Calm2*, there is no evidence that the antisense strands of the pseudogene are transcribed, and the antisense amplicons identified may be derived from the spliced intron of the host genes.

Whether the pairing of the functional transcript and the pseudogene-containing intron affects the translation of the functional transcript or the processing of the host gene is unknown. Albeit rarely observed in somatic cells, pseudogene-derived antisense transcripts are not unique to germ cells. The antisense transcript of neural nitric oxide synthase (*nNOS*) was reported to be transcribed from a pseudogene (Korneev *et al.*, 1999). Judging from the proportion of antisense transcripts derived from pseudogenes and from the number of such genes identified in the mouse and human genomes (Zhang *et al.*, 2003; Zhang and Gerstein, 2004; Harrison *et al.*, 2005; Khelifi *et al.*, 2005), pseudogenes may be a rich source of antisense transcripts in germ cells.

Despite the fact that the antisense amplicon of *Uba52* is homologous to the pseudogene on chromosome 11, molecular cloning identified two groups of antisense transcripts, and neither were derived from the functional gene on chromosome 8 or the pseudogene on chromosome 11. One group of cloned antisense transcripts was derived from a putative pseudogene at the tip of the short arm of chromosome 4, and the other from the pseudogene on the long arm of chromosome 9. Both putative pseudogenes are 97%–98% homologous to *Uba52* mRNA, with no introns and a poly(A) stretch with 24 and 17 A's respectively. All antisense transcripts predict extra exons downstream from the 3' end of the pseudogene identified by the putative ancestral poly(A) tail. Computer-assisted translation of the chromosome 4-derived antisense transcript revealed an open reading frame of 393 bp with no recognizable protein motif. The chromosome 9-derived antisense transcripts have no open reading frame of appreciable size (Chan *et al.*, 2006d).

Identification of antisense transcripts derived from pseudogenes embedded in the intron of antiparallel genes suggest a novel function of noncoding introns. These introns serve as messengers, mediating the interaction between the antiparallel gene pair and giving an additional layer of complexity to the regulation of gene expression.

Conclusion

A significant percentage of differentially expressed genes in spermatogenic germ cells are associated with antisense transcripts. These transcripts arise through a wide spectrum of mechanisms during spermatogenesis: transcription of the sense mRNA in the cytoplasm, transcription of the opposite strand of the sense gene locus, transcription of a pseudogene, or transcription of neighboring genes and the intergenic sequence. Four of 19 genes examined have antisense transcripts derived from pseudogenes, indicating that pseudogenes are a rich source of antisense transcripts, particularly in male germ cells.

Antisense transcripts have been proposed to have functions in transcriptional and posttranscriptional regulation (Blin-Wakkach *et al.*, 2001; Lavorgna *et al.*, 2004), DNA methylation (Imamura *et al.*, 2004), genomic imprinting (Ogawa and Lee, 2002), and other genetic processes (Kiyosawa and Abe, 2002; Shendure and Church, 2002; Lavorgna *et al.*, 2004; Mattick, 2004). Thus, antisense transcription provides an additional layer of control in regulating gene expression. Antisense transcripts derived from pseudogenes embedded in the intron of antiparallel genes suggest a novel function for noncoding RNA and additional regulatory complexity of gene interaction. This observation further supports the role of introns as a resource of functional noncoding RNAs (Mattick and Makunin, 2006).

The majority of the 19 genes expressed at a higher level in more differentiated germ cells, which suggests the increasing importance of antisense transcripts in haploid differentiated cells during spermatogenesis. Although the cause of the apparent preferential use of antisense transcription in these germ cells compared with diploid spermatogonia is unknown, it is tempting to speculate that vigorous control of gene expression is necessary to ensure accuracy or to facilitate the biological processes that occur during spermatogenesis (e.g. genome-wide methylation–demethylation, genomic imprinting, monoallelic gene expression), particularly when biallelic expression is absent in haploid cells.

Spermatogenesis is the only genetic process in males that involves both mitosis and meiosis. Spermatogonial stem cells undergo self-renewal, asymmetric division, and premeiotic and postmeiotic differentiation to give rise to mature sperms. Genetic regulation of the germ cell is complex. The identification of antisense transcripts, particularly those derived from

intron-embedded pseudogenes, adds another dimension of complexity to gene regulation in spermatogenesis. Most studies of antisense transcription are still limited to a description of the phenomenon. More work is required to establish the role of antisense transcripts in regulating gene transcription and translation during spermatogenesis.

Acknowledgments

This research was supported by the Intramural Research Program of the National Institute of Child Health and Human Development, National Institutes of Health.

References

- Almstrup, K., Nielsen, J. E., Hansen, M. A., Tanaka, M., Skakkebaek, N. E., and Leffers, H. (2004). Analysis of cell-type-specific gene expression during mouse spermatogenesis. *Biol Reprod* **70**, 1751–1761.
- Anway, M. D., Ravindranath, N., Dym, D., and Griswold, M. D. (2003). Expression of testicular germ cell genes identified by differential display. *J Androl* **24**, 173–184.
- Aravin, A. A., Naumova, N. M., Tulin, A. V., Vagin, V. V., Rozovsky, Y. M., and Gvozdev, V. A. (2001). Double-stranded RNA-mediated silencing of genomic tandem repeats and transposable elements in the *D. melanogaster* germline. *Curr Biol* **11**, 1017–1027.
- Bartsch, H., Voigtsberger, S., Baumann, G., Morano, I., and Luther, H. P. (2004). Detection of a novel sense-antisense RNA-hybrid structure by RACE experiments on endogenous troponin 1 antisense RNA. *RNA* **10**, 1215–1224.
- Blin-Wakkach, C., Lezot, G., Ghouli-Mazgar, S., Hotton, D., Monteiro, S., Teillaud, C., Pibouin, L., Orestes-Cardoso, S., Papagerakis, P., Macdougall, M., et al. (2001). Endogenous Msx1 antisense transcript: in vivo and in vitro evidences, structure, and potential involvement in skeleton development in mammals. *Proc Natl Acad Sci U S A* **98**, 7336–7341.
- Bonafoux, B., Lejeune, M., Piquemal, D., Quere, R., Baudet, A., Assaf, L., Marti, J., Aguilar-Martinez, P., and Commes, T. (2004). Analysis of remnant reticulocyte mRNA reveals new genes and antisense transcripts expressed in the human erythroid lineage. *Haematologica* **89**, 1434–1438.
- Cataldo, L., Mastrangelo, M.-A., and Kleene, K. C. (1999). A quantitative sucrose gradient analysis of the distribution of 18 mRNA species in testes from adult mice. *Mol Hum Reprod* **5**, 206–213.
- Cayre, A., Rossignol, F., Clottes, E., and Penault-Llorca, F. (2003). aHIF but not HIF-1 α transcript is a poor prognostic marker in human breast cancer. *Breast Cancer Res* **5**(6), R223–R230. E-pub Sept 26.
- Chamberlain, S. J., and Brannan, C. I. (2001). The Prader-Willi syndrome imprinting center activates the paternally expressed murine *Ube3a* antisense transcript but represses paternal *Ube3a*. *Genomics* **73**, 316–322.

- Chan, W. Y., Lee, T. L., Wu, S. M., Rusczyk, L., Alba, D., Baxendale, V., and Rennert, O. M. (2006a). Transcriptome analyses of male germ cells with serial analysis of gene expression (SAGE). *Mol Cell Endocrinol* **250**, 8–19.
- Chan, W. Y., Lee, T. L., Wu, S. M., Rusczyk, L., Baxenda, V., and Rennert, O. M. (2006b). Expression of antisense transcripts in male germ cells. *Int Congr Hum Genet*, abstract (submitted).
- Chan, W. Y., Wu, S. M., Hovrath, L., Rusczyk, L., Mikhaylova, E., and Rennert, O. M. (2006c). Characterization of expressed anti-parallel transcription units in male germ cells. *Am Soc Hum Genet 56th Annu Meet*, abstract (submitted).
- Chan, W. Y., Wu, S. M., Rusczyk, L., Law, E., Lee, T. L., Baxendale, V., and Rennert, O. M. (2006d). The complexity of antisense transcription revealed by the study of developing male germ cells. *Genomics* **87**, 681–692.
- Chen, J., Sun, M., Kent, W. J., Huang, X., Xie, H., Wang, W., Zhou, G., Shi, R. Z., and Rowley, J. D. (2004). Over 20% of human transcripts might form sense-antisense pairs. *Nucleic Acids Res* **32**, 4812–4820.
- Cheng, C. H., Yew, D. T. W., Kwan, H. Y., Zhou, Q., Huang, Y., Liu, Y., Chan, W. Y., and Yao, X. (2002). An endogenous RNA transcript antisense to CNG α 1 cation channel mRNA. *Mol Biol Cell* **13**, 3693–3705.
- Chu, J., and Dolnick, B. (2002). Natural antisense (rTSA) RNA induces site-specific cleavage of thymidylate synthase mRNA. *Biochim Biophys Acta* **1587**, 183–193.
- Downey, K. M., Byrnes, J. J., Jurmark, B. S., and So, A. G. (1973). Reticulocyte RNA-dependent RNA polymerase. *Proc Natl Acad Sci U S A* **70**, 3400–3404.
- Faghihi, M. A., and Wahlestedt, C. (2006). RNA interference is not involved in natural antisense mediated regulation of gene expression in mammals. *Genome Res* **7**, R38.1–R38.9.
- Fahey, M. E., Moore, T. F., and Higgins, D. G. (2002). Overlapping antisense transcription in the human genome. *Comp Funct Genomics* **3**, 244–253.
- Farrell, C. M., and Lukens, L. N. (1995). Naturally occurring antisense transcripts are present in chick embryo chondrocytes simultaneously with the down-regulation of the α 1(I) collagen gene. *J Biol Chem* **270**, 3400–3408.
- Gudima, S. O., and Taylor, J. M. (2001). Search for antisense copies of beta-globin mRNA in anemic mouse spleen. *BMC Biochem* **2**, 3.
- Guo, R., Yu, Z., Guan, J., Ge, Y., Ma, J., Li, S., Wang, S., Xue, S., and Han, D. (2004). Stage-specific and tissue-specific expression characteristics of differentially expressed genes during mouse spermatogenesis. *Mol Reprod Dev* **67**, 264–272.
- Haddad, F., Bodell, P. W., Qin, A. X., Giger, J. M., and Baldwin, K. M. (2003). Role of antisense RNA in coordinating cardiac myosin heavy chain gene switching. *J Biol Chem* **278**, 37131–37138.
- Harper, R., Xu, C., Di, P., Chen, Y., Privalsky, M., and Wu, R. (2004). Identification of a novel *MAGE D2* antisense RNA transcript in human tissues. *Biochem Biophys Res Commun* **324**, 199–204.
- Harrison, P. M., Zheng, D., Zhang, Z., Carriero, N., and Gerstein, M. (2005). Transcribed processed pseudogenes in the human genome: an intermediate form of expressed retrosequence lacking protein-coding ability. *Nucleic Acids Res* **33**, 2374–2383.
- Hastings, M. L., Ingle, H. A., Lazar, M. A., and Munroe, S. H. (2000). Post-transcriptional regulation of thyroid hormone receptor expression by cis-acting sequences and a naturally occurring antisense RNA. *J Biol Chem* **275**, 11507–11513.

- Hatzoglou, A., Deshayes, F., Madry, C., Lapree, G., Castanas, E., and Tsapis, A. (2002). Natural antisense RNA inhibits the expression of BCMA, a tumour necrosis factor receptor homologue. *BMC Mol Biol* **3**, 4. E-pub April 18.
- Hernandez, A., Martinez, M. E., Croteau, W., and St. Germain, D. L. (2004). Complex organization and structure of sense and antisense transcripts expressed from the DIO3 gene imprinted locus. *Genomics* **83**, 413–424.
- Ihalmo, P., Rinta-Valkama, J., Mai, P., Astrom, E., Palmen, T., Pham, T. T., Floss, T., and Holthofer, H. (2004). Molecular cloning and characterization of an endogenous antisense transcript of Nphs1. *Genomics* **83**, 1134–1140.
- Imamura, T., Yamamoto, S., Ohgane, J., Hattori, N., Tanaka, S., and Shiota, K. (2004). Non-coding RNA directed DNA demethylation of *Sphk1* CpG island. *Biochem Biophys Res Commun* **322**, 593–600.
- Kampa, D., Cheng, J., Kapranov, P., Yamanaka, M., Brubaker, S., Cawley, S., Drenkow, J., Piccolboni, A., Bekiranov, S., Helt, G., et al. (2004). Novel RNAs identified from an in-depth analysis of the transcriptome of human chromosomes 21 and 22. *Genome Res* **14**, 331–342.
- Khelifi, A., Duret, L., and Mouchiroud, D. (2005). HOPPSIGEN: a database of human and mouse processed pseudogenes. *Nucleic Acids Res* **33**, D59–D66.
- Khochbin, S., Brocard, M. P., Grunwald, D., and Lawrence, J. J. (1992). Antisense RNA and p53 regulation in induced murine cell differentiation. *Ann N Y Acad Sci* **660**, 77–87.
- Kiyosawa, H., and Abe, K. (2002). Speculations on the role of natural antisense transcripts in mammalian X chromosome evolution. *Cytogenet Genome Res* **99**, 151–156.
- Kiyosawa, H., Yamanaka, I., Osato, N., Kondo, S., RIKEN GER Group and GSL Members, and Hayashizaki, Y. (2003). Antisense transcripts with FANTOM2 clone set and their implications for gene regulation. *Genome Res* **12**, 1324–1334.
- Kleene, K. C. (2001). A possible meiotic function of the peculiar patterns of gene expression in mammalian spermatogenic cells. *Mech Dev* **106**, 3–23.
- Kleene, K. C. (2003). Patterns, mechanisms, and functions of translation regulation in mammalian spermatogenic cells. *Cytogenet Genome Res* **103**, 217–224.
- Knee, R., Li, A. W., and Murphy, P. R. (1997). Characterization and tissue-specific expression of the rat basic fibroblast growth factor antisense mRNA and protein. *Proc Natl Acad Sci U S A* **94**, 4943–4947.
- Korneev, S. A., Park, J.-H., and O'Shea, M. (1999). Neuronal expression of neural nitric oxide synthase (nNOS) protein is suppressed by an antisense RNA transcribed from an NOS pseudogene. *J Neurosci* **19**, 7711–7720.
- Laabi, Y., Gras, M. P., Brouet, J. C., Berger, R., Larsen, C. J., and Tsapis, A. (1994). The BCMA gene, preferentially expressed during B lymphoid maturation, is bidirectionally transcribed. *Nucleic Acids Res* **22**, 1147–1154.
- Landers, M., Calciano, M. A., Colosi, D., Glatt-Deeley, H., Wagstaff, J., and Lalande, M. (2005). Maternal disruption of *Ube3a* leads to increased expression of *Ube3a-ATS* in trans. *Nucleic Acids Res* **33**, 3976–3984.
- Lavorgna, G., Dahary, D., Lehner, B., Sorek, B., Sanderson, C. M., and Casari, G. (2004). In search of antisense. *Trends Biochem Sci* **29**, 88–94.
- Lehner, B., Williams, G., Campbell, R. D., and Sanderson, C. M. (2002). Antisense transcripts in the human genome. *Trends Genet* **18**, 63–65.

- Li, T., Vu, T. H., Lee, K. O., Yang, Y., Nguyen, C. V., Bui, H. Q., Zeng, Z. L., Nguyen, B. T., Hu, J. F., Murphy, S. K., *et al.* (2002). An imprinted PEG1/MEST antisense expressed predominantly in human testis and in mature spermatozoa. *J Biol Chem* **277**, 13518–13527.
- Lipman, D. J. (1997). Making (anti)sense of non-coding sequence conservation. *Nucleic Acids Res* **25**, 3580–3583.
- Mattick, J. S. (2004). RNA regulation: a new genetics? *Nat Rev Genet* **5**, 316–323.
- Mattick, J. S., and Makunin, I. V. (2006). Non-coding RNA. *Hum Mol Genet* **15**, R17–R29.
- Mihalich, A., Reina, M., Mangioni, S., Ponti, E., Alberti, L., Vigano, P., Vignali, M., and Di Blasio, A. M. (2003). Different basic fibroblast growth factor and fibroblast growth factor-antisense expression in eutopic endometrial stromal cells derived from women with and without endometriosis. *J Clin Endocrinol Metab* **88**, 2853–2859.
- Morison, I. M., Ramsay, J. P., and Spencer, H. G. (2005). A census of mammalian imprinting. *Trends Genet* **21**, 457–465.
- Mount, S. M. (1982). A catalogue of splice junction sequences. *Nucleic Acids Res* **10**, 459–472.
- Munroe, S. H., and Lazar, M. A. (1991). Inhibition of *c-erbA* mRNA splicing by a naturally occurring antisense RNA. *J Biol Chem* **266**, 22083–22086.
- Neeman, Y., Dahary, D., Levanon, E. Y., Sorek, R., and Eisenberg, E. (2005). Is there any sense in antisense editing? *Trends Genet* **21**, 544–547.
- Nemes, J. P., Benzow, K. A., Moseley, M. L., Ranum, L. P., and Koob, M. D. (2000). The SCA8 transcript is an antisense RNA to a brain-specific transcript encoding a novel actin-binding protein (KLHL1). *Hum Mol Genet* **9**, 1543–1551.
- Nepveu, A., and Marcu, K. B. (1986). Intragenic pausing and anti-sense transcription within the murine *c-myc* locus. *EMBO J* **5**, 2859–2865.
- Nishida, H., Tomaru, Y., Oho, Y., and Hayashizaki, Y. (2005). Naturally occurring antisense RNA of histone H2a in mouse cultured cell lines. *BMC Genet* **6**, 23. doi:10.1186/1471-2156-6-23.
- Ogawa, Y., and Lee, J. T. (2002) Antisense regulation in X inactivation and autosomal imprinting. *Cytogenet Genome Res* **99**, 59–65.
- Pang, A. L.-Y., Taylor, H. C., Johnson, W., Alexander, S., Chen, Y., Su, Y. A., Li, X., Ravindranath, N., Dym, M., Rennert, O. M., *et al.* (2003). Identification of differentially expressed genes in spermatogenesis in the mouse. *J Androl* **24**, 899–911.
- Peters, N. T., Rohrbach, J. A., Zalewski, B. A., Byrskett, C. M., and Vaughn, J. C. (2003). RNA editing and regulation of *Drosophila 4f-rnp* expression by *sas-10* antisense readthrough mRNA transcripts. *RNA* **9**, 698–710.
- Podlowski, S., Bramlage, P., Baumann, G., Morano, I., and Luther, P. (2002). Cardiac troponin I sense-antisense RNA duplexes in the myocardium. *J Cell Biochem* **85**, 198–207.
- Quere, R., Manchon, L., Lejeune, M., Clement, O., Pierrat, F., Bonafoux, B., Commes, T., Piquemal, P., and Marti, J. (2004). Mining SAGE data allows large-scale, sensitive screening of antisense transcript expression. *Nucleic Acids Res* **32**, e163.
- Reis, E. M., Nakaya, H. I., Louro, R., Canavez, F. C., Flatschart, A. V. F., Almeida, G. T., Egidio, C. M., Paquola, A. C., Machado, A. A., Festa, F., *et al.* (2004). Antisense intronic non-coding RNA levels correlate to the degree of tumor differentiation in prostate cancer. *Oncogene* **23**, 6684–6692.

- RIKEN Genome Exploration Research Group and Genome Science Group, and the FANTOM Consortium. (2005). Antisense transcription in the mammalian transcriptome. *Science* **309**, 1564–1566.
- Rinn, J. L., Euskirchen, G., Bertone, P., Martone, R., Luscombe, N. M., Hartman, S., Harrison, P. M., Nelson, F. K., Miller, P., Gerstein, M., et al. (2003). The transcriptional activity of human chromosome 22. *Genes Dev* **17**, 529–540.
- Robb, G. B., Carson, A. R., Tai, S. C., Fish, J. E., Singh, S., Yamada, T., Scherer, S. W., Nakabayashi, K., and Marsden, P. A. (2004). Post-transcriptional regulation of endothelial nitric oxide synthase by an overlapping antisense mRNA transcript. *J Biol Chem* **279**, 37982–37996.
- Rockett, J. C., Christopher Luft, J., Brian Garges, J., Krawetz, S. A., Hughes, M. R., Hee Kirn, K., Oudes, A. J., and Dix, D. J. (2001). Development of a 950-gene DNA array for examining gene expression patterns in mouse testis. *Genome Biol* **2**, research0014.1–research0014.9.
- Rosok, O., and Sioud, M. (2004). Systematic identification of sense-antisense transcripts in mammalian cells. *Nat Biotechnol* **22**, 104–108.
- Rosok, O., and Sioud, M. (2005). Systematic search for natural antisense transcripts in eukaryotes. *Int J Mol Med* **15**, 197–203.
- Rossignol, F., Vache, C., and Clottes, E. (2002). Natural antisense transcripts of hypoxia-inducible factor 1 alpha are detected in different normal and tumor human tissues. *Gene* **299**, 135–140.
- Sam, M., Wurst, W., Kluppel, M., Jin, O., Heng, H., and Berstein, A. (1998). Aquarius, a novel gene isolated by gene trapping with an RNA-dependent RNA polymerase motif. *Dev Dyn* **212**, 304–317.
- Schultz, N., Hamra, F. K., and Garbers, D. L. (2003). A multitude of genes expressed solely in meiotic or postmeiotic spermatogenic cells offers a myriad of contraceptive targets. *Proc Natl Acad Sci U S A* **100**, 12201–12206.
- Seitz, A., Gourevitch, D., Zhang, X. M., Clark, L., Chen, P., Kragol, M., Levenkova, N., Rux, J., Samulewicz, S., and Heber-Katz, E. (2005). Sense and antisense transcripts of the apolipoprotein E gene in normal and ApoE knockout mice, their expression after spinal cord injury and corresponding human transcripts. *Hum Mol Genet* **14**, 2661–2670.
- Sha, J., Zhou, Z., Li, J., Yin, L., Yang, H., Hu, G., Luo, M., Chan, H. C., Spermatogenesis Study Group, and Zhou, K. (2002). Identification of testis development and spermatogenesis-related genes in human and mouse testes using cDNA arrays. *Mol Hum Reprod* **8**, 511–517.
- Shendure, J., and Church, G. M. (2002). Computational discovery of sense-antisense transcription in the human and mouse genome. *Genome Biol* **3**, research0044.1–research0044.14.
- Shi, M., Yan, X., Ryan, D. H., and Harris, R. B. S. (2000). Identification of urocortin mRNA antisense transcripts in rat tissue. *Brain Res Bull* **53**, 317–324.
- Shibata, S., and Lee, J. T. (2004). *Tsix* transcription- versus RNA-based mechanisms in *Xist* repression and epigenetic choice. *Curr Biol* **14**, 1747–1754.
- Shoemaker, D. D., Schadt, E. E., Armour, C. D., He, Y. D., Garrett-Engele, P., McDonagh, P. D., Loerch, P. M., Leonardson, A., Lum, P. Y., Cavet, G., et al. (2001). Experimental annotation of the human genome using microarray technology. *Nature* **409**, 922–927.

- Silverman, T. A., Noguchi, M., and Safer, B. (1992). Role of sequences within the first intron in the regulation of expression of eukaryotic initiation factor 2 α . *J Biol Chem* **267**, 9738–9742.
- Simons, R. W. (1988). Naturally occurring antisense RNA control — a brief review. *Gene* **72**, 35–44.
- Sleutels, F., Zwart, R., and Barlow, D. P. (2002). The non-coding *Air* RNA is required for silencing autosomal imprinted genes. *Nature* **415**, 810–813.
- Solda, G., Boi, S., Duga, S., Fornasari, D., Benfante, R., Malcovati, M., and Tenchini, M. L. (2005). In vivo RNA-RNA duplexes from human alpha3 and alpha5 nicotinic receptor subunit mRNAs. *Gene* **345**, 155–164.
- Spieß, A. N., Walther, N., Müller, N., Balvers, M., Hansis, C., and Ivell, R. (2003). SPEER — a new family of testis-specific genes from the mouse. *Biol Reprod* **68**, 2044–2054.
- Sun, M., Hurst, L. D., Carmichael, G. G., and Chen, J. (2005). Evidence for a preferential targeting of 3'-UTRs by *cis*-encoded natural antisense transcripts. *Nucleic Acids Res* **33**, 5533–5543.
- Tanaka, K., Tamura, H., Tanaka, H., Katoh, M., Futamata, Y., Seki, N., Nishimune, Y., and Hara, T. (2002). Spermatogonia-dependent expression of testicular genes in mice. *Dev Biol* **246**, 466–479.
- Tasheva, E. S., and Roufa, D. J. (1995). Regulation of human RPS14 transcription by intronic antisense RNAs and ribosomal protein S14. *Genes Dev* **9**, 304–316.
- Thrash-Bingham, C. A., and Tartof, K. D. (1999). aHIF: a natural antisense transcript overexpressed in human renal cancer and during hypoxia. *J Natl Cancer Inst* **91**, 143–151.
- Tufarelli, C., Stanley, J. A. S., Garrick, D., Sharpe, J. A., Ayyub, H., Wood, W. G., and Higgs, D. R. (2003). Transcription of antisense RNA leading to gene silencing and methylation as a novel cause of human genetic disease. *Nat Genet* **34**, 157–165.
- Vanhee-Brossollet, C., and Vaquero, C. (1998). Do natural antisense transcripts make sense in eukaryotes? *Gene* **211**, 1–9.
- Veeramachaneni, V., Makalowski, W., Galdzicki, M., Sood, R., and Makalowska, I. (2004). Mammalian overlapping genes: the comparative perspective. *Genome Res* **14**, 280–286.
- Volloch, V., Schweitzer, B., and Rits, S. (1996). Antisense globin RNA in mouse erythroid tissues: structure, origin, and possible function. *Proc Natl Acad Sci USA* **93**, 2476–2481.
- Vu, T. H., Chuyen, N. V., Li, T., and Hoffman, A. R. (2003). Loss of imprinting of *IGF2* sense and antisense transcripts in Wilms' tumor. *Cancer Res* **63**, 1900–1905.
- Wagner, E. G., and Simons, R. W. (1994). Antisense RNA control in bacteria, phages, and plasmids. *Annu Rev Microbiol* **48**, 713–742.
- Wahl, M. B., Heinzmann, U., and Imai, K. (2005). LongSAGE analysis revealed the presence of a large number of novel antisense genes in the mouse genome. *Bioinformatics* **21**, 1389–1392.
- Wang, P. J., McCarrey, J. R., Yang, F., and Page, D. C. (2001). An abundance of X-linked genes expressed in spermatogonia. *Nat Genet* **27**, 422–426.
- Wu, S. M., Baxendale, V., Chen, Y., Li, X., Pang, A. L. Y., Stitely, T., Munson, P. J., Leung, M. Y. K., Ravindranath, N., Dym, M., *et al.* (2004). Analysis of mouse germ cell transcriptome at different stages of spermatogenesis: biological significance. *Genomics* **84**, 971–981.
- Wutz, A., Smrzka, O. W., Schweifer, N., Schellander, K., Wagner, E. F., and Barlow, D. P. (1997). Imprinted expression of the *Igf2r* gene depends on an intronic CpG island. *Nature* **389**, 745–749.

- Yamasaki, K., Joh, K., Ohta, T., Masuzaki, H., Ishimaru, T., Mukai, T., Nikawa, N., Ogawa, M., Wagstaff, J., and Kishino, T. (2003). Neurons but not glial cells show reciprocal imprinting of sense and antisense transcripts of Ube3a. *Hum Mol Genet* **12**, 837–847.
- Yelin, R., Dahary, D., Sorek, R., Levanon, E. Y., Goldstein, O., Shoshan, A., Diber, A., Biton, S., Tamir, Y., Khosravi, R., et al. (2003). Widespread occurrence of antisense transcription in the human genome. *Nat Biotechnol* **21**, 379–386.
- Yu, Z., Guo, R., Ge, Y., Ma, J., Guan, J., Li, S., Sun, X., Xue, S., and Han, D. (2003). Gene expression profiles in different stages of mouse spermatogenic cells during spermatogenesis. *Biol Reprod* **69**, 37–47.
- Zhang, Z., and Gerstein, M. (2004). Large-scale analysis of pseudogenes in the human genome. *Curr Opin Genet Dev* **14**, 328–335.
- Zhang, Z., Harrison, P. M., Liu, Y., and Gerstein, M. (2003). Millions of years of evolution preserved: a comprehensive catalog of the processed pseudogenes in the human genome. *Genome Res* **13**, 2541–2558.

CHAPTER 10

THE SPERMATOGENIAL STEM CELL MODEL

Martin Dym and Zuping He

*Department of Biochemistry and Cell Biology,
Georgetown University Medical Center,
Washington, DC 20057*

Spermatogenesis is the process by which the male germ line stem cells (spermatogonial stem cells) divide and differentiate to produce sperm. Spermatogonial stem cells can be considered “eternal” or “immortal” germ cells because they are present from birth to death, they have the capacity to give rise to new stem cells, and they produce sperm that pass genetic material to the next generation. Thus, they represent a very valuable resource for experimental modification of the mammalian genome. Germ line genetic engineering is a topic still in its infancy, but may well be one of the last frontiers in medicine to be conquered. The idea is to change the human genome in a heritable way, i.e. to fix all known errant genes in the sperm. These would be permanent fixes to be passed from one generation to another. Using velocity sedimentation at unit gravity and BSA gradients, we have isolated highly purified populations of type A spermatogonia. Most of these cells contain the c-kit receptor and respond to stem cell factor (SCF) — these are not considered to be the stem cells in the testis. A subpopulation of the type A spermatogonia is c-kit–negative and possesses the receptor for glial cell line-derived neurotrophic factor (GDNF), GFR α -1. GFR α -1–positive cells were isolated from mouse testes using magnetic beads coated with an antibody recognizing GFR α -1. It is believed that the GFR α -1–positive cells are indeed the true male germ line stem cells in the adult testis. We examined the role of GFR α -1 in type A spermatogonia from 6-day-old mice using RNA interference (RNAi). We demonstrated that *in vitro* GFR α -1 may be required for the proliferation and maintenance of undifferentiated type A spermatogonia, and its knockdown may result in the differentiation of the type A cells.

Keywords: Spermatogonia; stem cells; isolation; characterization; genetic engineering.

Introduction

Spermatogenesis, the process by which type A spermatogonial stem cells divide and differentiate to produce mature spermatids, occurs in the seminiferous tubules of the testis (Fig. 1). The spermatogonial type A stem cells proliferate actively to produce two types of cells: spermatogonial stem cells and differentiating spermatogonia. The differentiating spermatogonia [A_{paired} , A_{aligned} , A_1 – A_4 , intermediate, and type B spermatogonia (in rodents)] divide and give rise to the more specialized meiotic spermatocytes, but they do not divide to produce new stem cells. The type A spermatogonial stem cells (A_0 , A_s cells) are believed to divide slowly to maintain the integrity of the DNA (De Rooij and Russell, 2000; Dym, 1994). A similar scheme of spermatogonial renewal was proposed for monkey and man (Clermont, 1966; Clermont, 1969).

When scientists study liver or embryonic stem cells, it is easy to examine these cells in a dish, identify them with markers, and convince others that the cells under the microscope or in the dish are indeed the cells being studied. However, in the mammalian testes, as in most adult mammalian

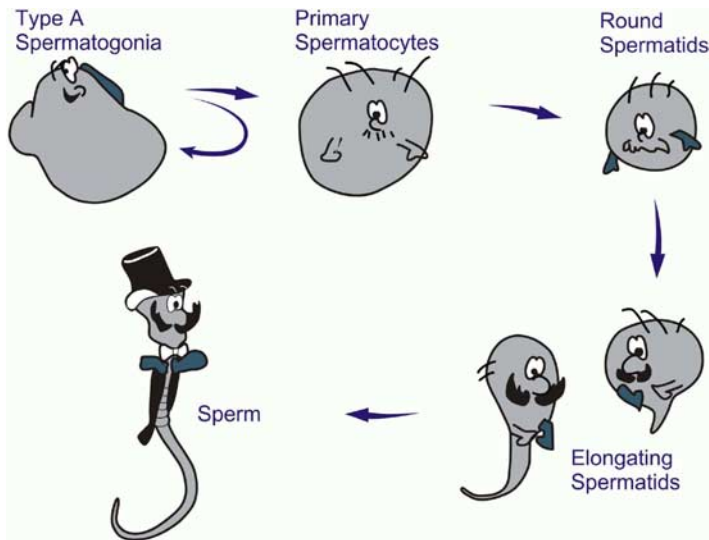

Fig. 1. Spermatogenesis in mammals is depicted in this schematic drawing. The type A spermatogonia contain a subpopulation of cells, the spermatogonial stem cells, which are able to renew themselves (stem cell renewal) and differentiate (stem cell differentiation).

tissues, the precise identity and location of the stem cells still remain largely unknown. The spermatogonial scheme described in the preceding paragraph remains speculative, and more research is needed to identify the true stem cells.

A number of characteristics have been described for stem cells in general (Morrison *et al.*, 1997). The cells are considered to be undifferentiated and capable of proliferation. They are able to self-maintain their own population and are capable of producing differentiated progeny as well. In many tissues, such as liver or muscle, the stem cells have the ability to regenerate tissue after injury. It is also known that the stem cells constitute a small percentage of the total cell population. For example, in most epithelial tissue (including the seminiferous epithelium), the stem cells rest on the basement membrane surrounded by supporting cells. Finally, stem cells often have a large nuclear to cytoplasmic ratio. Stem cells may well be the source of many cancers, since new studies suggest that in every tumor a handful of aberrant stem cells maintain the malignant tissue. Stem cells occupy specialized compartments (a physical microenvironment) in tissues referred to as “niches”. A stem cell niche is a restricted locale in an organ that supports the self-renewing division of stem cells and thus prevents them from differentiating (Spradling *et al.*, 2001; Xie and Spradling, 2000).

Studies on stem cells are important for many reasons; perhaps most prominent is that one day, in the not too distant future, stem cells may help repair diseased tissues via transplantation. The spermatogonial stem cells are adult stem cells, and many of the controversies surrounding embryonic stem cells are not present when adult stem cells are studied. Perhaps the most exciting reason for research of spermatogonial stem cells is the fact that they ultimately give rise to sperm (Fig. 2), which carry the male genome to the next generation. There is the potential use of the testis stem cells for germ line genetic engineering. Germ line genetic engineering is considered one of the last major frontiers in medicine to be conquered. The notion is to change the human genome in a heritable way to fix all known errant genes in the sperm, and these would be permanent fixes to be passed from one generation to another. Advocates argue that however expensive it might be to produce perfectly healthy babies, the cost would be a fraction of the lifetime healthcare otherwise needed (Wivel and Walters, 1993).

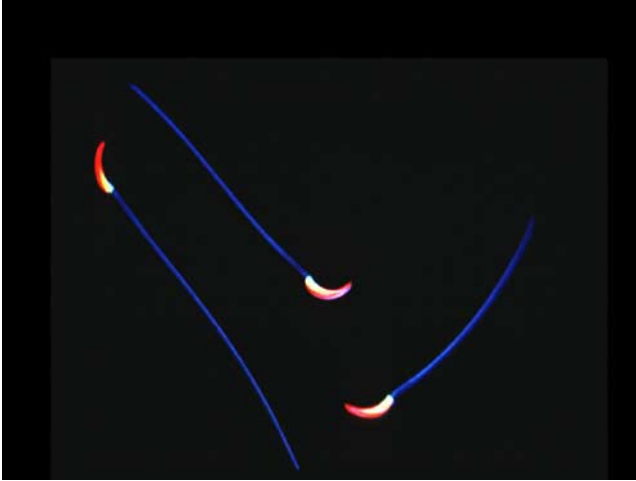

Fig. 2. The end product of the spermatogenic process, the sperm, is depicted in this micrograph. Sperm carry the male genome from generation to generation.

Gain-of-gene and loss-of-gene functions by spermatogonial genetic modification should also shed light on the molecular mechanisms regulating spermatogenesis, ultimately leading to gene therapy of male infertility in the future. *In vivo* electroporation has been shown to be an efficient method for transferring genes to the tissues of living animals. Furthermore, electroporation can be used for any type of tissue or cell, including germ cells. Recently, the combination of microinjecting exogenous DNA directly into mouse seminiferous tubules or the rete testis and subsequent *in vivo* electroporation has been developed (Shoji *et al.*, 2005; Yamaguchi *et al.*, 1998; Yamazaki *et al.*, 1998). This would make it more effective and convenient, using spermatogonial genetic modification, to study the molecular mechanisms of spermatogenesis as well as gene therapy at the whole-organ level.

Isolation and Characterization of Spermatogonial Stem Cells

Until recently, research on stem cell renewal in the testis was limited because of technical difficulties in isolating and identifying these cell populations. In 1977, we described a procedure (STAPUT method) to isolate individual

germ cell types from the mouse testis using a BSA gradient and velocity sedimentation at unit gravity (Bellve *et al.*, 1977). With this technique (Fig. 3), it was possible to obtain a fraction of type A spermatogonial cells from immature mice that were about 90% pure (Fig. 4). We refined the procedure in 1995 and 1996, and added differential plating to help remove

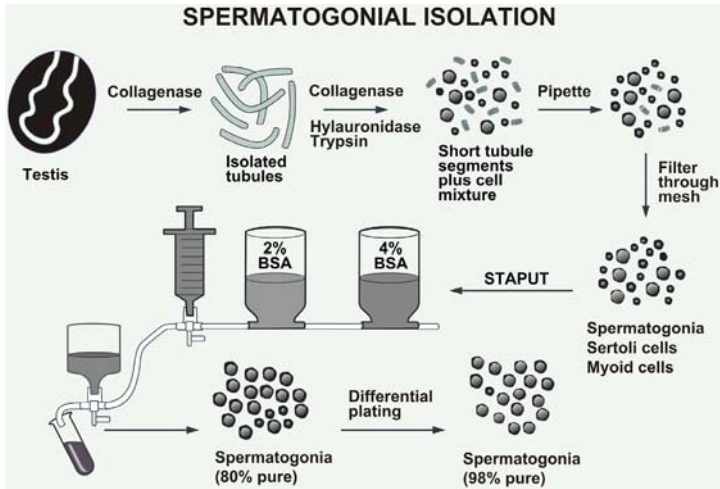

Fig. 3. A schematic drawing showing the STAPUT procedure used to isolate type A spermatogonia. Adapted from Bellve *et al.* (1977).

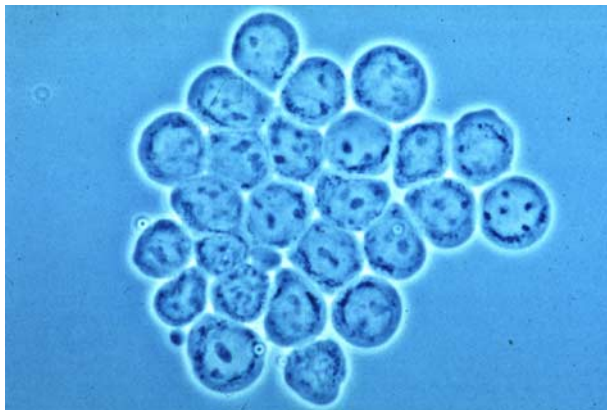

Fig. 4. A phase contrast micrograph showing the purified type A spermatogonia following isolation and purification using the STAPUT procedure.

“contaminating” Sertoli and myoid cells (Dirami *et al.*, 1996; Dym *et al.*, 1995). A number of other investigators used various techniques to isolate the type A spermatogonia from the mouse, but research on the stem cells did not progress very far, mostly because there were no adequate markers that could conclusively establish the identity of the type A cells after isolation.

This problem was partially solved in the late 1980s and early 1990s with the identification of a new growth factor–receptor system (kit ligand/c-kit receptor) important in stem cells regulating melanogenesis, hematopoiesis, and gametogenesis (Besmer, 1991). In the testis, the kit ligand (stem cell factor, steel factor, and mast cell growth factor) is produced by the Sertoli cells; and its receptor, the c-kit receptor, is present in the type A spermatogonial population (Yoshinaga *et al.*, 1991). In addition, it was demonstrated that spermatogonial proliferation is regulated by the Sertoli cell-produced kit ligand. The c-kit receptor could now be used as a marker for the differentiating type A cells. Highly purified populations of these type A cells were isolated from rat, and were characterized by demonstrating the expression of the c-kit receptor at the gene and protein levels. Furthermore, the c-kit receptor was phosphorylated in response to the kit ligand, suggesting that the receptor is indeed an active receptor (Dym *et al.*, 1995). It should now be possible to develop methods that allow for the long-term culture of the type A spermatogonial stem cells.

In 2000, Meng and colleagues published a seminal paper indicating that the spermatogonial stem cells respond to glial-derived neurotrophic factor (GDNF), and that the GFR α -1 receptor (the receptor for GDNF) is present on the spermatogonial stem cells (Meng *et al.*, 2000). We localized the GFR α -1 receptor in seminiferous tubules from immature mice (Dettin *et al.*, 2003). Using immunomagnetic beads, Hoffman and colleagues developed a procedure to isolate very pure populations of the GFR α -1 cells (Hofmann *et al.*, 2005). Approximately 30 000 to 40 000 of these cells could be obtained from 60 immature (6-day-old) mouse pups. The same procedure was also used to isolate the c-kit–positive cells. Figure 5 (right panel) demonstrates the GFR α -1 spermatogonial stem cell (A_{single}) as well as the more differentiated (A_{paired}) c-kit–positive cells (left panel).

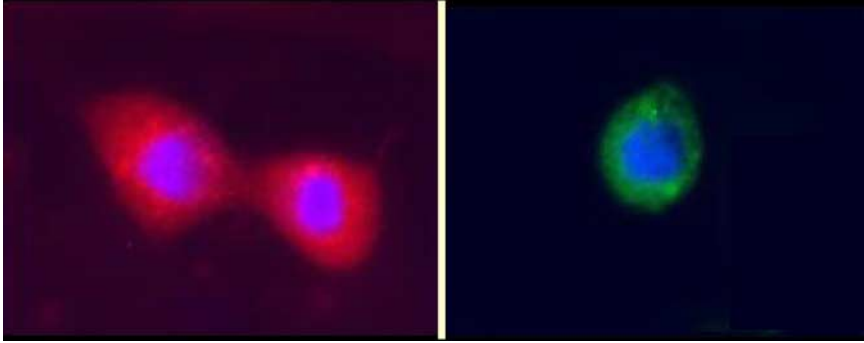

Fig. 5. Following STAPUT isolation and immunomagnetic procedures, the right panel demonstrates the GFR α -1 spermatogonial stem cell (A_{single}) as well as the more differentiated (A_{paired}) c-kit-positive cells (left panel).

Procollagen I in the Spermatogonial Cells

Gene expression analysis of the spermatogonial population by SAGE (serial analysis of gene expression) revealed a number of extracellular matrix components in the cells, including *coll1a1* as the most abundant transcript specific in type A spermatogonia (Wu *et al.*, 2004). Microarray analysis demonstrated that *Coll1a1* and *Coll1a2* were abundantly expressed in the seminiferous tubules of 6-day-old mice compared to 60-day-old mice, and the expression levels of *Coll1a1* and *Coll1a2* mRNA were validated using a semiquantitative RT-PCR assay (He *et al.*, 2005). Western blot analysis further confirmed that procollagen I was expressed at a higher level in the seminiferous tubules of 6-day-old mice compared to 60-day-old mice. Immunohistochemical analysis revealed that type A spermatogonia were positive for procollagen I in the testis of 6-day-old mice, whereas Sertoli cells were negative for this protein (Fig. 6).

The *in vivo* procollagen I staining in type A spermatogonia was corroborated in undifferentiated spermatogonia exhibiting a high potential for proliferation and the ability to form germ cell colonies in *in vitro* culture. Moreover, procollagen I was also detected in type A spermatogonia, intermediate spermatogonia, type B spermatogonia, and preleptotene spermatocytes in the adult mouse testes; but positive staining disappeared in more differentiated germ cell lineages detaching from the basement membrane, including leptotene spermatocytes, pachytene spermatocytes, round

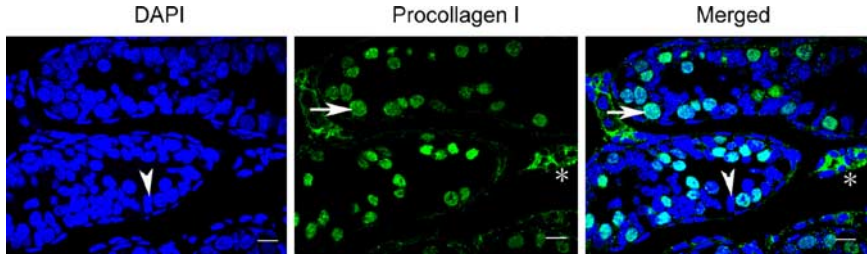

Fig. 6. Immunofluorescent analysis of procollagen I in testis sections derived from 6-day-old mice. Testis sections (5 μm thick) were immunostained and type A spermatogonia (arrows) were positive for procollagen I (green fluorescence — center panel), while Sertoli cells (arrowheads) were negative. Interstitial cells on the outside of the seminiferous tubules also showed staining for procollagen I (asterisks). Staining with DAPI (blue fluorescence) was used to identify the nuclei of all cells found in the section. The scale bar = 10 μm . Adapted from He *et al.* (2005).

spermatids, and elongated spermatids. These data suggest that Colla1, Colla2, and procollagen I are associated with undifferentiated type A spermatogonia, and play a potential role in mediating the detachment and migration of germ cells during spermatogenesis (He *et al.*, 2005).

Synthetic Sex Cells

The spermatogonial stem cells in the testis can be considered as a kind of “eternal” or “immortal” germ cell because they are present from birth to death, and have the capacity to give rise to new type A cells and spermatozoa that can pass genetic material from generation to generation. The ability to obtain a long-term culture of these cells is a long-sought-after goal. Of particular value would be type A stem cells in culture that retain the capacity to differentiate into early spermatocytes and to divide and maintain their own numbers. Furthermore, the retention of the GFR α -1 receptor in the cultured cells would be important, since this growth factor receptor is probably essential for their normal behavior.

In vitro sperm production has been difficult to achieve because of the lack of a culture system to maintain viable spermatogonia for long periods of time. Our laboratory demonstrated the feasibility of obtaining long-term culture of spermatogonial stem cells that retain the capacity to differentiate into round spermatids in culture. We reported the *in vitro* generation of spermatocytes and spermatids from telomerase-immortalized mouse type A

spermatogonial cells in the presence of stem cell factor (Feng *et al.*, 2002). This differentiation can occur in the absence of supportive cells. The immortalized spermatogonial cell line may serve as a powerful tool in elucidating the molecular mechanisms of spermatogenesis. Furthermore, through genomic modification and transplantation techniques, this male germ cell line may be used to generate transgenic mice and to develop germ cell gene therapy.

More recently, several other laboratories have obtained male gametes from embryonic stem cells, although the yield of mature gametes is low (Geijsen *et al.*, 2004; Toyooka *et al.*, 2003). The significance of obtaining gametes from an *in vitro* cell line includes the ability to examine various aspects of sperm production in culture, such as spermatogonial stem cell renewal, meiosis, and spermiogenesis. This will markedly reduce the need for large numbers of experimental animals. Another potential use of the cells is for germ line genetic engineering. If pups could be generated from these gametes, it may enable the expansion of technology to obtain genetically modified rats, pigs, monkeys, baboons, and other species where good embryonic stem cells are difficult to obtain (Fig. 7). This work is ongoing.

Novel Methods of Isolating Testis Stem Cells

The techniques described to date to isolate spermatogonial stem cells are generally tedious, expensive, and result in a low yield. Stem cell biology in general, but particularly in solid tissues, still suffers from a lack of specific cell surface markers that unambiguously label all stem cells. The ability to purify stem cells relies on the expression of appropriate cell surface antigens, immunostaining of the antigens with fluorescently conjugated antibodies, and then isolation by fluorescent-activated cell sorting (FACS). One approach that our lab is pursuing combines the STAPUT procedure that we described years ago followed by FACS. The STAPUT procedure should allow a far purer population of cells to be loaded onto the FACS sorter. Using these techniques, it may be possible to succeed in isolating spermatogonial stem cells from the adult testes.

As noted above, adequate markers for stem cells are still lacking; as a result, other methods not dependent upon cell surface antigens have been developed to isolate these cells. In the hematopoietic system, purification

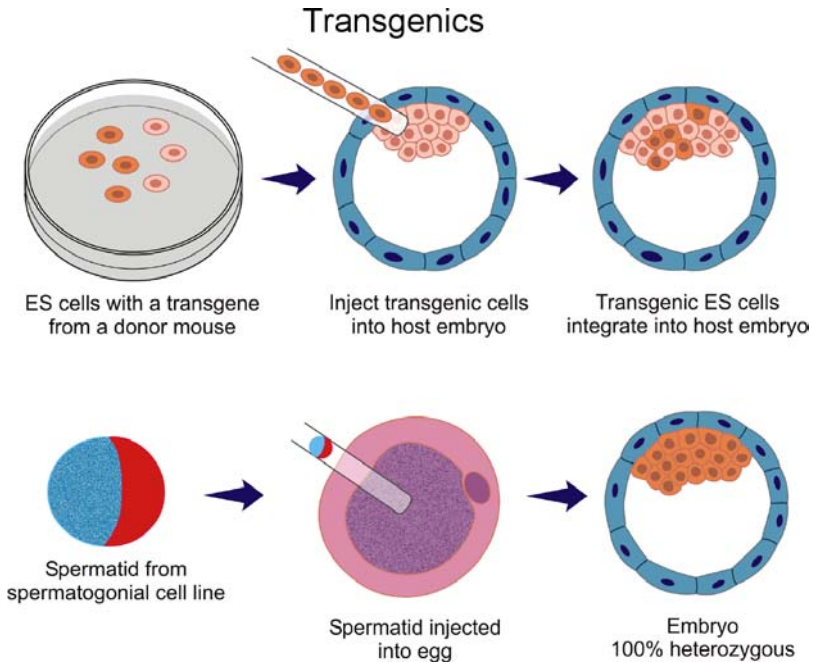

Fig. 7. The top panel depicts the traditional method of generating transgenics. This requires multiple matings and is time-consuming. The bottom panel indicates a spermatid (from a cell line) used to fertilize an egg. Embryos derived in this manner are 100% heterozygous.

strategies have taken advantage of differential staining patterns with vital dyes such as Rhodamine 123 or Hoechst 33342 (Goodell *et al.*, 1996). A defining property of hematopoietic stem cells is low fluorescence after staining with Hoechst 33342. This so-called “side population” (SP) of cells are identified by their ability to efflux the dye at a greater rate than other cells within the bone marrow. The degree of efflux is correlated with the maturation state, such that cells exhibiting the highest efflux activity are the most primitive cells. The Hoechst efflux phenomenon has proven to be a highly useful primary purification strategy for isolating stem cells from various tissues in the absence of cell surface markers. Cells with an SP phenotype have now been described in many solid tissues, including skeletal muscle, lung, heart, kidney, skin, brain, mammary gland, and testis (Hoechst low-SP phenotype) (Challen and Little, 2006).

The identification of testicular stem cells using the Hoechst efflux phenomenon still remains controversial, since conflicting results have been obtained with this cell type and testicular transplantation (Falciatori *et al.*, 2004; Kubota *et al.*, 2003). Perhaps the best promise for the eventual isolation of spermatogonial stem cells is with the eventual identification of unambiguous markers that will allow for their isolation and purification by FACS in large numbers. The gene expression studies with SAGE technology by Wu and colleagues may eventually lead to the identification of these markers (Wu *et al.*, 2004).

Summary

Spermatogenesis and spermatogonial stem cell renewal and differentiation were studied extensively in the 1960s and early 1970s by Clermont and colleagues (Clermont and Leblond, 1953; Clermont and Leblond, 1955; Clermont and Leblond, 1959; Dym and Clermont, 1970). Except for the work of De Rooij and colleagues (for review see De Rooij, 1998; De Rooij, 2001; De Rooij and Grootegoed, 1998; De Rooij *et al.*, 1989) and Meistrich and colleagues (for review see Meistrich, 1972; Meistrich, 1984; Meistrich *et al.*, 1985; Meistrich and van Beek, 1993), the field received scant attention from most scientists until the mid-1990s, when Brinster and colleagues elegantly demonstrated the feasibility of transplanting these stem cells to the seminiferous tubules of sterile mice (Brinster and Avarbock, 1994; Brinster and Zimmerman, 1994). The pre-eminent importance of the spermatogonial stem cell is now recognized, because it is possible to modify the male genome using this male germ line stem cell.

Acknowledgments

Support for this research was from NIH grant number HD033728.

References

- Bellve, A. R., Cavicchia, J. C., Millette, C. F., O'Brien, D. A., Bhatnagar, Y. M., and Dym, M. (1977). Spermatogenic cells of the prepuberal mouse: isolation and morphological characterization. *J Cell Biol* **74**, 68–85.
- Besmer, P. (1991). The kit ligand encoded at the murine Steel locus: a pleiotropic growth and differentiation factor. *Curr Opin Cell Biol* **3**, 939–946.

- Brinster, R. L., and Avarbock, M. R. (1994). Germline transmission of donor haplotype following spermatogonial transplantation. *Proc Natl Acad Sci U S A* **91**, 11303–11307.
- Brinster, R. L., and Zimmerman, J. W. (1994). Spermatogenesis following male germ cell transplantation. *Proc Natl Acad Sci U S A* **91**, 11298–11302.
- Challen, G. A., and Little, M. H. (2006). A side order of stem cells: the SP phenotype. *Stem Cells* **24**, 3–12.
- Clermont, Y. (1966). Renewal of spermatogonia in man. *Am J Anat* **118**, 509–524.
- Clermont, Y. (1969). Two classes of spermatogonial stem cells in the monkey (*Cercopithecus aethiops*). *Am J Anat* **126**, 57–71.
- Clermont, Y., and Leblond, C. P. (1953). Renewal of spermatogonia in the rat. *Am J Anat* **93**, 475–501.
- Clermont, Y., and Leblond, C. P. (1955). Spermiogenesis of man, monkey, ram and other mammals as shown by the periodic acid-Schiff technique. *Am J Anat* **96**, 229–253.
- Clermont, Y., and Leblond, C. P. (1959). Differentiation and renewal of spermatogonia in the monkey, *Macacus rhesus*. *Am J Anat* **104**, 237–273.
- De Rooij, D. G. (1998). Stem cells in the testis. *Int J Exp Pathol* **79**, 67–80.
- De Rooij, D. G. (2001). Proliferation and differentiation of spermatogonial stem cells. *Reproduction* **121**, 347–354.
- De Rooij, D. G., and Grootegoed, J. A. (1998). Spermatogonial stem cells. *Curr Opin Cell Biol* **10**, 694–701.
- De Rooij, D. G., and Russell, L. D. (2000). All you wanted to know about spermatogonia but were afraid to ask. *J Androl* **21**, 776–798.
- De Rooij, D. G., Van Dissel-Emiliani, F. M. F., and Van Pelt, A. M. M. (1989). Part V. The seminiferous tubule. Regulation of spermatogonial proliferation. *Ann NY Acad Sci* **564**, 140–153.
- Detin, L., Ravindranath, N., Hofmann, M. C., and Dym, M. (2003). Morphological characterization of the spermatogonial subtypes in the neonatal mouse testis. *Biol Reprod* **69**, 1565–1571.
- Dirami, G., Ravindranath, N., Jia, M. C., and Dym, M. (1996). Isolation and culture of immature rat type A spermatogonial stem cells. In: *Ernst Schering Research Foundation Workshop. Signal Transduction in Testicular Cells*, V. Hansson, F. O. Levy, & K. Taskén, eds., Springer-Verlag, Berlin, pp. 141–166.
- Dym, M. (1994). Spermatogonial stem cells of the testis. *Proc Natl Acad Sci U S A* **91**, 11287–11289.
- Dym, M., and Clermont, Y. (1970). Role of spermatogonia in the repair of the seminiferous epithelium following X-irradiation of the rat testis. *Am J Anat* **128**, 265–282.
- Dym, M., Jia, M. C., Dirami, G., Price, J. M., Rabin, S. J., Mocchetti, I., and Ravindranath, N. (1995). Expression of c-kit receptor and its autophosphorylation in immature rat type A spermatogonia. *Biol Reprod* **52**, 8–19.
- Falcatori, I., Borsellino, G., Haliassos, N., Boitani, C., Corallini, S., Battistini, L., Bernardi, G., Stefanini, M., and Vicini, E. (2004). Identification and enrichment of spermatogonial stem cells displaying side-population phenotype in immature mouse testis. *FASEB J* **18**, 376–378.

- Feng, L. X., Chen, Y., Dettin, L., Pera, R. A., Herr, J. C., Goldberg, E., and Dym, M. (2002). Generation and in vitro differentiation of a spermatogonial cell line. *Science* **297**, 392–395.
- Geijsen, N., Horoschak, M., Kim, K., Gribnau, J., Eggan, K., and Daley, G. Q. (2004). Derivation of embryonic germ cells and male gametes from embryonic stem cells. *Nature* **427**, 148–154.
- Goodell, M. A., Brose, K., Paradis, G., Conner, A. S., and Mulligan, R. C. (1996). Isolation and functional properties of murine hematopoietic stem cells that are replicating in vivo. *J Exp Med* **183**, 1797–1806.
- He, Z., Feng, L., Zhang, X., Geng, Y., Parodi, D. A., Suarez-Quian, C., and Dym, M. (2005). Expression of Col1a1, Col1a2 and procollagen I in germ cells of immature and adult mouse testis. *Reproduction* **130**, 333–341.
- Hofmann, M. C., Braydich-Stolle, L., and Dym, M. (2005). Isolation of male germ-line stem cells; influence of GDNF. *Dev Biol* **279**, 114–124.
- Kubota, H., Avarbock, M. R., and Brinster, R. L. (2003). Spermatogonial stem cells share some, but not all, phenotypic and functional characteristics with other stem cells. *Proc Natl Acad Sci U S A* **100**, 6487–6492.
- Meistrich, M. L. (1972). Separation of mouse spermatogenic cells by velocity sedimentation. *J Cell Physiol* **80**, 299–312.
- Meistrich, M. L. (1984). Stage-specific sensitivity of spermatogonia to different chemotherapeutic drugs. *Biomed Pharmacother* **38**, 137–142.
- Meistrich, M. L., Bucci, L. R., Trostle-Weige, P. K., and Brock, W. A. (1985). Histone variants in rat spermatogonia and primary spermatocytes. *Dev Biol* **112**, 230–240.
- Meistrich, M. L., and van Beek, M. E. A. B. (1993). Spermatogonial stem cells. In: *Cell and Molecular Biology of the Testis*, C. Desjardins & L. L. Ewing, eds., Oxford University Press, New York, pp. 266–295.
- Meng, X., Lindahl, M., Hyvonen, M. E., Parvinen, M., De Rooij, D. G., Hess, M. W., Raatikainen-Ahokas, A., Sainio, K., Rauvala, H., Lakso, M., *et al.* (2000). Regulation of cell fate decision of undifferentiated spermatogonia by GDNF. *Science* **287**, 1489–1493.
- Morrison, S. J., Shah, N. M., and Anderson, D. J. (1997). Regulatory mechanisms in stem cell biology. *Cell* **88**, 287–298.
- Shoji, M., Chuma, S., Yoshida, K., Morita, T., and Nakatsuji, N. (2005). RNA interference during spermatogenesis in mice. *Dev Biol* **282**, 524–534.
- Spradling, A., Drummond-Barbosa, D., and Kai, T. (2001). Stem cells find their niche. *Nature* **414**, 98–104.
- Toyooka, Y., Tsunekawa, N., Akasu, R., and Noce, T. (2003). Embryonic stem cells can form germ cells in vitro. *Proc Natl Acad Sci U S A* **100**, 11457–11462.
- Wivel, N. A., and Walters, L. (1993). Germ-line gene modification and disease prevention: some medical and ethical perspectives. *Science* **262**, 533–538.
- Wu, S. M., Baxendale, V., Chen, Y., Pang, A. L., Stitely, T., Munson, P. J., Leung, M. Y., Ravindranath, N., Dym, M., Rennert, O. M., and Chan, W. Y. (2004). Analysis of mouse germ cell transcriptome at different stages of spermatogenesis by SAGE: biological significance. *Genomics* **84**, 971–981.

- Xie, T., and Spradling, A. C. (2000). A niche maintaining germ line stem cells in the *Drosophila* ovary. *Science* **290**, 328–330.
- Yamaguchi, Y., Nozawa, K., Savoysky, E., Hayakawa, N., Nimura, Y., and Yoshida, S. (1998). Change in telomerase activity of rat organs during growth and aging. *Exp Cell Res* **242**, 120–127.
- Yamazaki, Y., Fujimoto, H., Ando, H., Ohyama, T., Hirota, Y., and Noce, T. (1998). In vivo gene transfer to mouse spermatogenic cells by deoxyribonucleic acid injection into seminiferous tubules and subsequent electroporation. *Biol Reprod* **59**, 1439–1444.
- Yoshinaga, K., Nishikawa, S., Ogawa, M., Hayashi, S., Kunisada, T., and Fujimoto, T. (1991). Role of c-kit in mouse spermatogenesis: identification of spermatogonia as a specific site of c-kit expression and function. *Development* **113**, 689–699.

CHAPTER 11

TRANSPLANTATION OF GERM CELLS AND TESTIS TISSUE

Ina Dobrinski

*Center for Animal Transgenesis and Germ Cell Research,
School of Veterinary Medicine,
University of Pennsylvania,
Kennett Square, PA*

Transplantation of germ line stem cells from a fertile donor to the testis of an infertile recipient mouse restores donor-derived spermatogenesis in the recipient testis, and the resulting sperm pass the donor genotype to the offspring of the recipient. Germ cell transplantation provides a bioassay to study the biology of these stem cells and their niche in the testis. While it has long been difficult to isolate and culture spermatogonial stem cells, recent progress in stem cell identification and primary culture as well as the report of several spermatogonial cell lines have opened up seemingly endless possibilities to study and manipulate male germ line stem cells *in vitro* and *in vivo*. Germ cell transplantation in rodents is increasingly employed to investigate whether a phenotype of infertility originated from a defect in Sertoli cells or in germ cells. Transplantation of transfected germ cells has been investigated as an alternate means to introduce genetic changes into the male germ line. This approach has tremendous potential in species like the rat and domestic animals, where embryonic stem cell technology is not available. Although most widely studied in rodents, germ cell transplantation has been applied to larger mammals, including primates. Potential clinical applications include restoration of fertility in patients after sterilizing treatments for cancer, or targeted correction of genetic defects in testicular somatic cells. More recently, as an alternative to transplantation of isolated germ cells, ectopic grafting of testis tissue from diverse donor species, including primates, into a mouse host has opened up additional possibilities to study spermatogenesis and to produce fertile sperm from immature donors. Maturation of testis tissue from immature rhesus monkeys could be significantly accelerated in a mouse host, thereby providing a convenient *in vivo* system for the study and manipulation of primate spermatogenesis. Testis xenografts are ideally suitable to study toxicants or drugs with the potential to enhance or suppress male fertility, without the necessity of performing experiments in the target species. Therefore, transplantation of germ cells and xenografting of testis tissue

represent powerful approaches for the study, preservation, and manipulation of male fertility in a variety of mammalian species.

Keywords: Male germ line; stem cell; testis; grafting.

Introduction

Spermatogenesis is a continuous, highly organized process comprised of sequential steps of cell proliferation and differentiation, resulting in the production of virtually unlimited numbers of spermatozoa throughout the life of the male (Russell *et al.*, 1990). The foundation of this system is the spermatogonial stem cell, which has the potential for both self-renewal and production of differentiated daughter cells that will ultimately form spermatozoa (Huckins, 1971; Clermont, 1972; Meistrich and van Beek, 1993). Among the stem cells in a male individual, the spermatogonial stem cell is unique in that it is the only cell in the adult body that divides and can contribute genes to subsequent generations.

Because stem cells are ultimately defined by function, unequivocal identification depends on an assay to demonstrate the potential to reconstitute the appropriate body system. This assay became available for spermatogonial stem cells when, in 1994, Dr Ralph Brinster and colleagues at the University of Pennsylvania reported that transplantation of germ cells from fertile donor mice to the testes of infertile recipient mice results in donor-derived spermatogenesis and sperm production by the recipient animal (Brinster and Zimmermann, 1994). The use of donor males carrying the bacterial β -galactosidase gene allowed for identification of donor-derived spermatogenesis in the recipient mouse testis, and established the fact that donor haplotype is passed on to the offspring by recipient animals (Brinster and Avarbock, 1994).

Technical Aspects of Germ Cell Transplantation

In the years following the initial report of the technique, several important steps were accomplished. In 1995, Jiang and Short (1995) applied the technique to germ cell transplantation between rats (subsequently also reported by Ogawa *et al.*, 1999b; Zhang *et al.*, 2003). A detailed technical analysis of the technique was published (Ogawa *et al.*, 1997) and, in 1999,

we established an image analysis approach that allows quantification of the colonization of recipient testes by donor stem cells (Dobrinski *et al.*, 1999b).

In 1996, Brinster's group showed that mouse spermatogonial stem cells can be cryopreserved for prolonged periods of time before transplantation and still establish spermatogenesis in the recipient testis (Avarbock *et al.*, 1996). Different from cryopreservation of sperm that represents a finite quantity of male germ cells, freezing of male germ line stem cells virtually preserves the entire genetic potential of a given male since, following transplantation, these cells will continue to replicate and undergo meiotic recombination. While cryopreservation protocols have to be developed empirically for each species due to the highly specialized cellular architecture of the sperm, germ line stem cells can be frozen successfully in diverse species using a standard cell culture freezing protocol (Avarbock *et al.*, 1996; Dobrinski *et al.*, 1999a; Dobrinski *et al.*, 2000; Nagano *et al.*, 2001b; Nagano *et al.*, 2002a).

Characterization of Spermatogonial Stem Cells

Germ cell transplantation, for the first time, provided an unequivocal functional reconstitution assay that made it possible to characterize putative spermatogonial stem cells. Transplantation of genetically marked germ cells (Zambrowicz *et al.*, 1997; Ventela *et al.*, 2002) provides a unique opportunity to study the events of spermatogenesis by following individual stem cells from the moment of transplantation into a recipient testis up to complete sperm production. The temporal and spatial sequences of these steps appear to be dependent on a specific distribution and density of germ cells along the tubule (Ventela *et al.*, 2002; Parreira *et al.*, 1998; Nagano *et al.*, 1999). Experiments using serial dilution of donor cells (Dobrinski *et al.*, 1999b) as well as serial transplantation experiments supported the "one stem cell—one colony" hypothesis and established a homing efficiency of 4%–12% (Ogawa *et al.*, 2003; Kanatsu-Shinohara *et al.*, 2003c; Nagano, 2003). Sperm arising from transplanted donor germ cells are capable of fertilization *in vivo* and *in vitro* (Brinster and Avarbock, 1994; Goossens *et al.*, 2003; Honaramooz *et al.*, 2003b).

It has been estimated that there are only about 2×10^4 stem cells in 10^8 cells of a mouse testis (Meistrich and van Beek, 1993; Tegelenbosch and de Rooij, 1993). In order to study the biology of these stem cells, it was

therefore desirable to obtain populations of cells enriched in spermatogonial stem cells from testis cell preparations. Work in the mouse focused on the characterization of and enrichment for putative stem cells. Initially, it was shown that the selection of germ cells for expression of α_6 - and β_1 -integrin in the absence of c-kit receptor, as well as the collection of cells from experimentally induced cryptorchid testes, resulted in a significant enrichment for spermatogonial stem cells (Shinohara *et al.*, 1999; Shinohara *et al.*, 2000a; Shinohara *et al.*, 2000b). A subsequent study further characterized the antigenic phenotype of putative spermatogonial stem cells (Kubota *et al.*, 2003); however, there were conflicting reports on whether “side population” cells that actively exclude Hoechst dye represent a cell population enriched in germ line stem cells, as reported for other stem cell systems (Kubota *et al.*, 2003; Lassalle *et al.*, 2004). More recently, the expression of Thy-1, CD9, and Egr3 — surface proteins also expressed on embryonic or bone marrow stem cells — was utilized as markers for the enrichment of mouse germ line stem cell populations (Kubota *et al.*, 2003; Kubota *et al.*, 2004a; Kanatsu-Shinohara *et al.*, 2004b; Hamra *et al.*, 2004).

Characterization of the Stem Cell Niche

The success of germ cell transplantation requires the availability of a stem cell niche in the recipient testis. Although much attention was initially focused on the fate of donor cells in the recipient testis, it quickly became evident that the environment of the recipient testis plays a crucial role in the dynamics and efficiency of donor cell colonization. Initial studies used mutant mice that were inherently devoid of germ cells. Alternatively, endogenous spermatogenesis in recipient animals can be depleted by irradiation (Creemers *et al.*, 2002; Schlatt *et al.*, 2002a) or by treatment with the alkylating agent busulfan (Bucci and Meistrich, 1987), a strategy now widely used in preparing recipient mice (Brinster and Avarbock, 1994; Ogawa *et al.*, 1997; Vecino *et al.*, 2001). This approach, however, cannot be easily adapted to other species due to species-specific sensitivity to busulfan, notably its suppressive effect on bone marrow function and testicular health (Ogawa *et al.*, 1999b; Brinster *et al.*, 2003; Honaramooz *et al.*, 2005). Adverse effects of busulfan on testicular health can be partially overcome by treatment with estradiol and by suppression of testosterone through GnRH agonists (Ogawa *et al.*, 1999b; Vecino *et al.*, 2001; Ogawa *et al.*,

1998). Treatment of pregnant females with busulfan and subsequent use of the male offspring as recipients provide a promising alternate approach (Brinster *et al.*, 2003; Honaramooz *et al.*, 2005).

Studies exploring different recipient animal models have also been directed at determining the effect of recipient age on the success of transplantation. The immature mouse testis provides a superior microenvironment for donor cell colonization compared to the adult testis (Shinohara *et al.*, 2001). The seminiferous tubules in prepubertal animals even without cytotoxic treatment contain only Sertoli cells and primitive germ cells, and the Sertoli cell tight junctions are not completely formed, facilitating the use of these animals as germ cell recipients. These properties of the prepubertal recipient testis were successfully exploited in germ cell transplantation in nonrodent species (Honaramooz *et al.*, 2002a; Honaramooz *et al.*, 2003b).

As outlined above, the recipient testicular environment directly influences the efficiency of donor cell colonization. Studies on the recolonization of testes after destruction of spermatogenesis by chemotherapy showed that lowering intratesticular testosterone concentration improves spermatogenic recovery in rats (Kangasniemi *et al.*, 1995). Accordingly, quantitative analysis of germ cell transplantation experiments in mice demonstrated that the suppression of testosterone production in recipient animals prior to and after germ cell transplantation by treatment with GnRH agonists enhances donor-derived colonization of the testes (Ogawa *et al.*, 1998; Dobrinski *et al.*, 2001). The mechanism behind this observation is not entirely clear, but it appears to be independent of the SCF/c-kit signaling pathway (Ohmura *et al.*, 2003). More recently, a morphological characterization of stem cells and the development of the stem cell niche have also been presented for the rat (Orwig *et al.*, 2002b; Ryu *et al.*, 2003; Ryu *et al.*, 2004).

Germ Cell Culture

The culture of germ cells has long been elusive, and it was generally accepted that stem cells could not be maintained in culture for more than a few days. However, the availability of the transplantation assay system has made it possible to develop and improve culture conditions for spermatogonial stem cells. Nagano *et al.* (1998) first showed that stem cells could be maintained in culture for a long period of time. Improving culture conditions for male germ

line stem cells is still under intense study, as evidenced by recent reports of improved culture systems for mouse germ cells (Kanatsu-Shinohara *et al.*, 2003a; Jeong *et al.*, 2003). Coculture with embryonic fibroblast or bone marrow stromal cells, but not Sertoli cell lines, and the addition of several growth factors known to be beneficial for the culture of other stem cell types or primordial germ cells — such as glial cell line-derived neurotrophic factor (GDNF), leukemia inhibitory factor (LIF), epidermal growth factor (EGF), and basic fibroblast growth factor (bFGF) — successfully maintained mouse germ line stem cells in culture for varying periods of time (Nagano *et al.*, 1998; Nagano *et al.*, 2003; Kanatsu-Shinohara *et al.*, 2003a). Recently, two groups reported an efficient long-term culture system for mouse spermatogonial stem cells (Kubota *et al.*, 2004b; Kanatsu-Shinohara *et al.*, 2005).

Transplantation experiments demonstrated the developmental potential of mouse primordial germ cells to initiate spermatogenesis when transplanted into a postnatal testis (Chuma *et al.*, 2005), and it was subsequently reported that pluripotent stem cells could be isolated from cultures of neonatal mouse testis cells (Kanatsu-Shinohara *et al.*, 2004a). It appears that multipotent cells persist in the neonatal mouse testis that will preferentially proliferate under specific culture conditions, as was previously reported for multipotent cells isolated from porcine fetal fibroblast cultures (Dyce *et al.*, 2004; Kues *et al.*, 2005). The majority of the work to date has been performed with primary cultures of putative male germ line stem cells. While progress in this area has been significant, the availability of immortalized cell lines would provide tremendous potential for the study and manipulation of male germ cells *in vitro*. To date, there are reports of immortalized germ cell lines from rat and mouse (van Pelt *et al.*, 2002; Feng *et al.*, 2002; Hofmann *et al.*, 2005).

Characterization of Spermatogenic Defects

Since 2000, germ cell transplantation in rodents has been increasingly employed to investigate whether a phenotype of infertility originated from a defect in Sertoli cells or in germ cells (Fig. 1). Initially, we demonstrated that transplantation of germ cells from infertile Steel mutant mice to infertile W/W^v mutant mice could restore fertility (Ogawa *et al.*, 2000). Subsequently, germ cell transplantation was used to characterize the roles of c-kit and SCF in the regulation of germ cell proliferation (Ohta *et al.*, 2000)

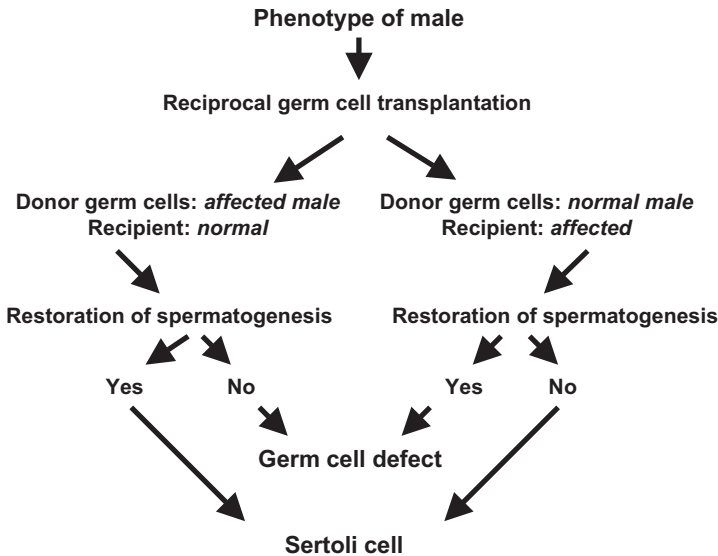

Fig. 1. Application of germ cell transplantation to characterize defects in spermatogenesis. Reciprocal transplantation between affected animals and normal, fertile controls can determine the cellular localization of the defect. If germ cells from an affected animal can restore spermatogenesis in a normal testicular environment, but normal germ cells cannot sustain spermatogenesis in the affected animal, then the defect is localized in the somatic cells. Conversely, if normal germ cells can restore spermatogenesis in the affected animal, but affected germ cells cannot support spermatogenesis in the normal testis, then the defect is localized in the germ cells of the affected animal. Reprinted with permission from Dobrinski (2005).

in order to show that the defect associated with the juvenile spermatogonial depletion (*jsd*) mutation is inherent to the germ cells (Boettger-Tong *et al.*, 2000b; Ohta *et al.*, 2001), that germ cells do not require estrogen receptors (Mahato *et al.*, 2000) or androgen receptors (Johnston *et al.*, 2001) for development, and that germ cell differentiation is regulated by GDNF (Creemers *et al.*, 2002; Yomogida *et al.*, 2003) and CREM function (Wistuba *et al.*, 2002).

Transplantation of wild-type germ cells into the testes of *Dazl*-null mice established that the somatic compartment of the *Dazl*-null testes remains functional (Rilianawati *et al.*, 2003). More recently, *plzf* has been shown by reciprocal transplantation experiments using mutant and wild-type strains to be essential for stem cell self-renewal in the mouse (Buaas *et al.*, 2004; Costoya *et al.*, 2004). In the rat, germ cell transplantation experiments

Table 1. Use of germ cell transplantation to characterize mutants with a phenotype of disrupted spermatogenesis.

Mutant strain (description)	Characterization of defect by reciprocal germ cell transplantation	Reference
SI/SI ^d and W/W ^v (defects in Steel factor–c-kit signaling system)	Germ cells from infertile SI/SI ^d donor mouse can restore fertility in infertile W/W ^v recipient mouse	Ogawa <i>et al.</i> (2000)
<i>Jsd</i> (juvenile spermatogonial depletion)	Defect causing progressive loss of spermatogenesis is inherent to germ cells	Boettger-Tong <i>et al.</i> (2000a), Ohta <i>et al.</i> (2001)
ERKO (estrogen receptor alpha knockout)	Germ cells do not require functional estrogen receptor	Mahato <i>et al.</i> (2000)
ARKO (androgen receptor knockout)	Germ cells do not require functional androgen receptor	Johnston <i>et al.</i> (2001)
GDNF (overexpression of glial cell line-derived neurotrophic factor)	Phenotype of increased spermatogonial proliferation vs. decreased differentiation is inherent to germ cells	Creemers <i>et al.</i> (2002)
CREM (cAMP response element modulator)	Germ cell differentiation is dependent on CREM function	Wistuba <i>et al.</i> (2002)
<i>As</i> -mutant rat	Defect of germ cells and blood–testis barrier	Noguchi <i>et al.</i> (2002)
<i>Dazl</i> (deleted in azoospermia) knockout	Somatic compartment of the knockout testis is functional	Rilianawati <i>et al.</i> (2003)
Luxoid mutant mouse	<i>Plzf</i> is required for stem cell self-renewal	Buaas <i>et al.</i> (2004), Costoya <i>et al.</i> (2004)

elucidated the defect underlying the *as* mutation (Noguchi *et al.*, 2002). This list is continuously growing, as new rodent models with male infertility phenotypes become available (Table 1).

Germ Cell Transplantation Between Different Species

In 1996, the production of rat sperm in mouse testes was achieved following cross-species (xenogeneic) spermatogonial transplantation from rats to

mice (Clouthier *et al.*, 1996), and was subsequently successful from mice to rats (Ogawa *et al.*, 1999b; Zhang *et al.*, 2003). Cross-species transplantation showed that the cell cycle during spermatogenesis is controlled by the germ cell, not the Sertoli cell (Franca *et al.*, 1998). For its obvious practical potential, cross-species germ cell transplantation was explored further. Hamster spermatogenesis occurred successfully in the mouse host (Ogawa *et al.*, 1999a); however, with increasing phylogenetic distance between donor and recipient species, complete spermatogenesis could no longer be achieved in the mouse testis. Transplantation of germ cells from nonrodent donors ranging from rabbits and dogs to pigs and bulls, and ultimately nonhuman primates and humans, resulted in colonization of the mouse testis, but spermatogenesis became arrested at the stage of spermatogonial expansion (Dobrinski *et al.*, 1999a; Dobrinski *et al.*, 2000; Nagano *et al.*, 2001b; Nagano *et al.*, 2002a).

It appears that the initial steps of germ cell recognition by the Sertoli cells, localization to the basement membrane, and initiation of spermatogonial proliferation are conserved between evolutionarily divergent species. However, it was hypothesized that with increasing divergence between donor and recipient species, the recipient testicular environment (comprised of Sertoli cells and paracrine factors) becomes unable to support spermatogenic differentiation and meiosis. This incompatibility of donor germ cells and recipient testicular environment was overcome by cotransplantation of germ cells and Sertoli cells (Shinohara *et al.*, 2003) or by testis tissue transplantation (Honaramooz *et al.*, 2002b). Although xenogeneic spermatogonial transplantation did not have the envisioned immediate practical application, it nonetheless provides a bioassay for the stem cell potential of germ cells isolated from other species (Dobrinski *et al.*, 1999a; Dobrinski *et al.*, 2000; Izadyar *et al.*, 2002) as well as a tool to study cellular and noncellular requirements of spermatogenesis in diverse species.

Germ Cell Transplantation in Higher Mammalian Species

While the majority of the work is performed in rodent models, germ cell transplantation is now also applied to nonrodent species like pigs, goats, cattle, and primates (Honaramooz *et al.*, 2002a; Honaramooz *et al.*, 2003a; Honaramooz *et al.*, 2003b; Izadyar *et al.*, 2003; Schlatt *et al.*, 2002a). The

application of germ cell transplantation technology to nonrodent species has been difficult. Due to differences in testicular anatomy and physiology, germ cells cannot be delivered by the same technique as in rodents. Instead, by combining ultrasound-guided cannulation of the centrally located rete testis with the delivery of germ cells by gravity flow, we succeeded in transplanting donor cells from transgenic donor goats into the testes of immunocompetent, prepubertal recipient animals (Honaramooz *et al.*, 2003b). Once these goats became sexually mature, they produced sperm carrying the donor haplotype and transmitted the donor genetic makeup to the offspring. This provided proof of principle that germ cell transplantation results in donor-derived sperm production and fertility in a nonrodent species. Importantly, donors and recipients were unrelated and immunocompetent.

Germ cell transplantation in rodents, and perhaps also cattle, requires that donors and recipients are syngeneic or that recipient animals are immunosuppressed (Kanatsu-Shinohara *et al.*, 2003b; Zhang *et al.*, 2003; Izadyar *et al.*, 2003), whereas germ cell transplantation in pigs and goats was also successful between unrelated individuals (Honaramooz *et al.*, 2002a; Honaramooz *et al.*, 2003a; Honaramooz *et al.*, 2003b). The testis is considered to be an immune-privileged site; however, it is unclear why transplantation between unrelated, immunocompetent animals is possible in domestic animal species, but not in rodents. Nonetheless, this makes the technique infinitely more applicable in nonrodent species.

Xenografting of Testis Tissue

As outlined above, the transplantation of isolated male germ cells represents a very powerful approach for the study of spermatogenesis as well as for the preservation and manipulation of the male germ line. However, the technique cannot be easily adapted between diverse species. Xenogeneic germ cell transplantation does not result in complete sperm production in species other than rodents, probably due to an incompatibility between donor germ cells and recipient Sertoli cells and testicular environment. In contrast, cotransplantation of the donor germ cells with their surrounding testicular tissue into a mouse host preserves the testicular integrity and still allows experimentation in a small rodent. We therefore developed ectopic xenografting of testicular tissue under the back skin of immunodeficient

mice as an alternate approach for the maintenance and propagation of male germ cells that can be more readily applied to different mammalian species (Honaramooz *et al.*, 2002b).

Testis tissue xenografting maintains structural integrity of the testicular tissue, and provides the accessibility essential for the study and manipulation of testis function as well as for male germ line preservation. Through this approach, we showed that xenografting of testis tissue from newborn pigs and goats resulted in the production of normal, functional sperm in a mouse host (Honaramooz *et al.*, 2002b). This was the first report of complete, functional xenogeneic spermatogenesis in species other than rodents, and it also represented the first time that sperm could be obtained from neonatal donors. Subsequently, ectopic xenografting of testicular tissue was also reported from hamsters or marmoset monkeys to mice (Schlatt *et al.*, 2002b).

Similar to isolated germ cells, testicular tissue can be stored frozen prior to grafting and with retention of its developmental potential (Honaramooz *et al.*, 2002b; Schlatt *et al.*, 2002b; Shinohara *et al.*, 2002). Sperm recovered from allografts (mouse) and xenografts (pig, goat) supported pronuclear formation when injected into mouse oocytes. Mouse sperm recovered from allografts resulted in normal, fertile progeny when injected into mouse oocytes followed by embryo transfer (Schlatt *et al.*, 2003). The onset of spermatogenesis in xenografted pig testis tissue occurred slightly earlier than in the donor species (Honaramooz *et al.*, 2002b); and we subsequently demonstrated that testicular maturation and sperm production in rhesus macaques can be significantly accelerated by xenografting of testis tissue, resulting in the production of sperm that support embryo development after injection into rhesus monkey oocytes (Honaramooz *et al.*, 2004).

The accessibility of the tissue in the mouse host makes it possible to manipulate spermatogenesis and steroidogenesis in a controlled manner that is not feasible in the donor animal and certainly not in humans. Xenografting also provides the opportunity to replicate treatments within individual donors, thereby minimizing the effects of individual males on the studied parameter (Rathi *et al.*, 2006). This in turn will allow analysis of the effects of toxicants and potential male contraceptives on testis function in an *in vivo* culture system without extensive experimentation in the target species.

Applications for Transplantation of Germ Cells and Testis Tissue

Germ cell transplantation could serve to restore male fertility after an insult to the testis (Fig. 2). Specifically, one could preserve germ cells prior to irradiation or chemotherapy treatment for cancer, as these treatments often lead to temporary or permanent destruction of spermatogenesis. Reintroduction of autologous germ cells could then restore fertility in the patient once the previous illness has been overcome. This approach was demonstrated in principle in the monkey (Schlatt *et al.*, 2002a) and its application in humans has been discussed (Radford, 2003; Radford *et al.*, 1999), but so far no definitive data has been reported. Reintroduction of donor cells collected before treatment carries the risk that cancerous cells could also be reintroduced into the patient, as demonstrated in leukemic rats (Jahnukainen *et al.*,

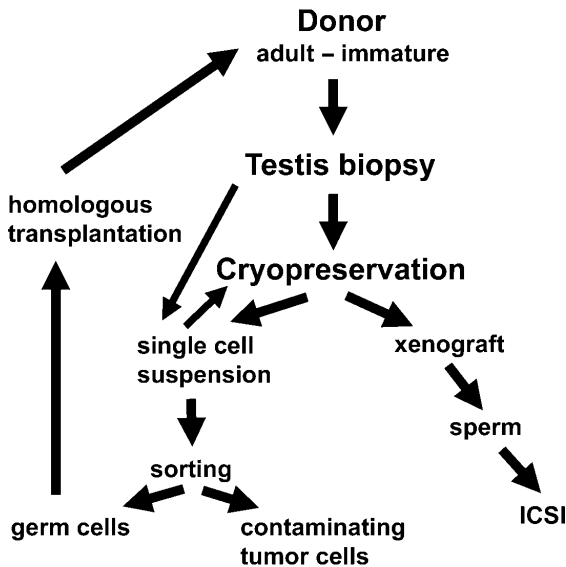

Fig. 2. Illustration of potential application of germ cell transplantation and testis tissue xenografting to the preservation or restoration of donor fertility. Testis tissue collected from an individual donor can be cryopreserved and stored. For homologous germ cell transplantation, a single cell suspension is prepared, either before or after cryostorage. Potential contaminating tumor cells can be removed by cell sorting, and the germ cells can be transplanted back to the donor. Alternatively, testis tissue can be used for xenografting, and the resulting sperm for fertilization by ICSI. Reprinted with permission from Dobrinski (2005).

2001). Cell sorting technology could potentially be employed to overcome this risk (Fujita *et al.*, 2005). Germ cell transplantation has an advantage over the cryopreservation of sperm prior to treatment in that it could be applied to prepubertal males, where sperm cannot be obtained, or to adult males rendered azoospermic or teratozoospermic by the disease. The technique is also of great interest in domestic or endangered animals for its potential to preserve genetic material from immature males that is lost before they reach puberty.

Another important potential application is the transplantation of transfected germ cells as an alternate means to generate transgenic animal models through the manipulation of the male germ line. Although the lack of pure starting populations of germ line stem cells and optimized culture systems together with the low proliferating activity of stem cells have made this a difficult task, some success has been reported in generating transgenic mice and rats by retroviral or lentiviral transduction of germ cells prior to transplantation (Nagano *et al.*, 2000; Nagano *et al.*, 2001a; Nagano *et al.*, 2002b; Hamra *et al.*, 2002; Orwig *et al.*, 2002a). This approach has tremendous potential mainly in species like rats and domestic animals, where embryonic stem cell technology is not available.

Ectopic testis tissue grafting represents a new option for male germ line preservation. As it provides a potentially inexhaustible source of male gametes, even from immature gonads, grafting of fresh or preserved testis tissue offers an invaluable tool for the conservation of fertility by allowing sperm production from immature males. Unlike autologous transplantation of isolated germ cells to restore fertility in a patient following cancer therapy, xenologous grafting and use of the resultant sperm for assisted fertilization would eliminate the potential risk of tumor cell transmission (Fig. 2). However, safety and ethical issues associated with the use of a xenogeneic system would have to be addressed before application to human patients is considered.

Conclusions

Germ cell transplantation and testis tissue xenografting have provided new insights into male germ line stem cell biology and testis function. Transplantation systems can aid in elucidating factors controlling stem cell

proliferation and differentiation as well as aspects of the stem cell niche in the testis. These approaches are also extensively used to study basic biological questions underlying the cause of male infertility. Practical applications are now developed to introduce genetic modifications into the germ line of animals, and to preserve fertility in rare and endangered animals and oncological patients undergoing potentially sterilizing treatments for cancer therapy. The introduction of germ cell transplantation, especially in combination with recent progress in the enrichment and culture of spermatogonial stem cells, has opened up seemingly endless possibilities to study and manipulate male germ line stem cells in mammalian species. It can be expected that the transplantation of germ cells and testis tissue will significantly enhance our understanding of testis function and our ability to control and preserve male fertility.

Acknowledgments

Work from the author's laboratory presented here was supported by 5R01RR017359-04, 1 R21 RR017419-01 (NCRR/NIH), 1R41 HD044780-01 (NICHD/NIH), and USDA/CSREES/NRICGP (2003-35203-13486).

References

- Avarbock, M. R., Brinster, C. J., and Brinster, R. L. (1996). Reconstitution of spermatogenesis from frozen spermatogonial stem cells. *Nat Med* **2**(6), 693–696.
- Boettger-Tong, H., Johnston, D. S., Russell, L. D., Griswold, M. D., and Bishop, C. E. (2000a). Seminiferous tubules from mutant *jsd* (juvenile spermatogonial depletion) mice are capable of supporting transplanted spermatogenesis. *Biol Reprod* **62**(Suppl 1), 108.
- Boettger-Tong, H. L., Johnston, D. S., Russell, L. D., Griswold, M. D., and Bishop, C. E. (2000b). Juvenile spermatogonial depletion (*jsd*) mutant seminiferous tubules are capable of supporting transplanted spermatogenesis. *Biol Reprod* **63**, 1185–1191.
- Brinster, C. J., Ryu, B.-Y., Avarbock, M. R., Karagenc, L., Brinster, R. L., and Orwig, K. E. (2003). Restoration of fertility by germ cell transplantation requires effective recipient preparation. *Biol Reprod* **69**, 412–420.
- Brinster, R. L., and Avarbock, M. R. (1994). Germline transmission of donor haplotype following spermatogonial transplantation. *Proc Natl Acad Sci U S A* **91**, 11303–11307.
- Brinster, R. L., and Zimmermann, J. W. (1994). Spermatogenesis following male germ-cell transplantation. *Proc Natl Acad Sci U S A* **91**, 11298–11302.
- Buaas, F. W., Kirsh, A. L., Sharma, M., McLean, D. J., Morris, J. L., Griswold, M. D., de Rooij, D. G., and Braun, R. E. (2004). Plzf is required in adult male germ cells for stem cell self-renewal. *Nat Genet* **36**, 647–652.

- Bucci, L. R., and Meistrich, M. L. (1987). Effects of busulfan on murine spermatogenesis: cytotoxicity, sterility, sperm abnormalities, and dominant lethal mutations. *Mutat Res* **176**, 259–268.
- Chuma, S., Kanatsu-Shinohara, M., Inoue, K., Ogonuki, N., Miki, H., Toyokuni, S., Hosokawa, M., Nakatsuji, N., Ogura, A., and Shinohara, T. (2005). Spermatogenesis from epiblast and primordial germ cells following transplantation into postnatal mouse testis. *Development* **132**, 117–122.
- Clermont, Y. (1972). Kinetics of spermatogenesis in mammals: seminiferous epithelium cycle and spermatogonial renewal. *Physiol Rev* **52**, 198–236.
- Clouthier, D. E., Avarbock, M. R., Maika, S. D., Hammer, R. E., and Brinster, R. L. (1996). Rat spermatogenesis in mouse testis. *Nature* **381**, 418–421.
- Costoya, J. A., Hobbs, R. M., Barna, M., Cattoretti, G., Manova, K., Sukhwani, M., Orwig, K. E., Wolgemuth, D. J., and Pandolfi, P. P. (2004). Essential role of Plzf in maintenance of spermatogonial stem cells. *Nat Genet* **36**, 653–659.
- Creemers, L. B., Meng, X., den Ouden, K., van Pelt, A. M. M., Izadyar, F., Santoro, M., de Rooij, D. G., and Sariola, H. (2002). Transplantation of germ cells from glial cell line-derived neurotrophic factor-overexpressing mice to host testes depleted of endogenous spermatogenesis by fractionated irradiation. *Biol Reprod* **66**, 1579–1584.
- Dobrinski, I. (2005). Germ cell transplantation. *Semin Reprod Med* **23**, 257–265.
- Dobrinski, I., Avarbock, M. R., and Brinster, R. L. (1999a). Transplantation of germ cells from rabbits and dogs into mouse testes. *Biol Reprod* **61**, 1331–1339.
- Dobrinski, I., Avarbock, M. R., and Brinster, R. L. (2000). Germ cell transplantation from large domestic animals into mouse testes. *Mol Reprod Dev* **57**, 270–279.
- Dobrinski, I., Ogawa, T., Avarbock, M. R., and Brinster, R. L. (1999b). Computer assisted image analysis to assess colonization of recipient seminiferous tubules by spermatogonial stem cells from transgenic donor mice. *Mol Reprod Dev* **53**, 142–148.
- Dobrinski, I., Ogawa, T., Avarbock, M. R., and Brinster, R. L. (2001). Effect of the GnRH-agonist leuprolide on colonization of recipient testes by donor spermatogonial stem cells after transplantation in mice. *Tissue Cell* **33**, 200–207.
- Dyce, P. W., Zhu, H., Craig, J., and Li, J. (2004). Stem cells with multilineage potential derived from porcine skin. *Biochem Biophys Res Commun* **316**, 651–658.
- Feng, L.-X., Chen, Y., Dettin, L., Reijo Pera, R. A., Herr, J. C., Goldberg, E., and Dym, M. (2002). Generation and *in vitro* differentiation of a spermatogonial cell line. *Science* **297**, 392–395.
- Franca, L. R., Ogawa, T., Avarbock, M. R., Brinster, R. L., and Russell, L. D. (1998). Germ cell genotype controls cell cycle during spermatogenesis in the rat. *Biol Reprod* **59**, 1371–1377.
- Fujita, K., Ohta, H., Tsujimura, A., Takao, T., Miyagawa, Y., Takada, S., Matsumiya, K., Wakayama, T., and Okuyama, A. (2005). Transplantation of spermatogonial stem cells isolated from leukemic mice restores fertility without inducing leukemia. *J Clin Invest* **115**, 1855–1861.
- Goossens, E., Frederickx, V., De Block, G., Van Steirteghem, A., and Tournaye, H. (2003). Reproductive capacity of sperm obtained after germ cell transplantation in a mouse model. *Hum Reprod* **18**, 1874–1880.

- Hamra, F. K., Gatlin, J., Chapman, K. M., Grellhesl, D. M., Garcia, J. V., Hammer, R. E., and Garbers, D. L. (2002). Production of transgenic rats by lentiviral transduction of male germ-line stem cells. *Proc Natl Acad Sci U S A* **99**, 14931–14936.
- Hamra, F. K., Schultz, N., Chapman, K. M., Grellhesl, D. M., Cronkhite, J. T., Hammer, R. E., and Garbers, D. L. (2004). Defining the spermatogonial stem cell. *Dev Biol* **269**, 393–410.
- Hofmann, M.-C., Braydich-Stolle, L., Dettin, L., Johnson, E., and Dym, M. (2005). Immortalization of mouse germ line stem cells. *Stem Cells* **23**, 200–210.
- Honaramooz, A., Behboodi, E., Blash, S., Megee, S. O., and Dobrinski, I. (2003a). Germ cell transplantation in goats. *Mol Reprod Dev* **64**, 422–428.
- Honaramooz, A., Behboodi, E., Hausler, C. L., Blash, S., Ayres, S. L., Azuma, C., Echelard, Y., and Dobrinski, I. (2005). Depletion of endogenous germ cells in male pigs and goats in preparation for germ cell transplantation. *J Androl* **26** (in press).
- Honaramooz, A., Behboodi, E., Megee, S. O., Overton, S. A., Galantino-Homer, H. L., Echelard, Y., and Dobrinski, I. (2003b). Fertility and germline transmission of donor haplotype following germ cell transplantation in immunocompetent goats. *Biol Reprod* **69**, 1260–1264.
- Honaramooz, A., Li, M.-W., Penedo, M. C. T., Meyers, S. A., and Dobrinski, I. (2004). Accelerated maturation of primate testis by xenografting into mice. *Biol Reprod* **70**, 1500–1503.
- Honaramooz, A., Megee, S. O., and Dobrinski, I. (2002a). Germ cell transplantation in pigs. *Biol Reprod* **66**, 21–28.
- Honaramooz, A., Snedaker, A., Boiani, M., Scholer, H. R., Dobrinski, I., and Schlatt, S. (2002b). Sperm from neonatal mammalian testes grafted in mice. *Nature* **418**, 778–781.
- Huckins, C. (1971). Spermatogonial stem cell population in adult rats. I. Their morphology, proliferation and maturation. *Anat Rec* **169**, 533–558.
- Izadyar, F., den Ouden, K., Stout, T. A. E., Stout, J., Coret, J., Lankveld, D. P. K., Spoormakers, T. J. P., Colenbrander, B., Oldenbroek, J. K., van der Ploeg, K. D., Woelders, H., Kal, H. B., and de Rooij, D. G. (2003). Autologous and homologous transplantation of bovine spermatogonial stem cells. *Reproduction* **126**, 765–774.
- Izadyar, F., Spierenberg, G. T., Creemers, L. B., den Ouden, K., and de Rooij, D. G. (2002). Isolation and purification of type A spermatogonia from the bovine testis. *Reproduction* **124**, 85–94.
- Jahnukainen, K., Hou, M., Petersen, C., Setchell, B., and Soder, O. (2001). Intratesticular transplantation of testicular cells from leukemic rats causes transmission of leukemia. *Cancer Res* **61**, 706–710.
- Jeong, D., McLean, D. J., and Griswold, M. D. (2003). Long-term culture and transplantation of murine testicular germ cells. *J Androl* **24**, 661–669.
- Jiang, F.-X., and Short, R. V. (1995). Male germ cell transplantation in rats: apparent synchronization of spermatogenesis between host and donor seminiferous epithelia. *Int J Androl* **18**, 326–330.
- Johnston, D. S., Russell, L. D., Friel, P. J., and Griswold, M. D. (2001). Murine germ cells do not require functional androgen receptors to complete spermatogenesis following spermatogonial stem cell transplantation. *Endocrinology* **142**, 2405–2408.
- Kanatsu-Shinohara, M., Inoue, K., Lee, J., Yoshimoto, M., Ogonuki, N., Miki, H., Baba, S., Kato, T., Kazuki, Y., Toyokuni, S., Toyoshima, M., Niwa, O., Oshimura, M., Heike, T.,

- Nakahata, T., Ishino, F., Ogura, A., and Shinohara, T. (2004a). Generation of pluripotent stem cells from neonatal mouse testis. *Cell* **119**, 1001–1012.
- Kanatsu-Shinohara, M., Miki, H., Inoue, K., Ogonuki, N., Toyokuni, S., Ogura, A., and Shinohara, T. (2005). Long-term culture of mouse male germline stem cells under serum- or feeder-free conditions. *Biol Reprod* **72**, 985–991.
- Kanatsu-Shinohara, M., Ogonuki, N., Inoue, K., Miki, H., Ogura, A., Toyokuni, S., and Shinohara, T. (2003a). Long-term proliferation in culture and germline transmission of mouse male germline stem cells. *Biol Reprod* **69**, 612–616.
- Kanatsu-Shinohara, M., Ogonuki, N., Inoue, K., Ogura, A., Toyokuni, S., Honjo, T., and Shinohara, T. (2003b). Allogeneic offspring produced by male germ line stem cell transplantation into infertile mouse testis. *Biol Reprod* **68**, 167–173.
- Kanatsu-Shinohara, M., Toyokuni, S., Morimoto, T., Matsui, S., Honjo, T., and Shinohara, T. (2003c). Functional assessment of self-renewal activity of male germline stem cells following cytotoxic damage and serial transplantation. *Biol Reprod* **68**, 1801–1807.
- Kanatsu-Shinohara, M., Toyokuni, S., and Shinohara, T. (2004b). CD9 is a surface marker on mouse and rat male germline stem cells. *Biol Reprod* **70**, 70–75.
- Kangasniemi, M., Wilson, G., Parchuri, N., Huhtaniemi, I., and Meistrich, M. L. (1995). Rapid protection of rat spermatogenic stem cells against procarbazine by treatment with a gonadotropin-releasing hormone antagonist (Nal-Glu) and an antiandrogen (flutamide). *Endocrinology* **136**, 2881–2888.
- Kubota, H., Avarbock, M. R., and Brinster, R. L. (2003). Spermatogonial stem cells share some, but not all, phenotypic and functional characteristics with other stem cells. *Proc Natl Acad Sci U S A* **100**, 6487–6492.
- Kubota, H., Avarbock, M. R., and Brinster, R. L. (2004a). Culture conditions and single growth factors affect fate determination of mouse spermatogonial stem cells. *Biol Reprod* **71**, 722–731.
- Kubota, H., Avarbock, M. R., and Brinster, R. L. (2004b). Growth factors essential for self-renewal and expansion of mouse spermatogonial stem cells. *Proc Natl Acad Sci U S A* **101**, 16489–16494.
- Kues, W. A., Petersen, B., Mysegades, W., Carnwath, J. W., and Niemann, H. (2005). Isolation of murine and porcine fetal stem cells from somatic tissue. *Biol Reprod* **72**, 1020–1028.
- Lassalle, B., Bastos, H., Louis, J. P., Testart, J., Dutrillaux, B., Fouchet, P., and Allemand, I. (2004). ‘Side population’ cells in adult mouse testis express Bcrp1 gene and are enriched in spermatogonia and germinal stem cells. *Development* **131**, 479–487.
- Mahato, D., Goulding, E. H., Korach, K. S., and Eddy, E. M. (2000). Spermatogenic cells do not require estrogen receptor- α for development or function. *Endocrinology* **141**, 1273–1276.
- Meistrich, M. L., and van Beek, M. E. A. B. (1993). Spermatogonial stem cells: assessing their survival and ability to produce differentiated cells. In: *Methods in Toxicology*, Vol. 3A, R. E. Chapin & J. Heindel, eds., Academic Press, New York, pp. 106–123.
- Nagano, M. (2003). Homing efficiency and proliferation kinetics of male germ line stem cells following transplantation in mice. *Biol Reprod* **69**, 701–707.
- Nagano, M., Avarbock, M. R., and Brinster, R. L. (1999). Pattern and kinetics of mouse donor spermatogonial stem cell colonization in recipient testes. *Biol Reprod* **60**, 1429–1436.

- Nagano, M., Avarbock, M. R., Leonida, E. B., Brinster, C. J., and Brinster, R. L. (1998). Culture of mouse spermatogonial stem cells. *Tissue Cell* **30**, 389–397.
- Nagano, M., Brinster, C. J., Orwig, K. E., Ryu, B.-Y., Avarbock, M. R., and Brinster, R. L. (2001a). Transgenic mice produced by retroviral transduction of male germ-line stem cells. *Proc Natl Acad Sci U S A* **98**, 13090–13095.
- Nagano, M., McCarrey, J. R., and Brinster, R. L. (2001b). Primate spermatogonial stem cells colonize mouse testes. *Biol Reprod* **64**, 1409–1416.
- Nagano, M., Patrizio, P., and Brinster, R. L. (2002a). Long-term survival of human spermatogonial stem cells in mouse testes. *Fertil Steril* **78**, 1225–1233.
- Nagano, M., Ryu, B.-Y., Brinster, C. J., Avarbock, M. R., and Brinster, R. L. (2003). Maintenance of mouse male germ line stem cells in vitro. *Biol Reprod* **68**, 2207–2214.
- Nagano, M., Shinohara, T., Avarbock, M. R., and Brinster, R. L. (2000). Retrovirus-mediated gene delivery into male germ line stem cells. *FEBS Lett* **475**, 7–10.
- Nagano, M., Watson, D. J., Ryu, B.-Y., Wolfe, J. H., and Brinster, R. L. (2002b). Lentiviral vector transduction of male germ line stem cells in mice. *FEBS Lett* **524**, 111–115.
- Noguchi, J., Toyama, Y., Yuasa, S., Kikuchi, K., and Kaneko, M. (2002). Hereditary defects in both germ cells and the blood-testis barrier system in as-mutant rats: evidence from spermatogonial transplantation and tracer-permeability analysis. *Biol Reprod* **67**, 880–888.
- Ogawa, T., Arechaga, J. M., Avarbock, M. R., and Brinster, R. L. (1997). Transplantation of testis germinal cells into mouse seminiferous tubules. *Int J Dev Biol* **41**, 111–122.
- Ogawa, T., Dobrinski, I., Avarbock, M. R., and Brinster, R. L. (1998). Leuprolide, a gonadotropin-releasing hormone agonist, enhances colonization after spermatogonial transplantation into mouse testes. *Tissue Cell* **30**, 583–588.
- Ogawa, T., Dobrinski, I., Avarbock, M. R., and Brinster, R. L. (1999a). Xenogeneic spermatogenesis following transplantation of hamster germ cells to mouse testes. *Biol Reprod* **60**, 515–521.
- Ogawa, T., Dobrinski, I., Avarbock, M. R., and Brinster, R. L. (2000). Transplantation of male germ line stem cells restores fertility in infertile mice. *Nat Med* **6**, 29–34.
- Ogawa, T., Dobrinski, I., and Brinster, R. L. (1999b). Recipient preparation is critical for spermatogonial transplantation in the rat. *Tissue Cell* **31**, 461–472.
- Ogawa, T., Ohmura, M., Yumura, Y., Sawada, H., and Kubota, Y. (2003). Expansion of murine spermatogonial stem cells through serial transplantation. *Biol Reprod* **68**, 316–322.
- Ohmura, M., Ogawa, T., Ono, M., Dezawa, M., Hosaka, M., Kubota, Y., and Sawada, H. (2003). Increment of murine spermatogonial cell number by gonadotropin-releasing hormone analogue is independent of stem cell factor c-kit signal. *Biol Reprod* **68**, 2304–2313.
- Ohta, H., Yomogida, K., Dohmae, K., and Nishimune, Y. (2000). Regulation of proliferation and differentiation in spermatogonial stem cells: the role of c-kit and its ligand SCF. *Development* **127**, 2125–2131.
- Ohta, H., Yomogida, K., Tadokoro, Y., Tohda, A., Dohmae, K., and Nishimune, Y. (2001). Defect in germ cells, not supporting cells, is the cause of male infertility in the jsd mutant mouse: proliferation of spermatogonial stem cells without differentiation. *Int J Androl* **24**, 15–23.

- Orwig, K. E., Avarbock, M. R., and Brinster, R. L. (2002a). Retrovirus-mediated modification of male germline stem cells in rats. *Biol Reprod* **67**, 874–879.
- Orwig, K. E., Shinohara, T., Avarbock, M. R., and Brinster, R. L. (2002b). Functional analysis of stem cells in the adult rat testis. *Biol Reprod* **66**, 944–949.
- Parreira, G. C., Ogawa, T., Avarbock, M. R., Franca, L. R., Brinster, R. L., and Russell, L. D. (1998). Development of germ cell transplants in mice. *Biol Reprod* **59**, 1360–1370.
- Radford, J. (2003). Restoration of fertility after treatment for cancer. *Horm Res* **59**, 21–23.
- Radford, J. A., Shalet, S. M., and Lieberman, B. A. (1999). Fertility after treatment for cancer. *Br Med J* **319**, 935–936.
- Rathi, R., Honaramooz, A., Zeng, W., Schlatt, S., and Dobrinski, I. (2006). Germ cell fate and seminiferous tubule development in bovine testis xenografts. *Reproduction* (in press).
- Rilianawati, Speed, R., Taggart, M., and Cooke, H. J. (2003). Spermatogenesis in testes of *Dazl* null mice after transplantation of wild-type germ cells. *Reproduction* **126**, 599–604.
- Russell, L. D., Ettlin, R. A., SinhaHikim, A. P., and Clegg, E. D. (1990). Mammalian spermatogenesis. In: *Histological and Histopathological Evaluation of the Testis*, L. D. Russell, R. A. Ettlin, A. P. SinhaHikim, and E. D. Clegg, eds., Cache River Press, Clearwater, FL, pp. 1–40.
- Ryu, B.-Y., Orwig, K. E., Avarbock, M. R., and Brinster, R. L. (2003). Stem cell and niche development in the postnatal rat testis. *Dev Biol* **263**, 253–263.
- Ryu, B.-Y., Orwig, K. E., Kubota, H., Avarbock, M. R., and Brinster, R. L. (2004). Phenotypic and functional characteristics of spermatogonial stem cells in rats. *Dev Biol* **274**, 158–170.
- Schlatt, S., Foppiani, L., Rolf, C., Weinbauer, G. F., and Nieschlag, E. (2002a). Germ cell transplantation into X-irradiated monkey testes. *Hum Reprod* **17**, 55–62.
- Schlatt, S., Honaramooz, A., Boiani, M., Scholer, H. R., and Dobrinski, I. (2003). Progeny from sperm obtained after ectopic grafting of neonatal mouse testes. *Biol Reprod* **68**, 2331–2335.
- Schlatt, S., Kim, S. S., and Gosden, R. (2002b). Spermatogenesis and steroidogenesis in mouse, hamster and monkey testicular tissue after cryopreservation and heterotopic grafting to castrated hosts. *Reproduction* **124**, 339–346.
- Shinohara, T., Avarbock, M. R., and Brinster, R. L. (1999). β_1 - and α_6 -integrin are surface markers on mouse spermatogonial stem cells. *Proc Natl Acad Sci U S A* **96**, 5504–5509.
- Shinohara, T., Avarbock, M. R., and Brinster, R. L. (2000a). Functional analysis of spermatogonial stem cells in Steel and cryptorchid infertile mouse models. *Dev Biol* **220**, 401–411.
- Shinohara, T., Inoue, K., Ogonuki, N., Kanatsu-Shinohara, M., Miki, H., Nakata, K., Kurome, M., Nagashima, H., Toyokuni, S., Kogishi, K., Honjo, T., and Ogura, A. (2002). Birth of offspring following transplantation of cryopreserved immature testicular pieces and in-vitro microinsemination. *Hum Reprod* **17**, 3039–3045.
- Shinohara, T., Orwig, K. E., Avarbock, M. R., and Brinster, R. L. (2000b). Spermatogonial stem cell enrichment by multiparameter selection of mouse testis cells. *Proc Natl Acad Sci U S A* **97**, 8346–8351.
- Shinohara, T., Orwig, K. E., Avarbock, M. R., and Brinster, R. L. (2001). Remodeling of the postnatal mouse testis is accompanied by dramatic changes in stem cell number and niche accessibility. *Proc Natl Acad Sci U S A* **98**, 6186–6191.

- Shinohara, T., Orwig, K. E., Avarbock, M. R., and Brinster, R. L. (2003). Restoration of spermatogenesis in infertile mice by Sertoli cell transplantation. *Biol Reprod* **68**, 1064–1071.
- Tegelenbosch, R. A. J., and de Rooij, D. G. (1993). A quantitative study of spermatogonial multiplication and stem cell renewal in the C3H/101 F₁ hybrid mouse. *Mutat Res* **290**, 193–200.
- van Pelt, A. M. M., Roepers-Gajadien, H. L., Gademan, I. S., Creemers, L. B., de Rooij, D. G., and van Dissel-Emiliani, F. M. F. (2002). Establishment of cell lines with rat spermatogonial stem cell characteristics. *Endocrinology* **143**, 1845–1850.
- Vecino, P., Uranga, J. A., and Arechaga, J. (2001). Suppression of spermatogenesis for cell transplantation in adult mice. *Protoplasma* **217**, 191–198.
- Ventela, S., Ohta, H., Parvinen, M., and Nishimune, Y. (2002). Development of stages of the cycle in mouse seminiferous epithelium after transplantation of green fluorescent protein-labeled spermatogonial stem cells. *Biol Reprod* **66**, 1422–1429.
- Wistuba, J., Schlatt, S., Cantauw, C., von Schonfeldt, V., Nieschlag, E., and Behr, R. (2002). Transplantation of wild-type spermatogonia leads to complete spermatogenesis in testes of cyclic 3',5'-adenosine monophosphate response element modulator-deficient mice. *Biol Reprod* **67**, 1052–1057.
- Yomogida, K., Yagura, Y., Tadokoro, Y., and Nishimune, Y. (2003). Dramatic expansion of germinal stem cells by ectopically expressed human glial cell line-derived neurotrophic factor in mouse Sertoli cells. *Biol Reprod* **69**, 1303–1307.
- Zambrowicz, B. P., Imamoto, A., Fiering, S., Herzenberg, L. A., Kerr, W. G., and Soriano, P. (1997). Disruption of overlapping transcripts in the ROSA β geo 26 gene trap strain leads to widespread expression of β -galactosidase in mouse embryos and hematopoietic cells. *Proc Natl Acad Sci U S A* **94**, 3789–3794.
- Zhang, Z., Renfree, M. B., and Short, R. V. (2003). Successful intra- and interspecific male germ cell transplantation in the rat. *Biol Reprod* **68**, 961–967.

CHAPTER 12

ORTHODOX AND UNORTHODOX WAYS TO INITIATE FERTILIZATION AND DEVELOPMENT IN MAMMALS

Ryuzo Yanagimachi

*Institute for Biogenesis Research,
John A. Burns School of Medicine,
University of Hawaii,
Honolulu, Hawaii 96822 USA*

The essence of fertilization is the mingling of female and male genomes to create a new individual with a genomic combination that never existed before. In the female germ cell, the plasma membrane becomes fusion-competent first, and then maturation of the cytoplasm and nucleus follows. This order of maturation is reversed in the male germ cell: the male germ cell completes first its nuclear maturation, then its cytoplasmic maturation; the plasma membrane becomes fusion-competent last. The nuclei of polar bodies can be used as substitutes for female pronuclei to produce live offspring. At least in the mouse, the nuclei of spermatocytes can participate in embryo development after completion of meiosis within the oocytes. The nuclei of deformed spermatozoa can participate in embryo development as long as they are genomically normal. By ICSI, men with defective Y chromosomes transmit their infertility to their sons, but not to their daughters. In the future, it may be possible for defective Y chromosomes in spermatozoa and prespermatozoal cells to be repaired or replaced by the normal Y chromosomes of other individuals. Cloning using adult somatic cells is an entirely new reproduction method. Its efficiency is rather low at present, regardless of the species and cell types tested. In the future, cloning may become as efficient as natural reproduction, but exclusive use of cloning would not benefit long-term survival of the species.

Keywords: Fertilization; sperm; oocyte; IVF; ICSI; ROSI; cloning.

Introduction

The essence of fertilization is the mingling of genes via the union of germ cells from the female (oocytes) and the male (spermatozoa). Each of the

Corresponding author: Ryuzo Yanagimachi; e-mail: yana@hawaii.edu

resulting zygotes has a new combination of genes that did not exist before. This genetic diversity among all individuals is important for the survival and continuation of the species. Sudden changes in the physical and biological environments as well as serious contagious diseases could destroy the entire population of species, if it consists of individuals with identical or similar genomic constitutions.

Preparation of Germ Cells for Fertilization

All cells, including germ cells, have three major components: the plasma membrane, cytoplasm, and nucleus. In the female germ cell, the plasma membrane becomes fusion-competent first, and then maturation of the cytoplasm and the nucleus follows. The order of maturation is reversed in the male germ cell (Fig. 1). While mammalian female germ cells become fertilization-competent during the progression of meiosis, male germ cells

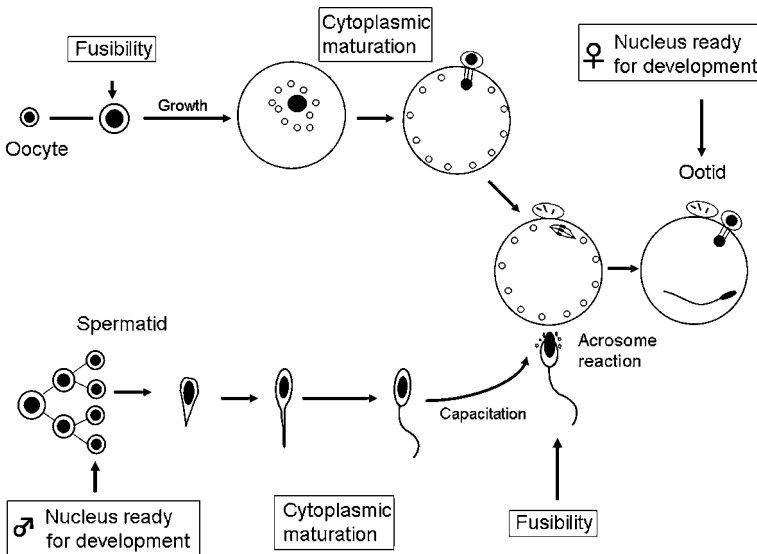

Fig. 1. Preparations of female and male germ cells for fertilization. In the female germ cell, the plasma membrane first becomes competent to fuse with male germ cells, the cytoplasm matures, then the nucleus becomes ready to unite with the nucleus of the male germ cell for embryonic development. In the male germ cell, on the contrary, the nucleus first becomes ready for development, the cytoplasm matures, then the plasma membrane becomes fusion-competent.

do not, even after the completion of meiosis. Haploid male germ cells must undergo drastic structural and physiological modifications before they become fertilization-competent. These postmeiotic changes include spermiogenesis (in the testis), maturation (in the epididymis), capacitation (in the female tract), and acrosome reaction (near/on the female germ cells). Such extra modifications must have evolved as the processes dedicated to the delivery of the male's haploid nuclei into the female germ cells.

Mature female germ cells, the oocytes, are surrounded by noncellular coats that protect developing embryos from physical damage, infection, and predation. In some invertebrates, distinct coats may not be seen on individual oocytes before fertilization, but may appear after fertilization. In all animals, the coats, thin or thick, are essential to maintain the genetic individuality of each embryo during the early stages of development (Yanagimachi, 1998).

Assisted Fertilization

In vitro fertilization (IVF) is a powerful tool, and perhaps the only one, to analyze the processes and mechanisms of mammalian fertilization. In humans, IVF was first developed as a means of overcoming female infertility due to oviduct occlusion. Since then, IVF procedures have been greatly improved, but we cannot be too cautious about the way we handle gametes and embryos *in vitro* because their exposure to suboptimal conditions may result in offspring with aberrant gene expression (Ecker *et al.*, 2004; Fernandez-Gonzalez *et al.*, 2004).

Intracytoplasmic sperm injection (ICSI) is the microsurgical insertion of a single spermatozoon into an oocyte. Unlike IVF, ICSI requires only one genetically normal spermatozoon to generate one healthy offspring. Spermatozoa that appear abnormal are not necessarily genomically abnormal, just as spermatozoa that appear normal are not necessarily genomically normal. However, the incidence of genomically abnormal spermatozoa is higher among spermatozoa that appear abnormal (Yanagimachi, 2005). Although it may become possible for genomically normal spermatozoa and oocytes to be identified prior to assisted fertilization without using invasive methods, genetic preimplantation diagnosis is thus far the only way to distinguish genetically and epigenetically normal embryos from abnormal embryos.

For animal ICSI, spermatozoa do not need to be alive. For example, freeze-dried mouse spermatozoa are dead in the conventional sense. Their plasma membranes are broken and they are totally infertile under ordinary conditions. Nevertheless, these spermatozoa can produce perfectly normal offspring by ICSI, even after they are shipped outside of the United States at ambient temperatures (Yanagimachi, 2005). Irrespective of number, morphology, and motility, as long as the spermatozoa are genomically normal, they can produce normal offspring.

ICSI can rescue infertility in males without transmitting infertility to the next generation. If a dominant infertility gene is involved, however, transmission could occur. If defective Y chromosomes are responsible, ICSI will definitely transmit infertility to sons, but not to daughters. In the future, it may be possible for defective Y chromosomes in spermatozoa or prespermatozoal cells to be “repaired” or replaced by normal Y chromosomes from other individuals (Fig. 2).

Common laboratory rodents, such as mice, do not require sperm centrosomes for normal fertilization. In most animals, including humans, the sperm’s proximal centrosome becomes the center of the microtubular aster, which brings sperm and oocyte pronuclei to the center of the zygote (Schatten, 1994). Sperm centrosomes *per se*, however, may not be essential for embryo development because porcine oocytes injected with isolated sperm heads (without proximal centrosomes) can develop normally, at least to the blastocyst stage (Kim *et al.*, 1998). Pigs cloned from somatic cells (Polejaeva *et al.*, 2000; Lai and Prather, 2003) must have had centrosomes of donor cells used for the initiation of their development.

A normal spermatozoon carries a factor (or factors) that activates the oocyte. At least in rodents, this sperm-borne oocyte-activating factor (SOAF) resides in the sperm head because an isolated head without plasma membrane can activate an oocyte by ICSI as effectively as can an intact spermatozoon. The most promising candidate thus far for SOAF is phospholipase C zeta (Parrington *et al.*, 1998; Swann *et al.*, 2004). The spermatozoa of some infertile male humans and animals lack or are deficient in SOAF. Oocytes injected with such spermatozoa remain unactivated, with sperm heads (nuclei) transforming into prematurely condensed chromosomes. Such oocytes must be artificially activated immediately after

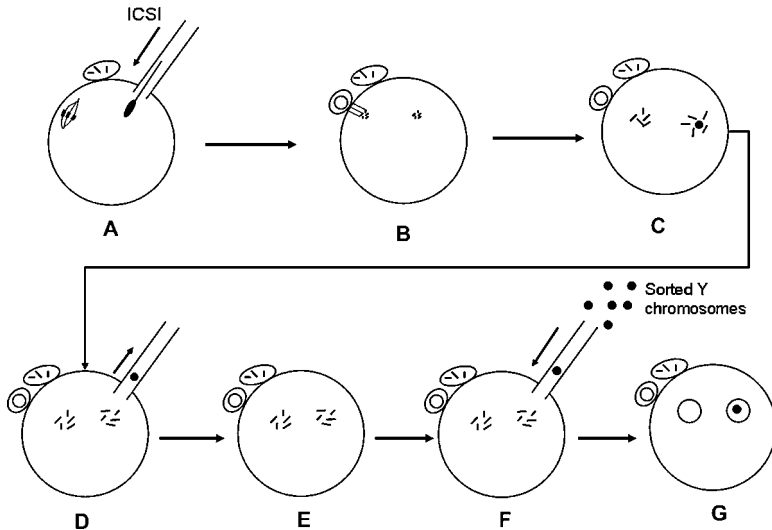

Fig. 2. Hypothetical scheme of replacing “defective” Y chromosome with normal one. **A.** Inject a single spermatozoon of a man with defective Y chromosome into an oocyte. **B–C.** An activated oocyte extrudes the second polar body. Oocyte and sperm chromosomes appear. Y chromosome-specific fluorescence probe can be used to indicate the Y chromosome. **D–E.** Remove Y chromosome microsurgically. Pretreatment of oocytes with microtubule-disrupting reagent would enhance the surgery. **F.** Chromosomes of a man with normal Y chromosome are sorted by the chromosome sorter, and a single Y chromosome is injected near sperm chromosomes. **G.** An oocyte receiving normal Y chromosome will develop into a fertile male with normal Y chromosome.

ICSI to produce healthy offspring. Postovulatory aging of oocytes must be minimized.

Round spermatids with a haploid set of chromosomes can be used as substitutes for spermatozoa to produce live offspring, at least in laboratory rodents. Round spermatid injection (ROSI), which refers to the injection of a single round spermatid nucleus into an oocyte, has been successful in mice and several other animals (Yanagimachi, 2005). Round spermatids may or may not have enough SOAF, depending on the species. Since mouse round spermatids can hardly activate oocytes, ROSI oocytes must be artificially activated. Although chemical or physical stimuli work rather well, injection of the “native” SOAF would be ideal. The nuclei of the primary and secondary spermatocytes (of the mouse) can undergo meiosis after injection into maturing or mature oocytes. Live offspring were obtained by using

haploid nuclei thus obtained, but efficiency was less compared with the use of ICSI and ROSI (Yanagimachi, 2005).

Normally, a single oocyte produces a single offspring. However, four offspring can be produced using chromosomes in a single maturing oocyte by saving the first and second polar bodies (Fig. 3) (Wakayama and Yanagimachi, 1998).

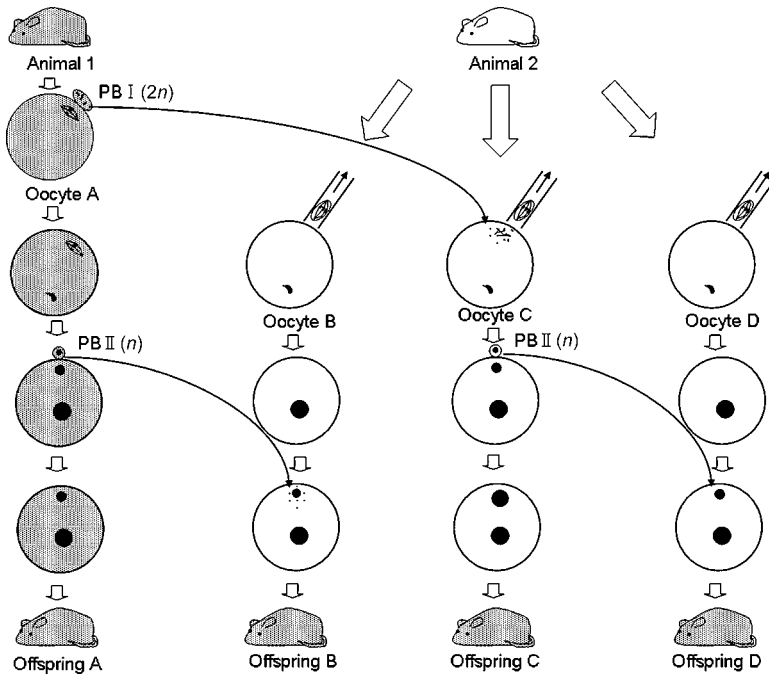

Fig. 3. A diagram illustrating the possible production of four offspring using chromosomes of a single oocyte. The first polar body (PB) of oocyte A from animal 1 (shaded) is transferred into oocyte C from animal 2 (albino), which has been enucleated. In this diagram, the number ($2n$, n) refers to ploidy of chromosomes rather than centromere number *per se*. After the first polar body chromosomes (PB I) transform into metaphase chromosomes, a single sperm head is injected. This oocyte is activated to form two pronuclei and the second polar body (PB II). It eventually develops into offspring C. Oocyte D is first enucleated and then injected with a single sperm head. After the sperm head transforms into a pronucleus in the activated oocyte, the nucleus of the second polar body from oocyte C is transferred into oocyte D. This oocyte develops into offspring D. Offspring A develops from oocyte A of animal 1. Offspring B is produced by transferring the nucleus of the second polar body of oocyte A into oocyte B with sperm pronucleus only. Modified from Wakayama and Yanagimachi (1998).

Cloning

The most unorthodox method of reproduction is cloning using the nuclei of adult somatic cells. Although cloning is possible in various species using different types of cells, its overall efficiency (the proportion of live offspring developed from all nuclear-transferred oocytes) is only a few percent or less, irrespective of species and type of cells used. Some researchers reported very high success rates with this method, but it is not certain whether such high rates were consistent. Most cloned embryos stop development before implantation or during organogenesis. Death in newborns and young animals shortly after birth is common (Inui, 2005). Thus, the birth of “perfectly healthy” offspring is the exception rather than the rule. Although some cloned animals have a normal life span (Sakai *et al.*, 2005), others die prematurely due to various health problems (Chavatte-Palmer *et al.*, 2002) that seem to be largely epigenetic rather than genetic, because offspring produced by mating between cloned females and cloned males are free of development and health problems. In the future, cloning may become as efficient as natural reproduction, but exclusive use of cloning would not benefit long-term survival of the species.

References

- Chavatte-Palmer, P., Heyman, Y., Richard, C., Monget, P., LeBourhis, D., Kann, G., Chillard, Y., Vignon, X., and Renard, J. P. (2002). Clinical, hormonal, and hematologic characteristics of bovine calves derived from nuclei from somatic cells. *Biol Reprod* **66**, 1596–1603.
- Ecker, D. J., Stein, O., Xu, Z., Kopf, G. S., Bilker, W. B., Abel, T., and Shultz, R. M. (2004). Long-term effects of culture of preimplantation mouse embryos on behavior. *Proc Natl Acad Sci U S A* **101**, 1595–1600.
- Fernandez-Gonzalez, R., Moireira, P., Bilbao, A., Jimenez, A., Perez-Crespo, M., Ramirez, M., De Fonseca, F. R., Pintado, B., and Gutierrez-Adan, A. (2004). Long-term effect of in vitro culture of mouse embryos with serum on mRNA expression of imprinted genes, development, and behavior. *Proc Natl Acad Sci U S A* **101**, 5880–5885.
- Inui, A. (2005). *Epigenetic Risks of Cloning*, Taylor & Francis Group, Boca Raton, FL.
- Kim, N. H., Lee, J. W., Jun, S. H., Lee, H. T., and Chung, K. S. (1998). Fertilization of porcine oocytes following intracytoplasmic spermatozoon or isolated sperm head injection. *Mol Reprod Dev* **51**, 436–444.
- Lai, L., and Prather, R. S. (2003). Creating genetically modified pigs by using nuclear transfer. *Reprod Biol Endocrinol* **7**, 82. Published online.
- Parrington, J., Lai, F. A., and Swann, K. (1998). A novel protein for Ca²⁺ signaling at fertilization. *Curr Top Dev Biol* **39**, 215–243.

- Polejaeva, I. A., Chen, S. H., Vaught, T. D., Page, R. L., Mullins, J., Ball, S., Dai, Y., Boone, J., Walker, S., Ayares, D. L., Colman, A. A., and Campbell, K. H. (2000). Cloned pigs by nuclear transfer from adult somatic cells. *Nature* **27**, 29–30.
- Sakai, R. R., Tamashiro, K. L., Yamazaki, Y., and Yanagimachi, R. (2005). Cloning and assisted reproductive techniques: influence on early development and adult phenotype. *Birth Defects Res C Embryo Today* **75**, 151–162.
- Schatten, G. (1994). The centrosome and its mode of inheritance: the reduction of the centrosome during gametogenesis and its restoration during fertilization. *Dev Biol* **165**, 299–335.
- Swann, K., Larman, M. G., Saunders, C. M., and Lai, F. A. (2004). The cytosolic sperm factor that triggers Ca^{2+} oscillations and egg activation in mammals is a novel phospholipase C: PLCzeta. *Reproduction* **127**, 431–439.
- Wakayama, T., and Yanagimachi, R. (1998). The first polar body can be used for the production of normal offspring in mice. *Biol Reprod* **59**, 100–104.
- Yanagimachi, R. (1998). Roles of egg coats in reproduction: an overview. *Zygote* **6**, S1–S3.
- Yanagimachi, R. (2005). Intracytoplasmic injection of spermatozoa and spermatogenic cells: its biology and applications in humans and animals. *Reprod Biomed Online* **10**, 247–288.

CHAPTER 13

PATHOGENESIS OF TESTICULAR GERM CELL TUMORS

Leendert H. J. Looijenga

*Department of Pathology,
Erasmus MC–University Medical Center Rotterdam,
Daniel den Hoed Cancer Center,
Josephine Nefkens Institute,
The Netherlands*

Recently, we proposed that human germ cell tumors (GCTs) can be classified into five entities, each characterized by histology, clinical behavior, age of the patient at clinical presentation, and genomic constitution. Within the testis, three of these entities can be found: type I GCTs (teratomas and yolk sac tumors of neonates and infants), type II GCTs (seminomatous and nonseminomatous tumors of adolescents and young adults), and type III GCTs (spermatocytic seminomas). These three types of GCTs each represents a specific stage of normal germ cell development, for which knowledge has revealed the identification of informative markers for (early) diagnosis. Moreover, this difference in origin most likely also explains their characteristic variation in developmental potential of the tumors, i.e. the capacity to form the different lineages of differentiation. This is nicely illustrated by the value of the markers PLAP, c-KIT, and more recently OCT3/4-POU5F1 for the seminomatous and undifferentiated cell type of nonseminomatous tumors (embryonal carcinoma); and XPA, SCP1, and SSX for spermatocytic seminomas. The seminomas and nonseminomas originate from a transformed primordial germ cell/gonocyte — known as carcinoma *in situ* (CIS)/intratubular germ cell neoplasia, unclassified (ITGCNU) — representing an erased germ cell. The derived tumors are indeed omnipotent, as recently shown by the possible generation of the germ cell lineage within the tumor itself. In contrast, the spermatocytic seminoma represents a spermatocyte (a more mature germ cell of the spermatogenic lineage), which has already undergone partial paternal imprinting. This tumor is highly restricted in its developmental potential. Type I GCTs most likely originate from a partially erased embryonic germ cell. The three types of germ cell tumors have different pathogeneses, related to different risk factors and genomic changes.

The latter are diagnostic on their own, but also facilitate identification of the gene or genes involved in the genesis of the cancer. While type I teratomas do not show genomic imbalances, type I yolk sac tumors show consistent genomic changes, including loss of 1p, 4, and 6q, and gain of 1q and 20q. Type II GCTs (including the teratomas) are always aneuploid with loss of 4, 5, 11, 13, 18, and Y, and gain of 7, 8, 12p, and X as recurrent anomalies. While all invasive type II GCTs show additional copies of the short arm of chromosome 12, this is not consistently found in CIS/ITGCNU and is therefore progression-related. The tumor cells of spermatocytic seminomas typically have a diploid, a tetraploid, and a hypertetraploid DNA content. In addition, gain of chromosome 9 is the only consistent anomaly found so far.

Keywords: Teratoma; yolk sac tumor; seminoma; nonseminoma; spermatocytic seminoma; pathogenesis.

Introduction

Germ cell tumors (GCTs) have been regarded as complex because of their variety of histological representations. This is, however, expected based on their origin, being a germ cell that might be omnipotent depending on its stage of maturation (Donovan and de Miguel, 2003). In spite of this supposed heterogeneity in developmental potential, through careful investigation of different sets of data from the various types of GCTs, a number of specific entities that are relevant from different points of view emerge (Oosterhuis and Looijenga, 2005). Here, I will focus on the three entities of GCTs that exist within the human testis (see Table 1).

With the exception of the spermatocytic seminomas (which we refer to as type III GCTs), the other two groups (types I and II) can be found at different anatomical localizations, predominantly along the midline of the body. Although these extragonadal GCTs will not be discussed here, they are of interest because their similarities with those found in the testis might shed light on their origin and pathogenesis. An interesting and relevant recent finding in this context is the observation that (female) germ cells can be derived *in vivo* from cells present in bone marrow or peripheral blood (Johnson *et al.*, 2005). This might explain the occurrence of extragonadal GCTs, although they might also be derived from (mis)migrated and/or (mis)survived germ cells during their migration from the yolk sac to the genital ridge (Stallock *et al.*, 2003).

Table 1. Classification of human germ cell tumors, based on epidemiology, histology, clinical behavior, and chromosomal constitution.

Type	Histology	Age	Precursor (imprinting)	Site	Genome
I	Teratoma & yolk sac tumor	Neonates & infants	Embryonic germ cell (partially erased)	Brain, neck, sacrum, testis, ovary	Diploid & aneuploid (gain: 1q,20q; loss: 1p,4,6q)
II	Seminomatous and nonseminomatous tumors	Adolescents and young adults	Primordial germ cell/gonocyte (erased)	Brain, mediastinum, testis, ovary, dysgenetic gonads	Aneuploid (gain: 7,8,12p,X; loss: 4,5,11,13,Y)
III	Spermatocytic seminoma	Elderly	Spermatocyte (partially paternally imprinted)	Testis	Diploid, tetraploid, hypertetraploid (gain: 9)

Classification of Human GCTs: Limitations and Possibilities

The traditional classification system from a pathologist's point of view divides (testicular) GCTs based purely on their histological presentation, including a number of variants (Sesterhenn and Davis, 2004). They are subdivided into pure and mixed types. Based on this system, the following GCTs are distinguished: seminoma (i.e. classic and spermatocytic), teratoma, embryonal carcinoma, yolk sac tumor, and choriocarcinoma. Although this classification is correct based on pure morphological grounds, it underestimates the existence of a pathogenetic relationship(s) between some of these tumor types and an absence between others. Recognition of the pathobiological classification system (as will be discussed here) sheds new light on the supposed complexity of human GCTs and allows a more straightforward understanding of the experimental results found, thereby allowing a better interpretation in the pathobiological context. Distinction between these three entities is relevant from a clinical point of view as well.

The classification system we proposed is based on the interpretation of multidisciplinary findings, showing that in fact within the human testis,

three entities of GCTs exist (Oosterhuis and Looijenga, 2005; Table 1). These include the teratomas and yolk sac tumors of neonates and infants (referred to as type I GCTs), the seminomas and nonseminomatous GCTs of adolescents and young adults (referred to as type II GCTs), and the spermatocytic seminomas (referred to as type III GCTs). In the following paragraphs, these three entities of GCTs will be discussed in more detail, with special focus on the cell of origin, markers for early diagnosis, and genomic anomalies.

Normal and Abnormal Development in Human GCTs

Human GCTs mimic normal development to a certain extent. This is nicely illustrated at different levels, for example by the embryoid bodies found in type II nonseminomas that are highly similar to an early human embryo (Sesterhenn and Davis, 2004; see also below). The gene expression profile of these tumors is also highly similar to the counterparts of the different histologies found during normal development (Skotheim *et al.*, 2002; Sperger *et al.*, 2003). This observation has clinical implications, as shown by the value of the clinically informative serum markers AFP and hCG for the presence of yolk sac tumor and choriocarcinoma, respectively (IGC-CCG, 1997). In addition, the pattern of genomic imprinting (see below) and X inactivation is according to the expectations based on knowledge derived from investigations of normal development (Looijenga *et al.*, 1997; Looijenga *et al.*, 1998). In fact, these similarities between normal development and the tumors limit the value of the information derived from the tumors in the context of understanding the pathobiological steps, especially if the data are not compared to proper control(s). On the other hand, knowledge about this specific phenomenon of these tumors allows identification of novel (diagnostic) markers (see below), like OCT3/4 and the methylation status of the XIST gene (Kawakami *et al.*, 2004; Looijenga *et al.*, 2003b).

Besides the mentioned similarities, differences are also identified between normal development and GCTs. These include the delayed maturation of the cell of origin of type II GCTs, as well as the presence of genomic anomalies. Morphologically, CIS/ITGCNU cells mimic a primordial germ cell/gonocyte (see below). The genomic changes — e.g. amplifications, deletions, translocations, and mutations — are informative from a diagnostic point of view, and to identify the relevant gene(s) involved in the

pathogenesis of the cancer; they are also of importance for the development of relevant *in vivo* and/or *in vitro* models. However, it remains to be determined whether the changes reported are related to the early developmental stages of the cancer or are part of progression, like gain of 12p in type II GCTs (see below).

Genomic Imprinting and Cell of Origin of Human GCTs

Genomic imprinting is defined as the functional difference between the haploid set of chromosomes, depending on their parental origin (Wilkins and Haig, 2003). This phenomenon is restricted to mammals. It has, from an evolutionary point of view, been related to competition between the sexes. Its existence has been nicely demonstrated by nuclear transfer experiments, generating zygotes made up of two (haploid) sets of paternally imprinted or maternally imprinted chromosomes (McGrath and Solter, 1983; Surani *et al.*, 1986). The first, known as androgenote, shows a relative overgrowth of extraembryonic tissues; while the other variant, known as gynogenote, is characterized by an overrepresentation of somatic tissues. These experimental situations are represented by the naturally occurring gestational hydatidiform moles (showing only paternal imprinting) and dermoid cysts of the ovary (showing maternal imprinting). In fact, these have been suggested by us as specific types of GCTs (Oosterhuis and Looijenga, 2005).

The parent-specific functional difference between the paternal and maternal sets of chromosomes is due to epigenetic modifications of a selected number of genes that are established during the passage of the genome through the germ line. Because of the fact that this is tightly regulated, starting with the erasement of the biparental pattern (as originally present in the zygote) and the subsequent reprogramming depending on the sex of the individual, it is informative to determine the maturation stage of the germ cell from which the GCT originates (Kerjean *et al.*, 2000; Szabo and Mann, 1995).

While type I teratomas and yolk sac tumors show a partially erased pattern of genomic imprinting (Schneider *et al.*, 2001b), a fully erased pattern has been found for type II seminomas and nonseminomas (van Gurp *et al.*, 1994). In contrast, type III spermatocytic seminomas show a partial paternal pattern of genomic imprinting (Sievers *et al.*, 2005). These findings are in line with the hypothesis that type I GCTs originate from an (partially erased)

embryonic germ cell, type II GCTs from a PGC/gonocyte, and type III GCTs from a germ cell that matured further along the male germ cell lineage.

Risk Factors for Human GCTs

So far, no established risk factors have been identified for type I and III GCTs. In contrast, multiple risk factors are reported for type II GCTs, including cryptorchidism, familial predisposition, a previous GCT, internal hernia, and birth weight (Akre *et al.*, 1996). In addition, specific variants of a disturbed sexual differentiation are known as a risk factor. All these observations support the model that the initiating event in the pathogenesis of these tumors occurs during intrauterine development. This results in a partial/complete block of the maturation of a primordial germ cell/gonocyte to a spermatogonium. Niels Skakkebaek (2004) introduced the term testicular dysgenesis syndrome (TDS) to describe this phenomenon. It refers to the observations found in the general population of a reduced sperm quality, immaturity of testis, and an increased risk for type II GCTs. This has been related to the presence of compounds with an estrogen-like effect, although this has also been questioned (Hsieh *et al.*, 2002).

The fact that a reduced/blocked maturation of embryonic germ cells is found in all (clinical) situations known for an increased risk for this type of cancer limits the application of the currently identified diagnostic markers for CIS/ITGCNU and gonadoblastoma (GB), the precursor of dysgenetic gonads (see below). This is because all are found to be positive in embryonic germ cells, as well as in germ cells at older age that are characterized by a delayed/blocked maturation (De Meyts *et al.*, 1996; Honecker *et al.*, 2004; Rajpert-De Meyts *et al.*, 2003a; Stoop *et al.*, 2005). In other words, the markers available do not distinguish malignant from nonmalignant, but rather maturation-delayed, germ cells. The identification of such a marker would be highly beneficial in the diagnosis of the precursor of type II GCTs in young individuals, especially those with supposed germ cell maturation delay.

Because of clarity reasons, we prefer to distinguish the various groups of disturbed sexual development into those showing hypervirilization, under(hypo)virilization, and gonadal dysgenesis. Only patients with undervirilization and specific forms of gonadal dysgenesis are at risk to develop type II GCTs (Cools *et al.*, 2005). Patients with undervirilization always

have a Y chromosome in their karyotype. Interestingly, the risk for development of type II GCTs in the heterogeneous group of gonadal dysgenesis (as will be discussed elsewhere) is also associated with the presence of (part of) the Y chromosome. This is not the sex-determining region (including the *SRY* gene), but rather the pericentromeric region — known as the gonadoblastoma on the Y chromosome (GBY) — for which various genes might be of interest, including *TSPY* (see below).

Genomic Anomalies and Candidate Genes

Type I GCTs

So far, no recurrent genomic anomaly has been identified in type I teratomas (Mostert *et al.*, 2000; Veltman *et al.*, 2003). In contrast, recurrent imbalances have been found in type I yolk sac tumors. These include loss of 1p, 4, and 6q; and gain of 1q and 20q (Schneider *et al.*, 2001a; Veltman *et al.*, 2005). The array-based comparative genomic hybridization (CGH) approach revealed the common regions of overlap, allowing a more straightforward identification of the genes of interest. Although no candidate genes have been identified, identification of the genomic changes has been proven to be of value. This is demonstrated by the observation that we recently identified a pure yolk sac tumor in a postpubertal patient. Chromosomal analysis showed that this tumor contained type I GCT-specific genomic imbalances, and not those of type II GCTs (see below). Indeed, careful clinical file analysis demonstrated that this patient had a type I sacral teratoma at young age, making it a recurrent type I yolk sac tumor (Veltman *et al.*, 2005). A second case similar to this, diagnosed in an ovary of a female of 40 years, will be published elsewhere. It will be of interest to investigate whether the *Dnd* gene, as found to be responsible for the development of testicular teratomas of the mouse, might be involved in type I GCTs of neonates and infants (see below).

Type II GCTs

One of the striking observations in type II GCTs is their consistent aneuploidy, being hypertriploid for the seminomatous tumors and hypotriploid for the nonseminomatous elements (Oosterhuis *et al.*, 1989; van Echten-Arends *et al.*, 1995). This characteristic pattern was recently supported in

both primary tumors and derived cell lines, using high-throughput genomic approaches like array CGH and SNP (single nucleotide polymorphism) analyses (Bignell *et al.*, 2006; McIntyre *et al.*, 2004; Summersgill *et al.*, 2001b). The aneuploidy has been suggested to be due to the net loss of chromosomes during progression of the polyploid precursor cell (i.e. CIS/ITGCNU to nonseminoma), possibly via a stage of seminoma. The only possible exception might be the type II GCTs originating from dysgenetic gonads that were found to be near (diploid) (Bussey *et al.*, 1999). The reason(s) for aneuploidy of these tumors is unknown, but it might be due to an enhanced survival of cells that have undergone polyploidization to overcome stress, as reported in yeast and flowering plants (Comai *et al.*, 2000; Galitski *et al.*, 1999). We are currently investigating the possible candidate gene(s) involved in this process.

The recurrent genomic imbalances found in the invasive GCTs might be informative to identify the relevant gene(s). Various approaches have been undertaken in this context, including different candidate gene analyses as well as more general screens. One of the most interesting candidates so far is c-KIT (Rajpert-De Meyts and Skakkebaek, 1994; Strohmeyer *et al.*, 1995). It has been found to be mutated in a number of type II tumors, leading to a constitutively activated receptor (Kemmer *et al.*, 2004; Pauls *et al.*, 2004; Rapley *et al.*, 2004; Sakuma *et al.*, 2003). Interestingly, this has been associated with the development of bilateral disease (Looijenga *et al.*, 2003a; Tate *et al.*, 2005). Specific amplification of the wild-type c-KIT has been found in a selected number of seminomas, associated with overexpression (McIntyre *et al.*, 2005). Another interesting candidate is PTEN (Di Vizio *et al.*, 2005).

One of the most consistent genomic changes in invasive GCTs is the consistent gain of the short arm of chromosome 12, mostly as i(12p) (for review see Looijenga *et al.*, 2003c). It is generally accepted that gain of 12p is not the initiating event in the genesis of this type of cancer. This is demonstrated by the finding that aneuploidy precedes i(12p) formation (Geurts van Kessel *et al.*, 1989), in line with the absence of additional 12p copies in CIS/ITGCNU (Rosenberg *et al.*, 2000; Summersgill *et al.*, 2001a), although some debate on the actual timing of gain of 12p still exists (Almstrup *et al.*, 2005; Ottesen *et al.*, 2004). While the actual gene or genes involved are unknown, it is of interest that human embryonic stem (ES) cells

also developed additional copies of 12p during extensive *in vitro* growth (Cowan *et al.*, 2004; Draper *et al.*, 2003). An interesting model is that gain of 12p results in upregulation of genes, allowing cells to survive outside their natural microenvironment. This might be due to suppression of apoptosis. Indeed, we demonstrated an association between copy numbers of a restricted region of 12p and the level of apoptosis in these tumors (Roelofs *et al.*, 2000; Zafarana *et al.*, 2002). Although a number of candidates have been suggested, including BCAT1, it is expected that a combined investigation of both DNA copy numbers and expression analysis will eventually identify the relevant gene(s) (McIntyre *et al.*, 2004; Rodriguez *et al.*, 2003; Zafarana *et al.*, 2003).

Other recurrent changes are gain of chromosomes 7, 8, 22, and X; and loss of 4, 5, 11, 13, 18, and Y. The minimal overlapping regions have been identified in some cases, although no genes have been proven to be involved. Limited numbers of mutations of either tumor suppressor genes or proto-oncogenes have been identified in type II GCTs; these will not be discussed here. However, a recent mutational screen of the whole set of 512 protein kinases in 10 seminomas and 10 nonseminomas demonstrated a very low level of mutations (Bignell *et al.*, 2006). Besides the presence of c-KIT mutations, one STK10 mutation was found in a single tumor. This indicates that type II GCTs are not prone to mutations in these types of genes, in contrast to, for example, lung cancer and some breast cancers (Davies *et al.*, 2005; Stephens *et al.*, 2004). The mechanistic basis of the consistent aneuploidy and low tendency for mutations must be elucidated, and might be related to specific characteristics of a (embryonic) germ cell.

Type III GCTs

The spermatocytic seminomas, the GCTs of the elderly, have not been investigated in large series, mainly due to their low incidence in the general population (about 0.12 per 100 000 males). No correlation between the development of this type of GCT and reduced fertility has been reported. The limited studies on the genomic constitution are overall consistent in their findings, showing that the tumor cells may be diploid, tetraploid, or hypertetraploid (Looijenga *et al.*, 1994). This has been suggested as related to their capacity to at least partially undergo meiosis. Karyotyping and comparative genomic

hybridization data were in accordance with this ploidy heterogeneity, and revealed gain of chromosome 9 as the only consistent imbalance (Rosenberg *et al.*, 1998; Verdorfer *et al.*, 2004). Most cases contained predominantly numerical, and hardly structural, changes. One study suggested the presence of haploid cells, confirming their capability to undergo meiotic division. No mutations have been reported in these tumors so far. Various markers have been indicated to distinguish (classic) seminoma from spermatocytic seminoma, including c-KIT, PLAP, P53, CHK2, MAGE4A, p19INK4d, SSX2-3, XPA, and SCP1 (Rajpert-De Meyts *et al.*, 2003b; Stoop *et al.*, 2001). These observations support the knowledge that the spermatocytic seminomas originate from a germ cell at a later stage of maturation of germ cell development.

The bilateral occurrence of these type III GCTs still remains unexplained (Chung *et al.*, 2004; Cummings *et al.*, 1994; Eble, 1994). This observation, with the benign behavior of these tumors, suggests that the first hit in the pathogenesis of spermatocytic seminomas occurs during migration of the embryonic germ cells from the yolk sac to the genital ridge. In spite of this change, the cells are able to mature further, at least to the spermatogonium/spermatocyte stage. The finding of intratubular spermatocytic seminoma as the precursor of these tumors indicates that the cell of origin is indeed positioned at the luminal site of the tight junctions existing between the Sertoli cells. We recently demonstrated, using a multidisciplinary approach, that the germ cell stage representative for spermatocytic seminoma is a primary spermatocyte (Looijenga *et al.*, 2006). This study also indicated that the *DMRT1* gene, mapped to the short arm of chromosome 9, is a likely gene involved in the pathogenesis of this type of tumor.

Omnipotency of Type II GCTs and OCT3/4-POU5F1 as a Diagnostic Marker

Type II GCTs are known for their pluripotency. This is demonstrated by the possible presence of embryoid bodies in some nonseminomas, and the presence of both somatic tissue (teratoma, including endodermal, mesodermal, and ectodermal lineages) and extraembryonic tissue (yolk sac tumor and choriocarcinoma) (Sesterhenn and Davis, 2004; Fig. 1A). Moreover, we recently showed that these tumors are in fact omnipotent, because they are also capable of generating the germ cell lineage (Honecker *et al.*, 2005).

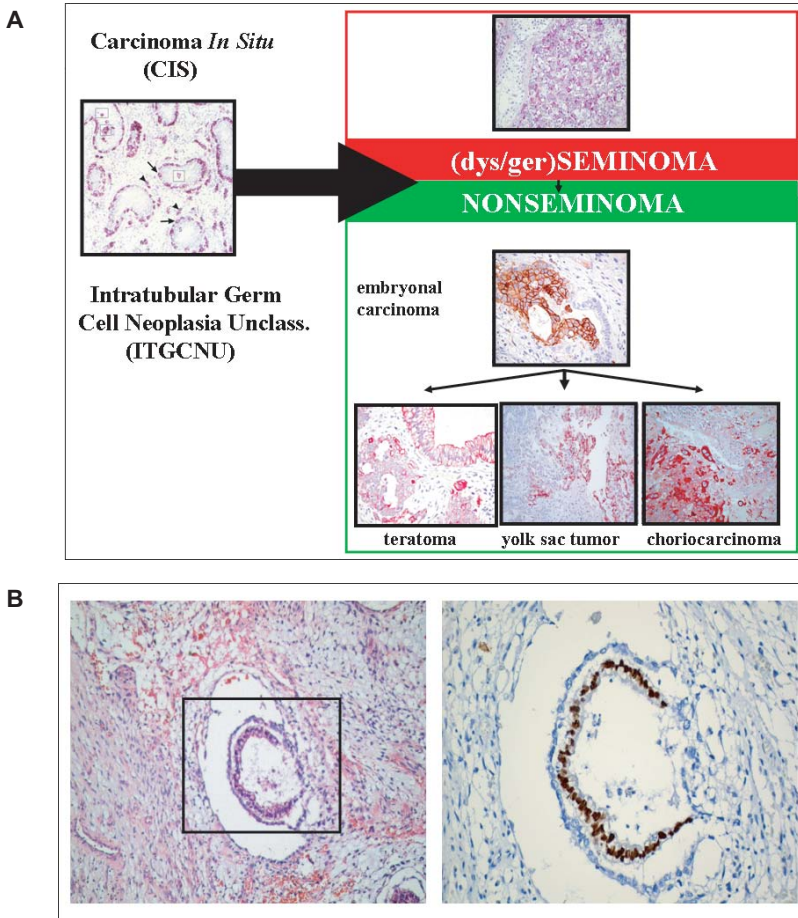

Fig. 1. A. Histological diversity of type II GCTs. The invasive tumors can be subdivided into seminomatous tumors (seminoma of the testis and mediastinum, dysgerminoma of the ovary, and germinoma of the brain; stained for alkaline phosphatase) and the different variants of nonseminoma: the undifferentiated component (embryonal carcinoma, stained for CD30), the somatic lineage of differentiation (teratoma, stained for cytokeratin), and the extraembryonic lineages (yolk sac tumor, stained for AFP; and choriocarcinoma, stained for hCG). **B. Immunohistochemistry for OCT3/4-POU5F1 on a nonseminoma containing an embryoid body, representing early intrauterine human development.** Note that the undifferentiated cells are stained positive.

Interestingly, this is in line with recent reports of the generation of the germ cell lineage from ES cells, both mouse and human (Hubner *et al.*, 2003; Toyooka *et al.*, 2003). This observation in type II GCTs, predominantly yolk sac tumors, has been made possible due to the availability of a number of

new markers for germ cells, including VASA, TSPY, and OCT3/4-POU5F1. The last one, OCT3/4-POU5F1, deserves special attention.

OCT3/4-POU5F1 was cloned from the mouse and human genomes, and was found to be the regulator of pluripotency (Nichols *et al.*, 1998; Niwa *et al.*, 2000; Rosner *et al.*, 1990; Scholer *et al.*, 1990). The gene is expressed in primordial germ cells and ES cells. This initiated our study to investigate the presence of mRNA of this gene in the various types of GCTs (Palumbo *et al.*, 2002). The presence of various pseudogenes complicated the interpretation of the data, which required specific analysis of the various types using restriction site investigation. In spite of this limitation, CIS/ITGCNU, seminoma, and embryonal carcinoma were positive; while the other variants were consistently negative. Subsequently, we tested both a polyclonal and a monoclonal antibody on a large series of tumors represented in tissue microarrays (TMA), including more than 4000 tumors of at least 100 different types, and the antibodies recognized the 3A variant (Looijenga *et al.*, 2003b).

The forementioned pattern of expression at the level of mRNA was confirmed at the protein level, supported by multiple independent studies (for review see de Jong *et al.*, 2005). In fact, OCT3/4-POU5F1 is now considered one of the most informative markers for the identification of CIS/ITGCNU, GB, seminomatous-type tumors, and embryonal carcinoma. This is irrespective of anatomical localization and clinical behavior (primary or metastasis, treatment-sensitive or treatment-resistant). The undifferentiated cells present in embryoid bodies are indeed nicely positive for this marker (see Fig. 1B). That OCT3/4-POU5F1 is involved in the regulation of differentiation in type II GCTs has been proven by *in vitro* experiments, in which the level of expression of the gene determined whether embryonal carcinoma cells remained undifferentiated or differentiated (Matin *et al.*, 2004).

The diagnostic value of OCT3/4-POU5F1 has been proven in multiple cases. These include two independent patients as having a type II GCT, one with a seminomatous tumor in the brain (known as germinoma) and one with a highly necrotic seminoma in the retroperitoneal cavity. This diagnosis could not have been made using the other markers available. The patients were thus treated for this highly sensitive tumor with either irradiation or cisplatin-based chemotherapy, and they responded as expected. It

is expected that other markers showing a similar pattern of expression, like NANOG (Cavaleri and Scholer, 2003; Chambers *et al.*, 2003; Mitsui *et al.*, 2003), will show the same level of informativity from a diagnostic point of view (Hart *et al.*, 2005; Hoei-Hansen *et al.*, 2005).

Various studies have suggested that OCT3/4-POU5F1 might act as a (proto-)oncogene. They observed that mouse ES cells dependent on the level of oct3/4 expression will generate more or less aggressive tumors upon transplantation (Gidekel *et al.*, 2003). This must be interpreted with caution because, by definition, ES cells with a lower oct3/4 expression will show a less malignant behavior, given that they are more differentiated (see above). That oct3/4 determines the fate of stem cells is nicely demonstrated by the formation of dysplasia upon induced expression in the skin and in the gastrointestinal tract (Hochedlinger *et al.*, 2005). The recently identified translocation involving this gene in a solid cancer might be due to the existing nuclear localization of the fused gene product, possibly established by the OCT3/4-POU5F1 sequence (Yamaguchi *et al.*, 2005).

The observation that mouse PGCs without oct3/4 do not differentiate, as would be expected based on the observations made in ES cells (see above), but rather die apoptotically is highly interesting (Kehler *et al.*, 2004). This demonstrates that the physiological role of oct3/4 depends on the cell type, which might involve regulation of differentiation or apoptosis. In type II GCTs, the role of OCT3/4-POU5F1 is still unclear, although we favor the model that its presence is predominantly the result of the intrinsic characteristic of the cell of origin of these tumors, being consistently positive for this protein. However, it is conceivable that in the CIS/ITGCNU and seminoma, as well as in some germ cells within GB, OCT3/4-POU5F1 supports the survival of the germ cells by suppression of apoptosis; while in the embryonal carcinoma cells, its function is regulation of pluripotency. In spite of this unclearness about the actual role of this protein, its diagnostic value is proven.

The Y Chromosome and Human GCTs

There is not a clear link between the Y chromosome and type I GCTs. In fact, this type of cancer is predominantly found in the sacral region of normal females at young age (Schneider *et al.*, 2004). This is in contrast to type II

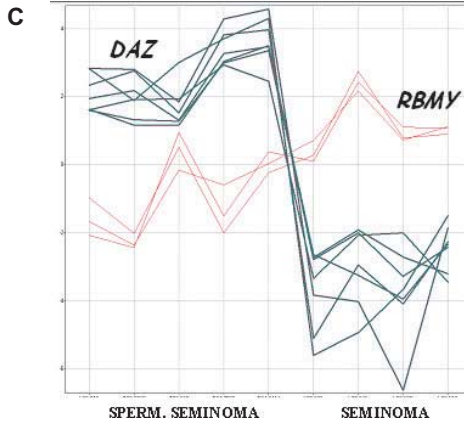
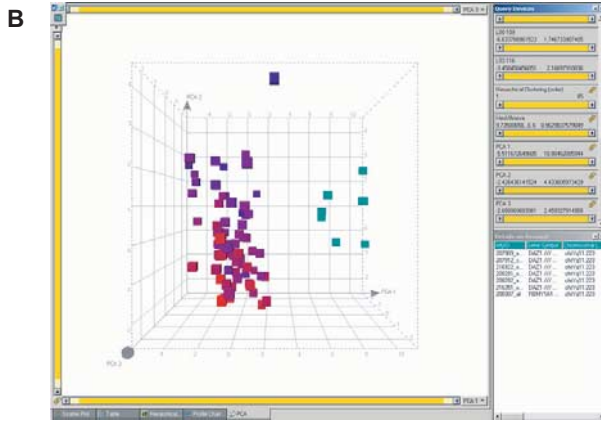
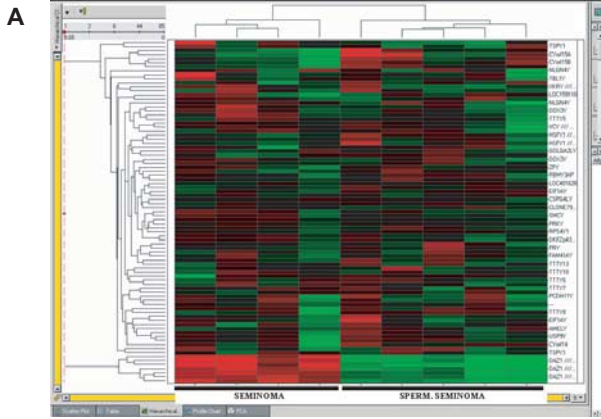

and III GCTs. The latter are only found in the postpubertal testis, and are therefore by definition related to the functional activity of the Y chromosome (see also below). Type II GCTs are mainly diagnosed in the adult testis, also after puberty. In addition, gonadal dysgenesis, particularly related to the presence of the GBY region, is a risk factor for the development of type II GCTs (Page, 1987). In some of these cases, the tumors are diagnosed before puberty; this indicates that, in these situations, induction of spermatogenesis is not required. As mentioned above, type II GCTs in the dysgenetic gonads are also different in their chromosomal constitution, although the gain of 12p is consistent.

The fact that the Y chromosome can be lost from the genome during tumor progression, as is also observed in representative cell lines, does not mean that the Y chromosome is not important in the (initial) development of this tumor. To investigate the possible role of the Y chromosome in more detail, we undertook various approaches. One included an analysis of the expression profile of all Y-mapped genes in a series of four seminomas and five spermatocytic seminomas. To this end, we performed expression profiling (Affymetrix A133 plus 2.0), of which the total data set is published elsewhere (Looijenga *et al.*, 2006). Unsupervised clustering and principle component analysis (PCA) demonstrated that, based on this selected number of genes, the seminomas and spermatocytic seminomas could be nicely separated from each other, with DAZ1–4 and RBMY as the most informative genes (see Fig. 2). Several copies of DAZ (deleted in azoospermia) are known (Reijo *et al.*, 2000; Skaletsky *et al.*, 2003; Yen, 2004). Interestingly, we also showed that the related gene DAZL (mapped to chromosome 3) is also informative to distinguish spermatocytic seminomas from seminomas (Looijenga *et al.*, 2006).

Previous studies demonstrated that TSPY (testis-specific protein of the Y chromosome) might be an interesting candidate for the GBY region,

←
Fig. 2. A. Results of unsupervised clustering based on the expression of all Y chromosome genes, as represented by the Affymetrix A133 plus 2.0 array. Note that the seminomas are nicely separated from the spermatocytic seminomas. **B. Principle component analysis of the expression data as described above.** Note that the DAZ and RBMY genes distinguish the seminomas from the spermatocytic seminomas. **C. Expression pattern of DAZ and RBMY in the different germ cell tumors.** Note that these genes are highly expressed in the spermatocytic seminomas and seminomas, respectively.

related to the development of gonadoblastomas (Delbridge *et al.*, 2004; Hildenbrand *et al.*, 1999; Lau *et al.*, 2000; Lau *et al.*, 2003; Schnieders *et al.*, 1996). It has also been found to be present in some prostate and hepatocellular cancers (Lau *et al.*, 2003; Yin *et al.*, 2005). TSPY is a highly repetitive gene and its function has been related to regulation of the cell cycle, in particular of meiosis. However, this gene does not distinguish seminomas from spermatocytic seminomas, based on the expression profiling investigations (see above). Indeed, immunohistochemical investigations showed that TSPY can be heterogeneously present in both types of GCTs (see Fig. 3 for seminomas). Interestingly, it can be completely lost in the invasive tumor, in spite of the presence of the Y chromosome in the karyotype. In contrast, TSPY is consistently present in all CIS/ITGCNUs and GBs tested; and, interestingly, the protein level is increased compared to that of adjacent normal germ cells (Kersemaekers *et al.*, 2005). It is unknown so far whether this is related, for example, to the proliferative activity of the tumor cells, which is currently under investigation.

OCT3/4-POU5F1 and TSPY Double-Positive Cells at Risk for Malignant Transformation?

The consistent presence of OCT3/4-TSPY in CIS/ITGCNUs and GBs, and the required presence of the GBY region for the development of type II GCTs, made us study the colocalization of OCT3/4-POU5F1 and TSPY. Using immunohistochemistry, we found that all preinvasive malignant germ cells were positive for both OCT3/4-POU5F1 and TSPY (Cools *et al.*, 2005; Kersemaekers *et al.*, 2005). In contrast, this specific costaining was rarely found during normal development. The mechanistic base for this phenomenon is so far unknown. We are currently testing the hypothesis that these double-positive cells are indeed the cells at risk to progress into invasive type II GCTs.

Animal Models for Human GCTs

In vivo and *in vitro* models have proven themselves regarding various aspects in the field of cancer research. These vary from the proof that a certain gene or pathway is involved in the pathogenesis to the testing of alternative treatment protocols. So far, the available animal models for human GCTs have been very limited. The mouse models, in particular the 129J mouse,

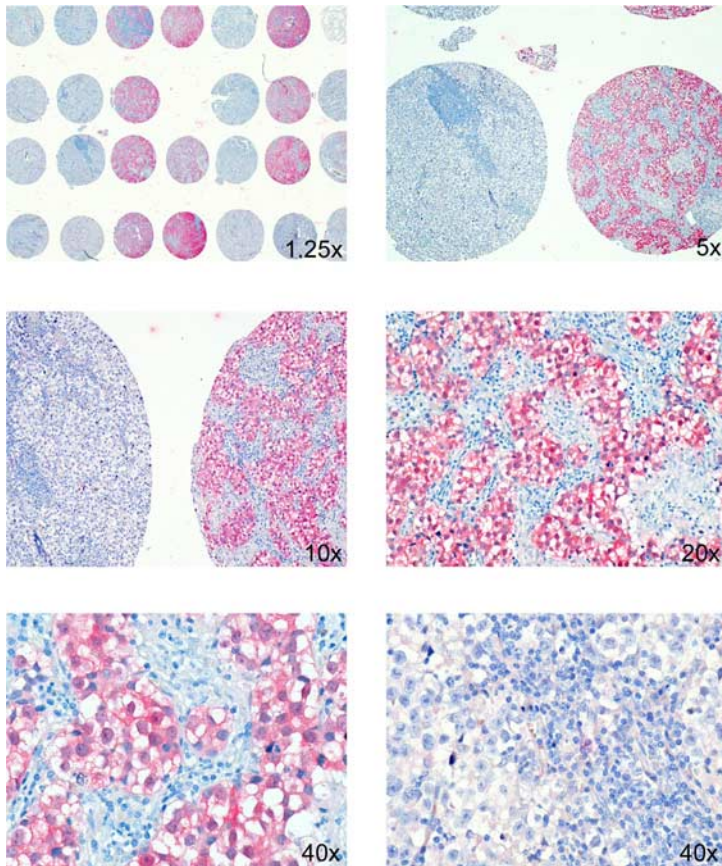

Fig. 3. Representative examples of immunohistochemistry for TSPY (antibody made available to us by Chris Lau) **on a tissue microarray containing various seminomas.** Note that some invasive tumors are strongly positive, while others are negative. These are diagnosed as seminomas based on morphology as well as on a positive staining for OCT3/4-POU5F1 (not shown).

have been found to be highly informative (Stevens, 1970; Stevens and Little, 1954). However, it must be kept in mind that these tumors represent type I GCTs, because they develop before puberty and because after extensive growth they can progress to yolk sac tumor (as reported for human tumors). In addition, no CIS/ITGCNU, GB, or seminoma components have been identified. In this context, the PTEN knockout animals must also be placed (Kimura *et al.*, 2003). The recently identified dead end mutation (*Ddn*), being the explanation of the Ter mutation, is relevant to be investigated in

this context (Youngren *et al.*, 2005). The Ter mutation results in the loss of germ cells and an increased risk for teratomas, independent of the genetic background. So far, it is unknown whether children with type I GCTs will suffer from reduced fertility in later life; this might be an interesting study to perform.

The canine seminomas of the testis most likely represent type III GCTs (Looijenga *et al.*, 1994) as well as the PUF-8 knockout-generated tumors in *C. elegans* (Subramaniam and Seydoux, 2003). The former develop mainly in older dogs, do not metastasize, and show a similar pattern of DNA content found in human type III GCTs. The tumors in *C. elegans* are characterized by the entrance of meiosis I and a subsequent reentry of the mitotic cycle, which is in line with recent expression data of spermatocytic seminomas (Looijenga *et al.*, 2006). Although various studies have suggested it, no informative model for type II GCTs has been identified yet. This significantly limits the study on this type of tumor.

Concluding Remarks

The combined investigation of the human GCTs — separated as types I, II, and III — together with their representative *in vivo* and/or *in vitro* model systems would increase the informativity of the different studies presented. This is relevant, for example, regarding type I GCTs (teratomas and yolk sac tumors) and murine teratomas, and type III GCTs (spermatocytic seminomas) and canine and *C. elegans* germ cell tumors. In addition, knowledge of the developmental potential of these tumors would allow a more powerful interpretation of the experimental data obtained that distinguishes the tumor-related characteristics from the intrinsic characteristics of the cell of origin and its derivatives. The development of a model system for type II GCTs would be highly informative to elucidate the relevance of suggested genes involved and the mechanism of the various risk factors, in particular those related to a maturation block of normal primordial germ cells/gonocytes.

Acknowledgments

The Dutch Cancer Society, the European Society for Pediatric Endocrinology (ESPE), and the Erasmus MC Revolving and Translational Research

grant are thanked for their financial support of the various studies discussed, as are the pathologists and urologists in and around Rotterdam for their continuous support and help in collecting the unique types of germ cell tumors. Last but not least, I would like to thank all the collaborators during the last few years in establishing this wealth of information on the pathobiology of germ cell tumors, especially my coworkers at the Laboratory for Experimental Patho-Oncology, Department of Pathology, Erasmus Medical Center. Remko Hersmus is especially thanked for his help in the analysis of the expression profiling of genes on the Y chromosome. Chris Lau (University of California, San Francisco, USA) is acknowledged for the TSPY antibody.

References

- Akre, O., Ekblom, A., Hsieh, C. C., Trichopoulos, D., and Adami, H. O. (1996). Testicular nonseminoma and seminoma in relation to perinatal characteristics. *J Natl Cancer Inst* **88**, 883–889.
- Almstrup, K., Hoei-Hansen, C. E., Nielsen, J. E., Wirkner, U., Ansgore, W., Skakkebaek, N. E., Rajpert-De Meyts, E., and Leffers, H. (2005). Genome-wide gene expression profiling of testicular carcinoma in situ progression into overt tumours. *Br J Cancer* **92**, 1934–1941.
- Bignell, G., Hunter, C., *et al.* (2006). Sequence analysis of the protein kinase gene family in human testicular germ-cell tumours of adolescents and adults. *Genes Chromosomes Cancer* **45**, 42–46.
- Bussey, K. J., Lawce, H. J., Olson, S. B., Arthur, D. C., Kalousek, D. K., Krailo, M., Giller, R., Heifetz, S., Womer, R., and Magenis, R. E. (1999). Chromosome abnormalities of eighty-one pediatric germ cell tumors: sex-, age-, site-, and histopathology-related differences — a Children's Cancer Group study. *Genes Chromosomes Cancer* **25**, 134–146.
- Cavaleri, F., and Scholer, H. R. (2003). Nanog: a new recruit to the embryonic stem cell orchestra. *Cell* **113**, 551–552.
- Chambers, I., Colby, D., Robertson, M., Nichols, J., Lee, S., Tweedie, S., and Smith, A. (2003). Functional expression cloning of Nanog, a pluripotency sustaining factor in embryonic stem cells. *Cell* **113**, 643–655.
- Chung, P. W., Bayley, A. J., Sweet, J., Jewett, M. A., Tew-George, B., Gospodarowicz, M. K., and Warde, P. R. (2004). Spermatocytic seminoma: a review. *Eur Urol* **45**, 495–498.
- Comai, L., Tyagi, A. P., Winter, K., Holmes-Davis, R., Reynolds, S. H., Stevens, Y., and Byers, B. (2000). Phenotypic instability and rapid gene silencing in newly formed arabidopsis allotetraploids. *Plant Cell* **12**, 1551–1568.
- Cools, M., van Aerde, K., Kersemaekers, A. M., Boter, M., Drop, S. L. S., Wolffenbuttel, K. P., Oosterhuis, J. W., and Looijenga, L. H. J. (2005). From gonadal maturation delay towards carcinoma in situ of the testes in patients with undervirilization syndromes. *J Clin Endocrinol Metab* **90**, 5295–5303.

- Cowan, C. A., Klimanskaya, I., McMahon, J., Atienza, J., Witmyer, J., Zucker, J. P., Wang, S., Morton, C. C., McMahon, A. P., Powers, D., and Melton, D. A. (2004). Derivation of embryonic stem-cell lines from human blastocysts. *N Engl J Med* **350**, 1353–1356.
- Cummings, O. W., Ulbright, T. M., Eble, J. N., and Roth, L. M. (1994). Spermatocytic seminoma: an immunohistochemical study. *Hum Pathol* **25**, 54–59.
- Davies, H., Hunter, C., Smith, R., Stephens, P., Greenman, C., Bignell, G., Teague, J., Butler, A., Edkins, S., Stevens, C., *et al.* (2005). Somatic mutations of the protein kinase gene family in human lung cancer. *Cancer Res* **65**, 7591–7595.
- de Jong, J., Stoop, J., Dohle, G. R., Bangma, C. H., Kliffen, M., van Esser, J. W. J., van den Bent, M., Kros, J. M., Oosterhuis, J. W., and Looijenga, L. H. J. (2005). Diagnostic value of OCT3/4 for pre-invasive and invasive testicular germ cell tumors. *J Pathol* **206**, 242–249.
- De Meyts, E. R., Jorgensen, N., Mueller, J., and Skakkebaek, N. E. (1996). Prolonged expression of the c-kit receptor in germ cells of intersex fetal testes. *J Pathol* **178**, 166–169.
- Delbridge, M. L., Longepied, G., Depetris, D., Mattei, M. G., Disteche, C. M., Marshall Graves, J. A., and Mitchell, M. J. (2004). TSPY, the candidate gonadoblastoma gene on the human Y chromosome, has a widely expressed homologue on the X — implications for Y chromosome evolution. *Chromosome Res* **12**, 345–356.
- Di Vizio, D., Cito, L., Boccia, A., Chieffi, P., Insabato, L., Pettinato, G., Motti, M. L., Schepis, F., D'Amico, W., Fabiani, F., *et al.* (2005). Loss of the tumor suppressor gene PTEN marks the transition from intratubular germ cell neoplasias (ITGCN) to invasive germ cell tumors. *Oncogene* **10**, 1882–1894.
- Donovan, P. J., and de Miguel, M. P. (2003). Turning germ cells into stem cells. *Curr Opin Genet Dev* **13**, 463–471.
- Draper, J. S., Smith, K., Gokhale, P., Moore, H. D., Maltby, E., Johnson, J., Meisner, L., Zwaka, T. P., Thomson, J. A., and Andrews, P. W. (2003). Recurrent gain of chromosomes 17q and 12 in cultured human embryonic stem cells. *Nat Biotechnol* **22**, 53–54.
- Eble, J. N. (1994). Spermatocytic seminoma. *Hum Pathol* **25**, 1035–1042.
- Galitski, T., Saldanha, A. J., Styles, C. A., Lander, E. S., and Fink, G. R. (1999). Ploidy regulation of gene expression. *Science* **285**, 251–254.
- Geurts van Kessel, A., van Drunen, E., de Jong, B., Oosterhuis, J. W., Langeveld, A., and Mulder, M. P. (1989). Chromosome 12q heterozygosity is retained in i(12p)-positive testicular germ cell tumor cells. *Cancer Genet Cytogenet* **40**, 129–134.
- Gidekel, S., Pizov, G., Bergman, Y., and Pikarsky, E. (2003). Oct-3/4 is a dose-dependent oncogenic fate determinant. *Cancer Cell* **4**, 361–370.
- Hart, A. H., Hartley, L., Parker, K., Ibrahim, M., Looijenga, L. H. J., Pauchnick, M. C. W. C., and Robb, L. (2005). The pluripotency homeobox gene NANOG is expressed in human germ cell tumors. *Cancer* **14**, 2092–2098.
- Hildenbrand, R., Schroder, W., Brude, E., Schepler, A., Konig, R., Stutte, H. J., and Arnemann, J. (1999). Detection of TSPY protein in a unilateral microscopic gonadoblastoma of a Turner mosaic patient with a Y-derived marker chromosome. *J Pathol* **189**, 623–626.
- Hochedlinger, K., Yamada, Y., Beard, C., and Jaenisch, R. (2005). Ectopic expression of Oct-4 blocks progenitor-cell differentiation and causes dysplasia in epithelial tissues. *Cell* **121**, 465–477.

- Hoei-Hansen, C. E., Almstrup, K., Nielsen, J. E., Brask Sonne, S., Graem, N., Skakkebaek, N. E., Leffers, H., and Rajpert-De Meyts, E. (2005). Stem cell pluripotency factor NANOG is expressed in human fetal gonocytes, testicular carcinoma in situ and germ cell tumours. *Histopathology* **47**, 48–56.
- Honecker, F., Stoop, H., de Krijger, R., Lau, Y.-F. C., Castrillon, D. H., Bokemeyer, C., and Looijenga, L. H. J. (2004). Pathobiological implications of the expression of markers of testicular carcinoma in situ by fetal germ cells. *J Pathol* **203**, 849–857.
- Honecker, F., Stoop, H., Mayer, F., Bokemeyer, C., Castrillon, D. H., Lau, Y.-F. C., Looijenga, L. H. J., and Oosterhuis, J. W. (2005). Germ cell lineage differentiation in nonseminomatous germ cell tumors. *J Pathol* **208**, 395–400.
- Hsieh, C. C., Lambe, M., Trichopoulos, D., Ekbom, A., Akre, O., and Adami, H. O. (2002). Early life exposure to oestrogen and testicular cancer risk: evidence against an aetiological hypothesis. *Br J Cancer* **86**, 1363–1364.
- Hubner, K., Fuhrmann, G., Christenson, L. K., Kehler, J., Reinbold, R., De La Fuente, R., Wood, J., Strauss, J. F., 3rd, Boiani, M., and Scholer, H. R. (2003). Derivation of oocytes from mouse embryonic stem cells. *Science* **300**, 1251–1256.
- International Germ Cell Cancer Collaborative Group (IGCCCG). (1997). International Germ Cell Consensus Classification: a prognostic factor-based staging system for metastatic germ cell cancers. *J Clin Oncol* **15**, 594–603.
- Johnson, J., Bagley, J., Skaznik-Wikiel, M., Lee, H. J., Adams, G. B., Niikura, Y., Tschudy, K. S., Tilly, J. C., Cortes, M. L., Forkert, R., *et al.* (2005). Oocyte generation in adult mammalian ovaries by putative germ cells in bone marrow and peripheral blood. *Cell* **122**, 303–315.
- Kawakami, T., Okamoto, K., Ogawa, O., and Okada, Y. (2004). XIST unmethylated DNA fragments in male-derived plasma as a tumour marker for testicular cancer. *Lancet* **363**, 40–42.
- Kehler, J., Tolkunova, E., Koschorz, B., Pesce, M., Gentile, L., Boiani, M., Lomeli, H., Nagy, A., McLaughlin, K. J., Scholer, H. R., and Tomilin, A. (2004). Oct4 is required for primordial germ cell survival. *EMBO Rep* **5**, 1078–1083.
- Kemmer, K., Corless, C. L., Fletcher, J. A., McGreevey, L., Haley, A., Griffith, D., Cummings, O. W., Wait, C., Town, A., and Heinrich, M. C. (2004). KIT mutations are common in testicular seminomas. *Am J Pathol* **164**, 305–313.
- Kerjean, A., Dupont, J. M., Vasseur, C., Le Tessier, D., Cuisset, L., Paldi, A., Jouannet, P., and Jeanpierre, M. (2000). Establishment of the paternal methylation imprint of the human H19 and MEST/PEG1 genes during spermatogenesis. *Hum Mol Genet* **9**, 2183–2187.
- Kersemaekers, A. M., Honecker, F., Cools, M., Stoop, H., Molier, M., Wolffenbuttel, K. P., Bokemeyer, C., Li, Y., Lau, Y.-F. C., Oosterhuis, J. W., and Looijenga, L. H. J. (2005). Identification of germ cells at risk for neoplastic transformation in gonadoblastomas: an immunohistochemical study for OCT3/4 and TSPY. *Hum Pathol* **36**, 512–521.
- Kimura, T., Suzuki, A., Fujita, Y., Yomogida, K., Lomeli, H., Asada, N., Ikeuchi, M., Nagy, A., Mak, T. W., and Nakano, T. (2003). Conditional loss of PTEN leads to testicular teratoma and enhances embryonic germ cell production. *Development* **130**, 1691–1700.
- Lau, Y., Chou, P., Iezzoni, J., Alonzo, J., and Komuves, L. (2000). Expression of a candidate gene for the gonadoblastoma locus in gonadoblastoma and testicular seminoma. *Cytogenet Cell Genet* **91**, 160–164.

- Lau, Y. F., Lau, H. W., and Komuves, L. G. (2003). Expression pattern of a gonadoblastoma candidate gene suggests a role of the Y chromosome in prostate cancer. *Cytogenet Genome Res* **101**, 250–260.
- Looijenga, L. H. J., de Leeuw, P. J. C., van Oorschot, M., van Gulp, R. J. H. L. M., Stoop, H., Gillis, A. J. M., de Gouveia Brazao, C. A., Weber, A., Kirkels, W. J., van Dijk, T., *et al.* (2003a). Stem cell factor receptor (c-KIT) codon 816 mutations predict development of bilateral testicular germ cell tumors. *Cancer Res* **63**, 7674–7678.
- Looijenga, L. H. J., Gillis, A. J. M., van Gulp, R. J. H. L. M., Verkerk, A. J. M. H., and Oosterhuis, J. W. (1997). X inactivation in human testicular tumors. XIST expression and androgen receptor methylation status. *Am J Pathol* **151**, 581–590.
- Looijenga, L. H. J., Hersmus, R., Gillis, A., Stoop, J., van Gulp, R. J. H. L. M., Veltman, J., Beverloo, B., van Drunen, E., Geurts van Kessel, A., Reijo Pera, R., Schneider, D. T., Summersgill, B., Shipley, J., McIntyre, A., van der Spek, P., Schoenmakers, E., and Oosterhuis, J. W. (2006). Genomic and expression profiling of human spermatocytic seminomas: primary spermatocyte as tumorigenic precursor and DMRT1 as candidate chromosome 9 gene. *Cancer Res* **66**, 290–302.
- Looijenga, L. H. J., Olie, R. A., van der Gaag, I., van Sluijs, F. J., Matoska, J., Ploem-Zaaijer, J., Knepfle, C., and Oosterhuis, J. W. (1994). Seminomas of the canine testis. Counterpart of spermatocytic seminoma of men? *Lab Invest* **71**, 490–496.
- Looijenga, L. H. J., Stoop, H., de Leeuw, P. J. C., de Gouveia Brazao, C. A., Gillis, A. J. M., van Roozendaal, K. E. P., van Zoelen, E. J. J., Weber, R. F. A., Wolffebuttel, K. P., van Dekken, H., *et al.* (2003b). POU5F1 (OCT3/4) identifies cells with pluripotent potential in human germ cell tumors. *Cancer Res* **63**, 2244–2250.
- Looijenga, L. H. J., Verkerk, A. J. M. H., Dekker, M. C., van Gulp, R. J. H. L. M., Gillis, A. J. M., and Oosterhuis, J. W. (1998). Genomic imprinting in testicular germ cell tumours. In: *Germ Cell Tumours IV*, I. Appleyard, ed., John Libbey & Company Ltd., London, pp. 41–50.
- Looijenga, L. H. J., Zafarana, G., Grygalewicz, B., Summersgill, B. M., Debiec-Rychter, M., Veltman, J., Schoenmakers, E. F., Rodriguez, S., Jafer, O., Clark, J., *et al.* (2003c). Role of gain of 12p in germ cell tumour development. *APMIS* **111**, 161–173.
- Matin, M. M., Walsh, J. R., Gokhale, P. J., Draper, J. S., Bahrami, A. R., Morton, I., Moore, H. D., and Andrews, P. W. (2004). Specific knockdown of Oct4 and beta2-microglobulin expression by RNA interference in human embryonic stem cells and embryonic carcinoma cells. *Stem Cells* **22**, 659–668.
- McGrath, J., and Solter, D. (1983). Nuclear transplantation in mouse embryos. *J Exp Zool* **228**, 355–362.
- McIntyre, A., Summersgill, B., Grygalewicz, B., Gillis, A. J., Stoop, H., van Gulp, R. J. H. L. M., Dennis, N., Fisher, C., Huddart, R., Cooper, C., *et al.* (2005). Amplification and overexpression of the KIT gene is associated with progression in the seminoma subtype of testicular germ cell tumors of adolescents and adults. *Cancer Res* **65**, 8085–8089.
- McIntyre, A., Summersgill, B., Jafer, O., Rodriguez, S., Zafarana, G., Oosterhuis, J. W., Gillis, A. J., Looijenga, L., Cooper, C., Huddart, R., *et al.* (2004). Defining minimum genomic regions of imbalance involved in testicular germ cell tumors of adolescents and adults through genome wide microarray analysis of cDNA clones. *Oncogene* **23**, 9142–9147.

- Mitsui, K., Tokuzawa, Y., Itoh, H., Segawa, K., Murakami, M., Takahashi, K., Maruyama, M., Maeda, M., and Yamanaka, S. (2003). The homeoprotein Nanog is required for maintenance of pluripotency in mouse epiblast and ES cells. *Cell* **113**, 631–642.
- Mostert, M. C., Rosenberg, C., Stoop, H., Schuyer, M., Timmer, A., Oosterhuis, J. W., and Looijenga, L. H. J. (2000). Comparative genomic and in situ hybridization of germ cell tumors of the infantile testis. *Lab Invest* **80**, 1055–1064.
- Nichols, J., Zevnik, B., Anastasiadis, K., Niwa, H., Klewe-Nebenius, D., Chambers, I., Scholer, H., and Smith, A. (1998). Formation of pluripotent stem cells in the mammalian embryo depends on the POU transcription factor Oct4. *Cell* **95**, 379–391.
- Niwa, H., Miyazaki, J., and Smith, A. G. (2000). Quantitative expression of Oct-3/4 defines differentiation, dedifferentiation or self-renewal of ES cells. *Nat Genet* **24**, 372–376.
- Oosterhuis, J. W., Castedo, S. M. M. J., de Jong, B., Cornelisse, C. J., Dam, A., Sleijfer, D. T., and Schraffordt Koops, H. (1989). Ploidy of primary germ cell tumors of the testis. Pathogenetic and clinical relevance. *Lab Invest* **60**, 14–20.
- Oosterhuis, J. W., and Looijenga, L. H. (2005). Testicular germ-cell tumours in a broader perspective. *Nat Rev Cancer* **5**, 210–222.
- Ottesen, A. M., Larsen, J., Gerdes, T., Larsen, J. K., Lundsteen, C., Skakkebaek, N. E., and Rajpert-De Meyts, E. (2004). Cytogenetic investigation of testicular carcinoma in situ and early seminoma by high-resolution comparative genomic hybridization analysis of subpopulations flow sorted according to DNA content. *Cancer Genet Cytogenet* **149**, 89–97.
- Page, D. C. (1987). Hypothesis: a Y-chromosomal gene causes gonadoblastoma in dysgenetic gonads. *Development* **101**(Suppl), 151–155.
- Palumbo, C., van Roozendaal, K., Gillis, A. J. M., van Gorp, R. J. H. L. M., de Munnik, H., Oosterhuis, J. W., van Zoelen, E. J. J., and Looijenga, L. H. J. (2002). Expression of the PDGF alpha-receptor 1.5 kb transcript, OCT-4 and c-KIT in human normal and malignant tissues. Implications for the early diagnosis of testicular germ cell tumors and for our understanding of regulatory mechanisms. *J Pathol* **196**, 467–477.
- Pauls, K., Wardelmann, E., Merkelbach-Bruse, S., Buttner, R., and Zhou, H. (2004). c-KIT codon 816 mutation in a recurrent and metastatic dysgerminoma of a 14-year-old girl: case study. *Virchows Arch* **445**, 651–654.
- Rajpert-De Meyts, E., Bartkova, J., Samson, M., Hoei-Hansen, C. E., Frydelund-Larsen, L., Bartek, J., and Skakkebaek, N. E. (2003a). The emerging phenotype of the testicular carcinoma in situ germ cell. *APMIS* **111**, 267–278, discussion 278–279.
- Rajpert-De Meyts, E., Jacobsen, G. K., Bartkova, J., Aubry, F., Samson, M., Bartek, J., and Skakkebaek, N. E. (2003b). The immunohistochemical expression pattern of Chk2, p53, p19INK4d, MAGE-A4 and other selected antigens provides new evidence for the premeiotic origin of spermatocytic seminoma. *Histopathology* **42**, 217–226.
- Rajpert-De Meyts, E., and Skakkebaek, N. E. (1994). Expression of the c-kit protein product in carcinoma-in-situ and invasive testicular germ cell tumours. *Int J Androl* **17**, 85–92.
- Rapley, E. A., Hockley, S., Warren, W., Johnson, L., Huddart, R., Crockford, G., Forman, D., Leahy, M. G., Oliver, D. T., Tucker, K., et al. (2004). Somatic mutations of KIT in familial testicular germ cell tumours. *Br J Cancer* **90**, 2397–2401.
- Reijo, R. A., Dorfman, D. M., Slee, R., Renshaw, A. A., Loughlin, K. R., Cooke, H., and Page, D. C. (2000). DAZ family proteins exist throughout male germ cell development

- and transit from nucleus to cytoplasm at meiosis in humans and mice. *Biol Reprod* **63**, 1490–1496.
- Rodriguez, S., Jafer, O., Goker, H., Summersgill, B. M., Zafarana, G., Gillis, A. J. M., van Gurp, R. J. H. L. M., Oosterhuis, J. W., Lu, Y.-J., Huddart, R., *et al.* (2003). Expression profile of genes from 12p in testicular germ cell tumors of adolescents and adults associated with i(12p) and amplification at 12p11.2-p12.1. *Oncogene* **22**, 1880–1891.
- Roelofs, H., Mostert, M. C., Pompe, K., Zafarana, G., van Oorschot, M., van Gurp, R. H. J. L. M., Gillis, A. J. M., Stoop, H., Beverloo, B., Oosterhuis, J. W., *et al.* (2000). Restricted 12p amplification and RAS mutation in human germ cell tumors of the adult testis. *Am J Pathol* **157**, 1155–1166.
- Rosenberg, C., Mostert, M. C., Bakker Schut, T., van de Pol, M., van Echten-Arends, J., de Jong, B., Raap, T., Tanke, H., Oosterhuis, J. W., and Looijenga, L. H. J. (1998). Chromosomal constitution of human spermatocytic seminomas: comparative genomic hybridization supported by conventional and interphase cytogenetics. *Genes Chromosomes Cancer* **23**, 286–291.
- Rosenberg, C., van Gurp, R. J. H. L. M., Geelen, E., Oosterhuis, J. W., and Looijenga, L. H. J. (2000). Overrepresentation of the short arm of chromosome 12 is related to invasive growth of human testicular seminomas and nonseminomas. *Oncogene* **19**, 5858–5862.
- Rosner, M. H., Vigano, M. A., Ozato, K., Timmons, P. M., Poirier, F., Rigby, P. W., and Staudt, L. M. (1990). A POU-domain transcription factor in early stem cells and germ cells of the mammalian embryo. *Nature* **345**, 686–692.
- Sakuma, Y., Sakurai, S., Oguni, S., Hironaka, M., and Saito, K. (2003). Alterations of the c-kit gene in testicular germ cell tumors. *Cancer Sci* **94**, 486–491.
- Schneider, D. T., Calaminus, G., Koch, S., Teske, C., Schmidt, P., Haas, R. J., Harms, D., and Gobel, U. (2004). Epidemiologic analysis of 1,442 children and adolescents registered in the German germ cell tumor protocols. *Pediatr Blood Cancer* **42**, 169–175.
- Schneider, D. T., Schuster, A. E., Fritsch, M. K., Calaminus, G., Harms, D., Gobel, U., and Perlman, E. J. (2001a). Genetic analysis of childhood germ cell tumors with comparative genomic hybridization. *Klin Padiatr* **213**, 204–211.
- Schneider, D. T., Schuster, A. E., Fritsch, M. K., Hu, J., Olson, T., Lauer, S., Gobel, U., and Perlman, E. J. (2001b). Multipoint imprinting analysis indicates a common precursor cell for gonadal and nongonadal pediatric germ cell tumors. *Cancer Res* **61**, 7268–7276.
- Schmieders, F., Dork, T., Arnemann, J., Vogel, T., Werner, M., and Schmidtke, J. (1996). Testis-specific protein, Y-encoded (TSPY) expression in testicular tissues. *Hum Mol Genet* **5**, 1801–1807.
- Scholer, H. R., Dressler, G. R., Balling, R., Rohdewohld, H., and Gruss, P. (1990). Oct-4: a germline-specific transcription factor mapping to the mouse t-complex. *EMBO J* **9**, 2185–2195.
- Sesterhenn, I. A., and Davis, C. J., Jr. (2004). Pathology of germ cell tumors of the testis. *Cancer Control* **11**, 374–387.
- Sievers, S., Alemzour, K., Zahn, S., Perlman, E. J., Gillis, A. J., Looijenga, L. H., Gobel, U., and Schneider, D. T. (2005). IGF2/H19 imprinting analysis of human germ cell tumors (GCTs) using the methylation-sensitive single-nucleotide primer extension method reflects the origin of GCTs in different stages of primordial germ cell development. *Genes Chromosomes Cancer* **44**, 256–264.

- Skakkebaek, N. E. (2004). Testicular dysgenesis syndrome: new epidemiological evidence. *Int J Androl* **27**, 189–191.
- Skaletsky, H., Kuroda-Kawaguchi, T., Minx, P. J., Cordum, H. S., Hillier, L., Brown, L. G., Repping, S., Pyntikova, T., Ali, J., Bieri, T., *et al.* (2003). The male-specific region of the human Y chromosome is a mosaic of discrete sequence classes. *Nature* **423**, 825–837.
- Skotheim, R. I., Monni, O., Mousses, S., Fossa, S. D., Kallioniemi, O. P., Lothe, R. A., and Kallioniemi, A. (2002). New insights into testicular germ cell tumorigenesis from gene expression profiling. *Cancer Res* **62**, 2359–2364.
- Sperger, J. M., Chen, X., Draper, J. S., Antosiewicz, J. E., Chon, C. H., Jones, S. B., Brooks, J. D., Andrews, P. W., Brown, P. O., and Thomson, J. A. (2003). Gene expression patterns in human embryonic stem cells and human pluripotent germ cell tumors. *Proc Natl Acad Sci U S A* **100**, 13350–13355.
- Stallock, J., Molyneaux, K., Schaible, K., Knudson, C. M., and Wylie, C. (2003). The pro-apoptotic gene Bax is required for the death of ectopic primordial germ cells during their migration in the mouse embryo. *Development* **130**, 6589–6597.
- Stephens, P., Hunter, C., Bignell, G., Edkins, S., Davies, H., Teague, J., Stevens, C., O'Meara, S., Smith, R., Parker, A., *et al.* (2004). Lung cancer: intragenic ERBB2 kinase mutations in tumours. *Nature* **431**, 525–526.
- Stevens, L. C. (1970). Experimental production of testicular teratomas in mice of strains 129, A/He, and their F1 hybrids. *J Natl Cancer Inst* **44**(4), 923–929.
- Stevens, L. C., and Little, C. C. (1954). Spontaneous testicular teratomas in an inbred strain of mice. *Proc Natl Acad Sci U S A* **40**, 1080–1087.
- Stoop, H., Honecker, F., de Krijger, R., Bokemeyer, C., and Looijenga, L. H. J. (2005). Differentiation and development of human female germ cells during prenatal gonadogenesis: an immunohistochemical study. *Hum Reprod* **20**, 1466–1476.
- Stoop, H., van Gorp, R. J. H. L. M., de Krijger, R., Geurts van Kessel, A., Koberle, B., Oosterhuis, J. W., and Looijenga, L. H. J. (2001). Reactivity of germ cell maturation stage-specific markers in spermatocytic seminoma: diagnostic and etiological implications. *Lab Invest* **81**, 919–928.
- Strohmeyer, T., Reese, D., Press, M., Ackermann, R., Hartmann, M., and Slamon, D. (1995). Expression of the c-kit proto-oncogene and its ligand stem cell factor (SCF) in normal and malignant human testicular tissue. *J Urol* **153**, 511–515.
- Subramaniam, K., and Seydoux, G. (2003). Dedifferentiation of primary spermatocytes into germ cell tumors in *C. elegans* lacking the Pumilio-like protein PUF-8. *Curr Biol* **13**, 134–139.
- Summersgill, B., Osin, P., Lu, Y. J., Huddart, R., and Shipley, J. (2001a). Chromosomal imbalances associated with carcinoma in situ and associated testicular germ cell tumours of adolescents and adults. *Br J Cancer* **85**, 213–220.
- Summersgill, B. M., Jafer, O., Wang, R., Goker, H., Niculescu-Duvaz, I., Huddart, R., and Shipley, J. (2001b). Definition of chromosome aberrations in testicular germ cell tumor cell lines by 24-color karyotyping and complementary molecular cytogenetic analyses. *Cancer Genet Cytogenet* **128**, 120–129.
- Surani, M. A., Barton, S. C., and Norris, M. L. (1986). Nuclear transplantation in the mouse: heritable differences between parental genomes after activation of the embryonic genome. *Cell* **45**, 127–136.

- Szabo, P. E., and Mann, J. R. (1995). Biallelic expression of imprinted genes in the mouse germ line: implications for erasure, establishment, and mechanisms of genomic imprinting. *Genes Dev* **9**, 1857–1868.
- Tate, G., Suzuki, T., Kishimoto, K., and Mitsuya, T. (2005). A c-KIT codon 816 mutation, D816H, in the testicular germ cell tumor: case report of a Japanese patient with bilateral testicular seminomas. *Acta Med Okayama* **59**, 33–36.
- Toyooka, Y., Tsunekawa, N., Akasu, R., and Noce, T. (2003). Embryonic stem cells can form germ cells in vitro. *Proc Natl Acad Sci U S A* **100**, 11457–11462.
- van Echten-Arends, J., Oosterhuis, J. W., Looijenga, L. H. J., Wiersema, J., te Meerman, G., Schraffordt Koops, H., Sleijfer, D. T., and de Jong, B. (1995). No recurrent structural abnormalities in germ cell tumors of the adult testis apart from i(12p). *Genes Chromosomes Cancer* **14**, 133–144.
- van Gurp, R. J. H. L. M., Oosterhuis, J. W., Kalscheuer, V., Mariman, E. C. M., and Looijenga, L. H. J. (1994). Human testicular germ cell tumors show biallelic expression of the H19 and IGF2 gene. *J Natl Cancer Inst* **86**, 1070–1075.
- Veltman, I., Schepens, M. T., Looijenga, L. H. J., Strong, L. C., and Geurts van Kessel, A. (2003). Germ cell tumours in neonates and infants: a distinct subgroup? *APMIS* **111**, 152–160.
- Veltman, I., Veltman, J., Jeanssen, I., Hulsbergen-van de Kaa, C. A., Zahn, S., Schneider, D., Looijenga, L. H. J., Gobell, U., and Geurts van Kessel, A. (2005). Identification of recurrent chromosomal aberrations in germ cell tumors of neonates and infants using genome-wide array-based comparative genomic hybridization. *Genes Chromosomes Cancer* **43**, 367–376.
- Verdorfer, I., Rogatsch, H., Tzankov, A., Steiner, H., and Mikuz, G. (2004). Molecular cytogenetic analysis of human spermatocytic seminomas. *J Pathol* **204**, 277–281.
- Wilkins, J. F., and Haig, D. (2003). What good is genomic imprinting: the function of parent-specific gene expression. *Nat Rev Genet* **4**, 359–368.
- Yamaguchi, S., Yamazaki, Y., Ishikawa, Y., Kawaguchi, N., Mukai, H., and Nakamura, T. (2005). EWSR1 is fused to PU5F1 in a bone tumor with translocation t(6;22)(p21;q12). *Genes Chromosomes Cancer* **43**, 217–222.
- Yen, P. H. (2004). Putative biological functions of the DAZ family. *Int J Androl* **27**, 125–129.
- Yin, Y. H., Li, Y. Y., Qiao, H., Wang, H. C., Yang, X. A., Zhang, H. G., Pang, X. W., Zhang, Y., and Chen, W. F. (2005). TSPY is a cancer testis antigen expressed in human hepatocellular carcinoma. *Br J Cancer* **93**, 458–463.
- Youngren, K. K., Coveney, D., Peng, X., Bhattacharya, C., Schmidt, L. S., Nickerson, M. L., Lamb, B. T., Deng, J. M., Behringer, R. R., Capel, B., *et al.* (2005). The Ter mutation in the dead end gene causes germ cell loss and testicular germ cell tumours. *Nature* **435**, 360–364.
- Zafarana, G., Gillis, A. J. M., van Gurp, R. J. H. L. M., Olsson, P. G., Elstrodt, F., Stoop, H., Millan, J. L., Oosterhuis, J. W., and Looijenga, L. H. J. (2002). Coamplification of DAD-R, SOX5, and EK1 in human testicular seminomas, with specific overexpression of DAD-R, correlates with reduced levels of apoptosis and earlier clinical manifestation. *Cancer Res* **62**, 1822–1831.
- Zafarana, G., Grygalewicz, B., Gillis, A. J. M., Vissers, L. E. L. M., van de Vliet, W., van Gurp, R. J. H. L. M., Stoop, H., Debiec-Rychter, M., Oosterhuis, J. W., Geurts van Kessel, A., *et al.* (2003). 12p-amplicon structure analysis in testicular germ cell tumors of adolescents and adults by array CGH. *Oncogene* **22**, 7695–7701.

CHAPTER 14

ORIGIN OF TESTICULAR GERM CELL NEOPLASIA: THE ROLE OF SEX CHROMOSOMES

Ewa Rajpert-De Meyts, Anne Marie Ottesen, Christina Hoei-Hansen, Si Brask
Sonne, Henrik Leffers, and Niels E. Skakkebaek

*University Department of Growth and Reproduction,
Copenhagen University Hospital (Rigshospitalet),
DK-2100 Copenhagen, Denmark*

Germ cell neoplasms, a cancer type most common in young individuals, are found mainly in the gonads. Testicular tumors in adolescents and young adults are derived from a preinvasive precursor cell called carcinoma *in situ* (CIS) or intratubular germ cell neoplasia, unclassified (ITGCNU). CIS has features of immature fetal germ cells, and is believed to originate from developmentally arrested primordial germ cells or gonocytes. In most cases, the arrest is caused by gonadal dysgenesis, a multifactorial and complex syndrome that has a broad spectrum of phenotypes, ranging from moderate impairment of spermatogenesis to a variety of intersex disorders. Testicular dysgenesis syndrome may be a result of inherited genetic aberrations, but in most cases the pathogenesis is unknown, although it is suspected that genes involved in sex differentiation go through transcriptional or functional deregulation caused by external environmental factors. The effects of these factors are likely modulated by genomic variations (polymorphisms), thus explaining the individual- and population-level differences. In this article, the existing evidence concerning the role of the sex chromosomes is reviewed, with emphasis on aneuploidy and structural aberrations, which carry a high risk of germ cell neoplasia. Less is known about the role of single genes or gene polymorphisms in germ cell development and neoplastic transformation. We hypothesize that factors disturbing gonadal development (including imbalance between the Y and X chromosomes) may lead to impaired germ cell differentiation and prolonged expression of pluripotency genes, and may increase the risk of neoplastic transformation of germ cells.

Keywords: Testicular neoplasms; carcinoma *in situ* testis; testicular; dysgenesis; germ cell tumor; Y chromosome; X chromosome.

Introduction

Germ cell tumors (GCTs) are solid tissue cancers that occur predominantly in young individuals. These tumors are found mainly in the gonads, especially in males, but extragonadal GCTs are not uncommon. The tumors that occur in the testes of young adult males can be divided into two main histological types: seminomas, which are morphologically homogeneous, and nonseminomas. The latter are histologically heterogeneous tumors containing varying proportions of undifferentiated embryonal carcinoma and mixtures of somatic tissues differentiated to a variable degree (teratomas), as well as extraembryonic elements such as choriocarcinoma and yolk sac tumor. Both seminomas and nonseminomas (at times, present together in one testicle as a combined tumor) are derived from a common precursor cell called carcinoma *in situ* (CIS) or intratubular germ cell neoplasia, unclassified (IGCNU) (Skakkebak, 1972; Ulbright *et al.*, 1999). CIS may sometimes occur together with gonadoblastoma (Müller *et al.*, 1992), which is a premalignant lesion of severely dysgenetic and intersex gonads (Scully, 1970).

Since the second half of the 20th century, testicular GCTs (TGCTs) have become increasingly common, but with interesting incidence in terms of geography and ethnicity: white populations in developed countries are most frequently affected by this disease (Clemmesen, 1968; Adami *et al.*, 1994; McKiernan *et al.*, 1999; Huyghe *et al.*, 2003; Richiardi *et al.*, 2004; Purdue *et al.*, 2005). This trend attracted the attention of researchers trying to identify risk factors and elucidate the pathogenesis of TGCTs. A relatively rapid rise in incidence and an epidemiologic link between testicular cancer and other reproductive disorders — such as testicular maldescent, genital malformations, and subfertility — indicated the possible involvement of environmental or lifestyle factors in the etiology of these disorders (Toppari *et al.*, 1996; Skakkebak *et al.*, 1998). More recently, our group has hypothesized that they may be manifestations of a common underlying problem of impaired testicular development, the testicular dysgenesis syndrome (TDS) (Boisen *et al.*, 2001; Skakkebak *et al.*, 2001).

TDS has a spectrum of phenotypes, ranging from slightly decreased testis size with reduced sperm output to severely dysgenetic testis with distorted tubular architecture that may sometimes contain some gonadoblastoma- or ovarian-like structures. The vast majority of testicular

cancers, however, develop in seemingly normal males, and the etiology of the disease remains a mystery. Closer examination of testicular histology, however, reveals that subtle signs of TDS (e.g. undifferentiated Sertoli cells or clusters of small tubules with poorly defined peritubular membranes, sometimes with concentric hyaline bodies inside the tubules) are not uncommon in such patients (Figs. 1B and 1C). These signs of impaired testicular development can be seen in the seemingly normal tissue adjacent to germ cell tumors and in the contralateral testicle without neoplasia (Sohval, 1956; Hoei-Hansen *et al.*, 2003).

Based on the analysis of epidemiological risk factors, clinical observations, and histological findings, we proposed a hypothesis suggesting that even a slight delay in testicular development may play a role in the neoplastic transformation of germ cells (Rajpert-De Meyts *et al.*, 1998). This review discusses the existing evidence concerning the origin of germ cell neoplasia in the testis, with special emphasis on genetic factors and the possible role of the sex chromosomes.

Testis Carcinoma *In Situ* and Gonadoblastoma: Phenotypic Features

Since the first identification of CIS as the precursor of the majority of TGCTs, with the exception of infantile TGCT and spermatocytic seminoma in elderly men (Skakkebak, 1972; Skakkebak *et al.*, 1987), phenotypic features of CIS have been characterized in detail. CIS can be found on the periphery of the majority of TGCTs in young adults (Skakkebak, 1975). Detection of CIS without the presence of a tumor is rare, and only happens in patients undergoing testicular biopsy as part of a subfertility investigation (Skakkebak, 1978; Møller and Skakkebak, 1999). Morphologically, CIS cells resemble fetal gonocytes and occupy the place of spermatogonia in postpubertal testes (Fig. 1).

In prepubertal testes, CIS cells have been identified only sporadically, primarily in individuals with an intersex syndrome (Müller and Skakkebak, 1984; Müller *et al.*, 1985). In the latter, CIS is usually present with gonadoblastoma (Müller *et al.*, 1992). Gonadoblastoma cells appear nearly identical to CIS cells (Fig. 1D), but are arranged in clusters with granulosa-like cells, in contrast to CIS cells which are surrounded by Sertoli cells.

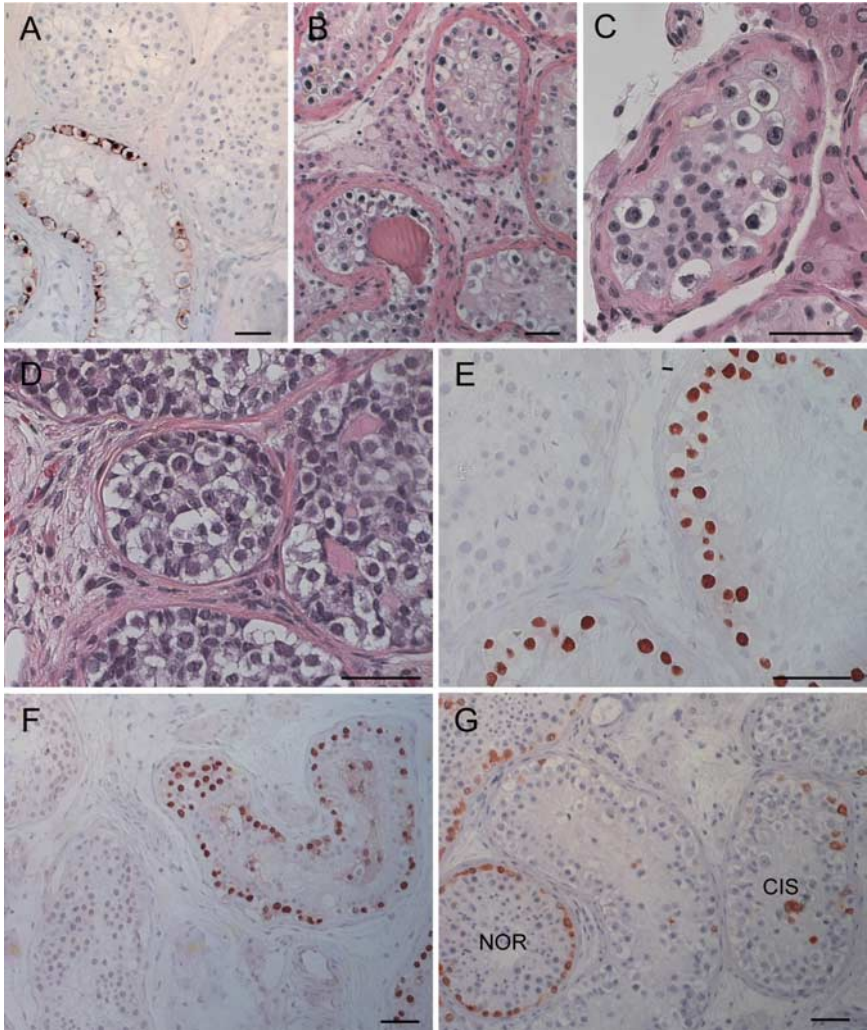

Fig. 1. Histology and phenotypic features of premalignant germ cell lesions, testicular carcinoma *in situ* (CIS), and gonadoblastoma. **A.** General appearance of tubules with and without CIS [marked with placental-like alkaline phosphatase (PLAP) in an adult testis]. **B–C.** CIS occurs frequently in testes with discrete signs of dysgenesis; for example, microcalcifications (microliths) shown in (B) or undifferentiated Sertoli cells (C). **D.** Gonadoblastoma cells morphologically resemble CIS cells, but form poorly defined nests surrounded by somatic cells, similar to primitive granulosa cells. **E.** In contrast to normal spermatogonia, CIS cells express AP-2 γ , a transcription factor associated with the undifferentiated state of numerous cell lineages. **F.** CIS cells express the pluripotency marker NANOG. **G.** Both normal mature spermatogonia and a subpopulation of CIS cells are positive for a testis/cancer antigen, MAGE-A4 (encoded by an X-chromosome gene).

Over the last two decades, a large number of proteins/antigens have been described in CIS cells, and some of them [e.g. placental-like alkaline phosphatase (PLAP); Fig. 1A] have been established as immunohistochemical markers helpful in diagnosing CIS cells (reviewed in Rajpert-De Meyts *et al.*, 2003a). Virtually all of these markers have also been detected in gonadoblastomas (Jørgensen *et al.*, 1997; Kersemaekers *et al.*, 2005). Their presence in fetal gonocytes and, presumably, in primordial germ cells is consistent with the origin of CIS from these cell types (Jørgensen *et al.*, 1995; Rajpert-De Meyts *et al.*, 2003a; Honecker *et al.*, 2004). The presence of some of the highly expressed proteins (e.g. KIT) supported our long-standing hypothesis that CIS may have some stem cell-like features (Rajpert-De Meyts and Skakkebak, 1994; Rajpert-De Meyts and Skakkebak, 2001).

In recent years, with the emergence of new knowledge on the biology of primordial germ cells and embryonic stem cells and with the availability of high-throughput methods of gene expression analysis, it has been demonstrated that CIS cells and a subset of overt GCTs highly express transcription factors associated with pluripotency and self-renewal of embryonic stem cells (Looijenga *et al.*, 2003; Sperger *et al.*, 2003; Almstrup *et al.*, 2004; Clark *et al.*, 2004). Among the transcription factors that are associated with the undifferentiated state are OCT-3/4 (*POU5F1*), NANOG, and AP-2 γ (*TFAP2C*). These proteins are highly abundant in normal fetal pre-meiotic germ cells (primordial germ cells, testicular gonocytes, and ovarian oogonia), and in preinvasive CIS (Figs. 1E and 1F) and gonadoblastoma cells (Hoei-Hansen *et al.*, 2004; Honecker *et al.*, 2004; Jones *et al.*, 2004; Rajpert-De Meyts *et al.*, 2004; Hart *et al.*, 2005; Hoei-Hansen *et al.*, 2005; Kersemaekers *et al.*, 2005; Pauls *et al.*, 2005; Stoop *et al.*, 2005). The high expression of transcription factors associated with pluripotency may explain the capacity of CIS cells to transform into overt tumors with an unlimited variety of somatic differentiation, which is a hallmark of teratomas.

Aneuploidy and Structural Abnormalities of the Y Chromosome

It is now established that there is an association between the aneuploidy of sex chromosomes and an increased risk of germ cell neoplasia. The risk is primarily associated with the intersex syndrome, where there is either

mosaicism for sex chromosome aneuploidy (e.g. 45,X/46,XY), or where the phenotype is predominantly female but the genotype contains some genetic material of the Y chromosome (Schellhas, 1974; Scully, 1981; Troche and Hernandez, 1986; Savage and Lowe, 1990; Peltomäki *et al.*, 1991). These conditions are associated with a high risk of gonadoblastoma and, less frequently, with CIS or more invasive GCTs, usually dysgerminoma or seminoma (Teter *et al.*, 1964; Scully, 1981; Müller *et al.*, 1985; Savage and Lowe, 1990; Slowikowska-Hilczer *et al.*, 2003).

It was proposed that a region of the Y chromosome, which is preserved in gonadoblastomas and is thus named the gonadoblastoma on the Y chromosome (GBY) locus, might harbor an oncogenic gene (Page, 1987). Subsequent studies of this region identified a candidate gene, testis-specific protein on the Y chromosome (TSPY), which was found to be highly expressed in gonadoblastomas, CIS, and seminomas as well as in normal male germ cells (Salo *et al.*, 1995; Tsuchiya *et al.*, 1995; Hildenbrand *et al.*, 1999; Schnieders *et al.*, 1996; Lau *et al.*, 2000; Kersemaekers *et al.*, 2005). The sequence analysis of the human Y chromosome demonstrated that *TSPY* is a multicopy gene (Skaletsky *et al.*, 2003) encoding a protein family (Lau *et al.*, 2003). The possible role of *TSPY* in the development of gonadoblastoma and its progression to more malignant dysgerminoma needs further studies to be corroborated.

One of the first molecular studies of overt TGCTs demonstrated that tumor cells often display a relative loss of the Y chromosome (Peltomäki *et al.*, 1989; Peltomäki *et al.*, 1991). At the same time, studies of infertile men provided evidence that interstitial deletions on the long arm of the Y chromosome (Yq11) are associated with azoospermia or severe failure of spermatogenesis, thus giving the name azoospermia factor (AZF) to this region (Tiepolo and Zuffardi, 1976; Vogt *et al.*, 1992; Reijo *et al.*, 1995). It was subsequently demonstrated that deletions in this region (also called the male-specific region of the Y chromosome, MSY) are facilitated by the presence of long palindromic repeats, known as amplicons (Kuroda-Kawaguchi *et al.*, 2001; Repping *et al.*, 2002; Skaletsky *et al.*, 2003). In addition to large deletions AZFa, AZFb, and AZFc, partial AZFc deletions (e.g. gr/gr, g1/g3, or b2/b3) caused by apparent recombination between smaller amplicons within the AZFc region were detected (Fernandes *et al.*, 2002; Repping *et al.*, 2003; Repping *et al.*, 2004). These deletions are associated with a variable clinical

phenotype and have been described in men with normal spermatogenesis and fertility, thus triggering a debate on the reasons behind the variability.

An important contributing factor is the presence of variable haplogroups of the Y chromosome, which differ among populations and which may affect susceptibility to spermatogenic failure (Jobling and Tyler-Smith, 2003). The associations of some of the Y-chromosome haplogroups with reduced sperm production were found in Japan (Kuroki *et al.*, 1999) and Denmark (Krausz *et al.*, 2001a). Some of the partial AZFc deletions tend to occur in association with certain Y-chromosome lineages, and simultaneous duplication compensating for a deletion may be present in some cases; thus, the final judgment on the pathologic role of partial deletions awaits further studies. A more detailed discussion on the subject of the Y-chromosome variants and deletions as well as male infertility can be found in several excellent recent reviews (Krausz *et al.*, 2004; Vogt, 2005; McElreavey *et al.*, 2006). Given the known association of male subfertility with testicular cancer, an obvious question is whether deletions of genes in the AZF/MSY region of the Y chromosome play a role in the pathogenesis of TGCTs.

Several investigations examined the structural integrity of the Y chromosome in patients with TGCT, both in tumor and germ line DNA. A patient with a germ line microdeletion in the Yq11 region and CIS testis was reported; however, the patient also had mixed gonadal dysgenesis (Papadimas *et al.*, 2001; Papanikolaou *et al.*, 2003), which is frequently associated with germ cell neoplasia. A study of various tissues (mainly tumor tissues) detected mosaic AZF deletions in a surprisingly high proportion (11/15) of Finnish patients with TGCT (Bianchi *et al.*, 2002). A subsequent study by the same group (Richard *et al.*, 2004) found a threefold lower deletion frequency among Norwegian and Argentinean patients. As these deletions were primarily found in tumor tissues, the authors proposed that they were postzygotic, *de novo* events due to the instability of the Y chromosome in testicular cancer (Richard *et al.*, 2004; Bianchi *et al.*, 2006). However, this threefold greater tendency for Y-chromosome instability in Finnish versus Norwegian TGCT patients is difficult to reconcile with the fact that the incidence of TGCT was exactly opposite — it was threefold higher in Norway than in Finland (Adami *et al.*, 1994; Richiardi *et al.*, 2004). It is thought possible that Y-chromosomal instability is a real phenomenon that may lead not only to interstitial deletions, but also to

low-percentage mosaicism for sex chromosome aneuploidy, and could manifest in a subset of patients with testis cancer and infertility (Rajpert-De Meyts *et al.*, 1998; Siffroi *et al.*, 2000; De Palma *et al.*, 2005).

We suspected a possible association of Y-chromosome deletions with a relatively high prevalence of infertility and TGCT in the Danish population; and therefore first assessed the frequency of germ line deletions of the Y chromosome in the Danish population, but found no differences in comparison with other European populations (Krausz *et al.*, 2001b). Subsequently, we examined the frequency of the AZF deletions in the germ line DNA of 160 patients with testicular cancer and found no deletions, suggesting that the majority of sporadic TGCTs do not originate due to the same mechanism as infertility caused by AZF deletions (Frydelund-Larsen *et al.*, 2003). A similar study (Lutke Holzik *et al.*, 2005) was carried out in Dutch patients, and reached a similar conclusion regarding the absence of constitutional AZF deletions in patients with testicular cancer. Likewise, no association between Y lineages and TGCT was found in several populations (Quintana-Murci *et al.*, 2003; Richard *et al.*, 2004; McElreavey and Rajpert-De Meyts, unpublished).

It was, therefore, somewhat surprising that a study of a large series of TGCT cases and controls ($N = 4441$) gathered from 14 countries found an association between a partial AZFc deletion (gr/gr) and TGCT, especially for seminoma (Nathanson *et al.*, 2005). The gr/gr deletion was found in 3% of familial TGCTs, 2% of sporadic cases, and 1.3% of a control group, thus indicating that gr/gr Y-chromosome deletion may confer susceptibility to TGCT (Nathanson *et al.*, 2005). The haplotype analysis of a subset of the cases with gr/gr deletion showed that they were not linked to a specific Y-chromosome haplotype. As the relative risks are not high, it is most likely that partial AZFc deletions only predispose to testicular cancer in the presence of other deleterious factors (e.g. environment- or lifestyle-related factors).

Aneuploidy and Possible Structural Abnormalities of the X Chromosome

When molecular studies of overt TGCTs were initiated, it was noted that tumor cells often display polyploidy or marked amplification of the

X-chromosome material (Peltomäki *et al.*, 1989; Peltomäki *et al.*, 1991). Because of the presence of two copies of the X chromosome in females and only one copy in males, supplemented by some X-derived genes present on the Y chromosome, gene dosage must be very tightly controlled. This control is achieved by inactivation of one of the X chromosomes, with the primary role in this process played by the *XIST* gene, which is transcribed only in individuals with more than one copy of the X chromosome (e.g. in normal females and in males with Klinefelter syndrome) (Plath *et al.*, 2002).

The *XIST* transcript is expressed in CIS cells and in TGCT (Looijenga *et al.*, 1997; Kawakami *et al.*, 2003), probably because of the frequent increase in the copy number of X chromosomes. Klinefelter syndrome, which is the most common chromosomal abnormality in humans (Klinefelter *et al.*, 1942; Jacobs and Strong, 1959), is associated with an increased risk of GCT, but the tumors occur primarily in extragonadal (mediastinal and intracranial) locations and extremely rarely in the testis. The lack of testicular tumors in Klinefelter syndrome may be due to an early depletion of germ cell numbers in developing testes (Coerdt *et al.*, 1985; Aksglæde *et al.*, 2006). In contrast, the supernumerary X chromosome may have an oncogenic effect in early primordial germ cells during their migration, increasing their rate of survival and subsequent malignant transformation in extragonadal locations. Gains of hypomethylated X-chromosome material were reported in intracranial germ cell tumors (Okada *et al.*, 2002). Genes that escape X inactivation are prime suspects for oncogenic effects, and several of these have been implicated in human cancers (Spatz *et al.*, 2004).

An important role for the “female” sex chromosome in male germ cell biology was proposed when it was discovered that a large number of genes on the X chromosome are expressed in male germ cells (Wang *et al.*, 2001; Wang, 2004). At the same time, genomic studies gradually revealed the very complex structure of the X chromosome, which contains numerous large, direct, and inverted segmental duplications and other rearrangements (Small *et al.*, 1997; Giglio *et al.*, 2000; Warburton *et al.*, 2004). This structure was confirmed when the entire X chromosome was sequenced (Ross *et al.*, 2005). It is of particular interest that the repetitive and palindromic sequences are clustered in several distinct regions (e.g. Xq26–28) and contain mainly germ cell-specific genes. One of the regions containing a cluster

of these genes, Xq27, was suspected to contain a germ cell cancer susceptibility gene; but its importance is uncertain due to a simultaneous association with testicular maldescent, which is an independent risk factor for TGCT (Rapley *et al.*, 2000).

Another interesting feature of the X chromosome is the presence of a heterogeneous group of nearly 100 genes, the so-called “cancer/testis antigens” comprising several gene families with conserved sequences (e.g. *MAGE*). These genes are physiologically expressed exclusively in the testis, but their expression is activated in various somatic cancers such as breast cancer and melanoma (Scanlan *et al.*, 2002; Zendman *et al.*, 2003; Warburton *et al.*, 2004; Ross *et al.*, 2005). Two cancer/testis antigens — MAGE-A4 and NY-ESO-1 — were studied in TGCTs and were found abundant in a subset of CIS cells (Fig. 1G) and in the majority of germ cell-derived tumors that retain germ cell morphology, including classical seminomas (MAGE-A4 only) and spermatocytic seminomas, but not in nonseminomas (Jungbluth *et al.*, 2000; Aubry *et al.*, 2001; Yuasa *et al.*, 2001; Satie *et al.*, 2002; Rajpert-De Meyts *et al.*, 2003b). Such a heterogeneous pattern of expression is probably related to differences in genome methylation, but other regulatory mechanisms may also be involved (Koul *et al.*, 2002; Smiraglia *et al.*, 2002; Maio *et al.*, 2003).

We hypothesize that the regions on the X chromosome with repetitive and palindromic sequences may be prone to duplications/interstitial deletions, in analogy to the Y chromosome. In particular, segmental duplications leading to increased dosage of some X-linked genes may render them oncogenic. Alternately, a deletion of an X-linked gene with tumor-suppressing function may also potentially lead to cancer. This area of research is still in its infancy, and the unraveling of the function of testis-specific X-linked genes and their dosage/ploidy in TGCTs will be of great interest.

The Current Understanding of the Origin of Germ Cell Neoplasia

Normal sets of sex chromosomes are indispensable for the normal development of human testes and ovaries. As outlined above, intersex cases with aneuploidy of the sex chromosomes are very important models in which to study the origin of germ cell neoplasia. In the female, the presence of a fragment of the Y chromosome comprising the testis-determining gene, even in

a small subset of cells, would lead to partial masculinization of the gonad. Depending on the relative ploidy of genes/regions on both sex chromosomes, the gonad may develop the whole spectrum of forms between ovary and testis (Fig. 2). According to our observations, CIS occurs preferentially in gonads with decisive testicular differentiation, where only discrete signs of undermasculinization are present.

The role of specific genes remains to be elucidated, but we believe that genes that are expressed in germ cells and gonadal somatic cells are important in this process. However, the latter, especially genes expressed in Sertoli and granulosa cells or their common precursors, may play the primary role. For example, the *SRY* gene plays a key role, as it stimulates differentiation of Sertoli cells and subsequent testis development, with germ cells highly expressing pluripotency genes and prevented from entering meiosis. If there is a mosaic aneuploidy, the signal for testicular development in a part of the gonad will be too weak and some parts may have difficulty forming normal sex cords, resulting in the appearance of nests of gonadoblastomas. The role

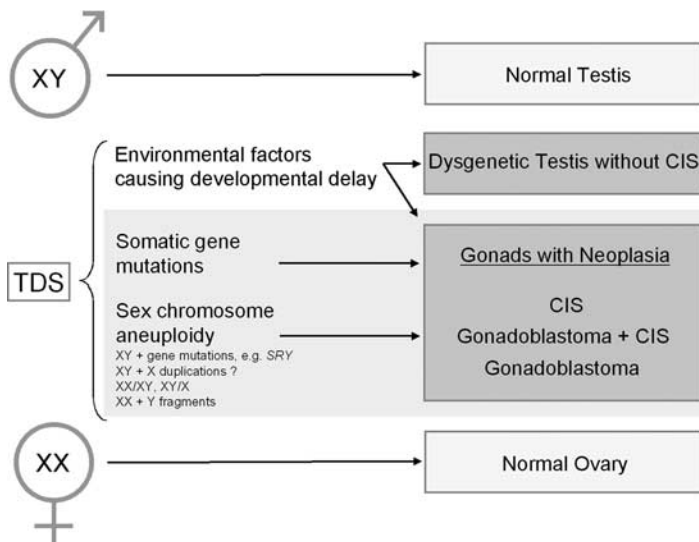

Fig. 2. A schematic depiction of factors involved in the origin of premalignant changes in gonads, carcinoma *in situ* (CIS), and gonadoblastoma. Genetic factors, including partial or complete aneuploidy of the sex chromosomes as well as somatic mutations, are highlighted in light gray. Environmental factors, which are presumed to influence the majority of sporadic cases of testicular dysgenesis syndrome (TDS), are also shown.

of *TSPY* and the importance of a copy number of this multicopy gene remain to be elucidated. It is possible that this gene is oncogenic, as it stimulates the proliferation of germ cells, thus increasing their odds of survival. However, *TSPY* does not function in female primordial germ cells, which are also capable of forming tumors (e.g. germinomas) in the central nervous system (Hoei-Hansen *et al.*, 2006). As discussed earlier in this review, it is possible that X-linked genes, if amplified (e.g. due to segmental duplication), may also function as oncogenes in the absence of the Y chromosome.

The sex chromosomes and their genetic aberrations, however, are only a part of the story. Numerous somatic genes play an important role in gonadal development and germ cell differentiation, and in the pathogenesis of at least some cases of germ cell neoplasia. These genes are not discussed here because of the focus of this review on sex chromosomes, but should not be forgotten. Finally, in the majority of cases of CIS and TGCT, no genetic abnormality in constitutive DNA can be detected, at least by currently available means. Undetected point mutations in single genes definitely play a role in a subset of these cases, but the remaining cases are most likely caused by functional deregulation of pathways involved in fetal development of the testis.

The existence of numerous causal factors is supported by a very broad spectrum of conditions and disorders associated with the presence of CIS and TDS. A few cases of TDS are indeed caused by aberrations of the sex chromosomes, but the majority is linked to the adverse influence of environmental factors during fetal development, as clearly indicated by epidemiological trends (Skakkebak *et al.*, 1998; Weir *et al.*, 2000; Skakkebak *et al.*, 2001; Rajpert-De Meyts, 2006). In conclusion, we believe that the key event for the initiation of neoplastic transformation of germ cells is a delay of early gonadal development, which disturbs and inhibits germ cell differentiation and may ultimately lead to cancer.

Acknowledgments

We thank several colleagues who participated in some of the studies outlined here; in particular, Lone Frydelund-Larsen. The studies of the Copenhagen group summarized in this review were supported by the Danish Cancer Society, Svend Andersen's Foundation, Kirsten and Freddy Johansen's Foundation, Carla Thiel's Foundation, and the Vissing Foundation.

References

- Adami, H., Bergström, R., Möhner, M., Zatonski, W., Storm, H., Ekblom, A., Tretli, S., Teppo, L., Ziegler, H., Rahu, M., *et al.* (1994). Testicular cancer in nine northern European countries. *Int J Cancer* **59**, 33–38.
- Aksglæde, L., Wikström, A. M., Rajpert-De Meyts, E., Dunkel, L., Skakkebaek, N. E., and Juul, A. (2006). Natural history of seminiferous tubule degeneration in Klinefelter syndrome. *Hum Reprod Update* **12**, 39–48.
- Almstrup, K., Hoei-Hansen, C. E., Wirkner, U., Blake, J., Schwager, C., Ansoerge, W., Nielsen, J. E., Skakkebaek, N. E., Rajpert-De Meyts, E., and Leffers, H. (2004). Embryonic stem cell-like features of testicular carcinoma in situ revealed by genome-wide gene expression profiling. *Cancer Res* **64**, 4736–4743.
- Aubry, F., Satie, A.-P., Rioux-Leclercq, N., Rajpert-De Meyts, E., Spagnoli, G. C., Chomez, P., De Backer, O., Jegou, B., and Samson, M. (2001). *MAGE-A4*, a germ-cell specific marker, is expressed differentially in testicular tumors. *Cancer* **92**, 2778–2785.
- Bianchi, N. O., Richard, S. M., and Pavicic, M. S. (2006). Y chromosome instability in testicular cancer. *Mutat Res* **612**, 172–178.
- Bianchi, N. O., Richard, S. M., Peltomäki, P., and Bianchi, M. S. (2002). Mosaic AZF deletions and susceptibility to testicular tumors. *Mutat Res* **503**, 51–62.
- Boisen, K. A., Main, K. M., Rajpert-De Meyts, E., and Skakkebaek, N. E. (2001). Are male reproductive disorders a common entity? The testicular dysgenesis syndrome. *Ann N Y Acad Sci* **948**, 90–99.
- Clark, A. T., Rodriguez, R. T., Bodnar, M. S., Abeyta, M. J., Cedars, M. I., Turek, P. J., Firpo, M. T., and Reijo Pera, R. A. (2004). Human STELLAR, NANOG, and GDF3 genes are expressed in pluripotent cells and map to chromosome 12p13, a hotspot for teratocarcinoma. *Stem Cells* **22**, 169–179.
- Clemmesen, J. (1968). A doubling of morbidity from testis carcinoma in Copenhagen, 1943–1962. *Acta Pathol Microbiol Scand* **72**, 348–349.
- Coerdts, W., Rehder, H., Gausmann, I., Johannisson, R., and Gropp, A. (1985). Quantitative histology of human fetal testes in chromosomal disease. *Pediatr Pathol* **3**, 245–259.
- De Palma, A., Burrello, N., Barone, N., D'Agata, R., Vicari, E., and Calogero, A. E. (2005). Patients with abnormal sperm parameters have an increased sex chromosome aneuploidy rate in peripheral leukocytes. *Hum Reprod* **20**, 2153–2156.
- Fernandes, S., Huellen, K., Goncalves, J., Dukal, H., Zeisler, J., Rajpert-De Meyts, E., Skakkebaek, N. E., Habermann, B., Krause, W., Sousa, M., *et al.* (2002). High frequency of *DAZ1/DAZ2* gene deletions in patients with severe oligozoospermia. *Mol Hum Reprod* **8**, 286–298.
- Frydelund-Larsen, L., Vogt, P., Leffers, H., Schadwinkel, A., Daugaard, G., Skakkebaek, N. E., and Rajpert-De Meyts, E. (2003). No AZF deletion in 160 patients with testicular germ cell cancer. *Mol Hum Reprod* **9**, 517–521.
- Giglio, S., Pirola, B., Arrigo, G., Dagrada, P., Bardoni, B., Bernardi, F., Russo, G., Argentiero, L., Forabosco, A., Carozzo, R., and Zuffardi, O. (2000). Opposite deletions/duplications of the X chromosome: two novel reciprocal rearrangements. *Eur J Hum Genet* **8**, 63–70.
- Hart, A. H., Hartley, L., Parker, K., Ibrahim, M., Looijenga, L. H., Pauchnik, M., Chow, C. W., and Robb, L. (2005). The pluripotency homeobox gene NANOG is expressed in human germ cell tumors. *Cancer* **104**, 2092–2098.

- Hildenbrand, R., Schroder, W., Brude, E., Schepler, A., König, R., Stutte, H. J., and Arnemann, J. (1999). Detection of TSPY protein in a unilateral microscopic gonadoblastoma of a Turner mosaic patient with a Y-derived marker chromosome. *J Pathol* **189**, 623–626.
- Hoei-Hansen, C. E., Almstrup, K., Nielsen, J. E., Brask, S. S., Graem, N., Skakkebaek, N. E., Leffers, H., and Rajpert-De Meyts, E. (2005). Stem cell pluripotency factor NANOG is expressed in human fetal gonocytes, testicular carcinoma *in situ* and germ cell tumours. *Histopathology* **47**, 48–56.
- Hoei-Hansen, C. E., Holm, M., Rajpert-De Meyts, E., and Skakkebaek, N. E. (2003). Histological evidence of testicular dysgenesis in contralateral biopsies of 218 patients with testicular germ cell cancer. *J Pathol* **200**, 370–374.
- Hoei-Hansen, C. E., Nielsen, J. E., Almstrup, K., Brask, S. S., Graem, N., Skakkebaek, N. E., Leffers, H., and Rajpert-De Meyts, E. (2004). Transcription factor AP-2 γ is a developmentally regulated marker of testicular carcinoma *in situ* and germ cell tumors. *Clin Cancer Res* **10**, 8521–8530.
- Hoei-Hansen, C. E., Sehested, A., Juhler, M., Lau, Y. F., Skakkebaek, N. E., Laursen, H., and Rajpert-De Meyts, E. (2006). New evidence for the origin of intracranial germ cell tumors from primordial germ cells: expression of pluripotency and cell differentiation markers. *J Pathol* **209**, 25–33.
- Honecker, F., Stoop, H., de Krijger, R. R., Lau, Y.-F. C., Bokemeyer, C., and Looijenga, L. H. (2004). Pathobiological implications of the expression of markers of testicular carcinoma *in situ* by fetal germ cells. *J Pathol* **203**, 849–857.
- Huyghe, E., Matsuda, T., and Thonneau, P. (2003). Increasing incidence of testicular cancer worldwide: a review. *J Urol* **170**, 5–11.
- Jacobs, P. A., and Strong, J. A. (1959). A case of human intersexuality having a possible XXY sex-determining mechanism. *Nature* **183**, 302–303.
- Jobling, M. A., and Tyler-Smith, C. (2003). The human Y chromosome: an evolutionary marker comes of age. *Nat Rev Genet* **4**, 598–612.
- Jones, T. D., Ulbright, T. M., Eble, J. N., and Cheng, L. (2004). OCT4: a sensitive and specific biomarker for intratubular germ cell neoplasia of the testis. *Clin Cancer Res* **10**, 8544–8547.
- Jørgensen, N., Müller, J., Jaubert, F., Clausen, O. P., and Skakkebaek, N. E. (1997). Heterogeneity of gonadoblastoma germ cells: similarities with immature germ cells, spermatogonia and testicular carcinoma *in situ* cells. *Histopathology* **30**, 177–186.
- Jørgensen, N., Rajpert-De Meyts, E., Graem, N., Müller, J., Giwercman, A., and Skakkebaek, N. E. (1995). Expression of immunohistochemical markers for testicular carcinoma *in situ* by normal human fetal germ cells. *Lab Invest* **72**, 223–231.
- Jungbluth, A. A., Busam, K. J., Kolb, D., Iversen, K., Coplan, K., Chen, Y. T., Spagnoli, G. C., and Old, L. J. (2000). Expression of MAGE-antigens in normal tissues and cancer. *Int J Cancer* **85**, 460–465.
- Kawakami, T., Okamoto, K., Sugihara, H., Hattori, T., Reeve, A. E., Ogawa, O., and Okada, Y. (2003). The roles of supernumerical X chromosomes and XIST expression in testicular germ cell tumors. *J Urol* **169**, 1546–1552.
- Kersemaekers, A. M., Honecker, F., Stoop, H., Cools, M., Molier, M., Wolffenbuttel, K., Bokemeyer, C., Li, Y., Lau, Y. F., Oosterhuis, J. W., and Looijenga, L. H. J. (2005).

- Identification of germ cells at risk for neoplastic transformation in gonadoblastoma: an immunohistochemical study for OCT3/4 and TSPY. *Hum Pathol* **36**, 512–521.
- Klinefelter, H. F., Reifenstein, E. C., and Albright, F. (1942). Syndrome characterized by gynecomastia, aspermatogenesis without a-Leydigism, and increased excretion of follicle-stimulating hormone. *J Clin Endocrinol* **2**, 615–627.
- Koul, S., Houldsworth, J., Mansukhani, M. M., Donadio, A., McKiernan, J. M., Reuter, V. E., Bosl, G. J., Chaganti, R. S., and Murty, V. V. (2002). Characteristic promoter hypermethylation signatures in male germ cell tumors. *Mol Cancer* **1**, 8 (online publication).
- Krausz, C., Quintana-Murci, L., and Forti, G. (2004). Y chromosome polymorphisms in medicine. *Ann Med* **36**, 573–583.
- Krausz, C. G., Quintana-Murci, L., Rajpert-De Meyts, E., Jørgensen, N., Jobling, M., Rosser, Z. H., Skakkebaek, N. E., and McElreavey, K. (2001a). Identification of a Y chromosome haplogroup associated with reduced sperm counts. *Hum Mol Genet* **10**, 1873–1877.
- Krausz, C. G., Rajpert-De Meyts, E., Frydelund-Larsen, L., Quintana-Murci, L., McElreavey, K., and Skakkebaek, N. E. (2001b). Double-blind Y chromosome microdeletion analysis in men with known sperm parameters and reproductive hormone profiles. *J Clin Endocrinol Metab* **86**, 2638–2642.
- Kuroda-Kawaguchi, T., Skaletsky, H., Brown, L. G., Minx, P. J., Cordum, H. S., Waterston, R. H., Wilson, R. K., Silber, S., Oates, R., Rozen, S., and Page, D. C. (2001). The AZFc region of the Y chromosome features massive palindromes and uniform recurrent deletions in infertile men. *Nat Genet* **29**, 279–286.
- Kuroki, Y., Iwamoto, T., Lee, J., Yoshiike, M., Nozawa, S., Nishida, T., Ewis, A. A., Nakamura, H., Toda, T., Tokunaga, K., *et al.* (1999). Spermatogenic ability is different among males in different Y chromosome lineage. *J Hum Genet* **44**, 289–292.
- Lau, Y. F., Chou, P. M., Iezzoni, J. C., Alonzo, J. A., and Kömüves, L. G. (2000). Expression of a candidate gene for the gonadoblastoma locus in gonadoblastoma and testicular seminoma. *Cytogenet Cell Genet* **91**, 160–164.
- Lau, Y. F., Lau, H. W., and Kömüves, L. G. (2003). Expression pattern of a gonadoblastoma candidate gene suggests a role of the Y chromosome in prostate cancer. *Cytogenet Genome Res* **101**, 250–260.
- Looijenga, L. H. J., Gillis, A. J. M., van Gurp, R. J. H. L. M., Verkerk, A. J. M. H., and Oosterhuis, J. W. (1997). X inactivation in human testicular tumors. XIST expression and androgen receptor methylation status. *Am J Pathol* **151**, 581–590.
- Looijenga, L. H. J., Stoop, H., de Leeuw, P. J. C., de Gouveia Brazao, C. A., Gillis, A. J. M., van Roozendaal, K. E., van Zoelen, E. J., Weber, R. F., Wolffenbittel, K. P., van Dekken, H., *et al.* (2003). POU5F1 (OCT3/4) identifies cells with pluripotent potential in human germ cell tumors. *Cancer Res* **63**, 2244–2250.
- Lutke Holzik, M. F., Storm, K., Sijmons, R. H., D'Hollander, M., Arts, E. G., Verstraaten, M. L., Sleijfer, D. T., and Hoekstra, H. J. (2005). Absence of constitutional Y chromosome AZF deletions in patients with testicular germ cell tumors. *Urology* **65**, 196–201.
- Maior, M., Coral, S., Fratta, E., Altomonte, M., and Sigalotti, L. (2003). Epigenetic targets for immune intervention in human malignancies. *Oncogene* **22**, 6484–6488.
- McElreavey, K., Ravel, C., Chantot-Bastaraud, S., and Siffroi, J. P. (2006). Y chromosome variants and male reproductive function. *Int J Androl* **29**, 298–303.

- McKiernan, J. M., Goluboff, E. T., Liberson, G. L., Golden, R., and Fisch, H. (1999). Rising risk of testicular cancer by birth cohort in the United States from 1973 to 1995. *J Urol* **162**, 361–363.
- Møller, H., and Skakkebaek, N. E. (1999). Risk of testicular cancer in subfertile men: case-control study. *Br Med J* **318**, 559–562.
- Müller, J., and Skakkebaek, N. E. (1984). Testicular carcinoma in situ in children with androgen insensitivity (testicular feminisation) syndrome. *Br Med J* **288**, 1419–1420.
- Müller, J., Skakkebaek, N. E., Ritzén, E. M., Plöen, L., and Petersen, K. E. (1985). Carcinoma in situ of the testis in children with 45,X/46,XY gonadal dysgenesis. *J Pediatr* **106**, 431–436.
- Müller, J., Visfeldt, J., Philip, J., and Skakkebaek, N. E. (1992). Carcinoma in situ, gonadoblastoma, and early invasive neoplasia in a nine-year-old girl with 46,XY gonadal dysgenesis. *APMIS* **100**, 170–174.
- Nathanson, K. L., Kanetsky, P. A., Hawes, R., Vaughn, D. J., Letrero, R., Tucker, K., Friedlander, M., Phillips, K. A., Hogg, D., Jewett, M. A., et al. (2005). The Y deletion *gr/gr* and susceptibility to testicular germ cell tumor. *Am J Hum Genet* **77**, 1034–1043.
- Okada, Y., Nishikawa, R., Matsutani, M., and Louis, D. N. (2002). Hypomethylated X chromosome gain and rare isochromosome 12p in diverse intracranial germ cell tumors. *J Neuropathol Exp Neurol* **61**, 531–538.
- Page, D. C. (1987). Hypothesis: a Y-chromosomal gene causes gonadoblastoma in dysgenetic gonads. *Development* **101**(Suppl), 151–155.
- Papadimas, J., Goulis, D. G., Giannouli, C., Papanicolaou, A., Tarlatzis, B., and Bontis, J. N. (2001). Ambiguous genitalia, 45,XY/46,XY mosaic karyotype, and Y chromosome microdeletions in a 17-year-old man. *Fertil Steril* **76**, 1261–1263.
- Papanikolaou, A. D., Goulis, D. G., Giannouli, C., Gounioti, C., Bontis, J. N., and Papadimas, J. (2003). Intratubular germ cell neoplasia in a man with ambiguous genitalia, 45,X/46,XY mosaic karyotype, and Y chromosome microdeletions. *Endocr Pathol* **14**, 177–182.
- Pauls, K., Jager, R., Weber, S., Wardelmann, E., Koch, A., Buttner, R., and Schorle, H. (2005). Transcription factor AP-2 gamma, a novel marker of gonocytes and seminomatous germ cell tumours. *Int J Cancer* **115**, 470–477.
- Peltomäki, P., Halme, A., and de la Chapelle, A. (1989). Molecular studies of the sex chromosomes in human testicular cancer: pronounced changes in X and Y chromosome dosage in some tumors. *Genes Chromosomes Cancer* **1**, 42–47.
- Peltomäki, P., Lothe, R., Borresen, A. L., Fosså, S. D., Brogger, A., and de la Chapelle, A. (1991). Altered dosage of the sex chromosomes in human testicular cancer: a molecular genetic study. *Int J Cancer* **47**, 518–522.
- Plath, K., Mlynarczyk-Evans, S., Nusinov, D. A., and Panning, B. (2002). Xist RNA and the mechanism of X chromosome inactivation. *Annu Rev Genet* **36**, 233–278.
- Purdue, M. P., Devesa, S. S., Sigurdson, A. J., and McGlynn, K. A. (2005). International patterns and trends in testis cancer incidence. *Int J Cancer* **115**, 822–827.
- Quintana-Murci, L., Weale, M. E., Thomas, M. G., Erdei, E., Bradman, N., Shanks, J. H., Krausz, C. G., and McElreavey, K. (2003). Y-chromosome haplotypes and testicular cancer in the English population. *J Med Genet* **40**, e20.
- Rajpert-De Meyts, E. (2006). Developmental model for the pathogenesis of testicular carcinoma in situ: genetic and environmental aspects. *Hum Reprod Update* **12**, 303–323.

- Rajpert-De Meyts, E., Bartkova, J., Samson, M., Hoei-Hansen, C. E., Frydelund-Larsen, L., Bartek, J., and Skakkebaek, N. E. (2003a). The emerging phenotype of the testicular carcinoma in situ germ cell. *APMIS* **111**, 267–279.
- Rajpert-De Meyts, E., Hanstein, R., Jorgensen, N., Graem, N., Vogt, P. H., and Skakkebaek, N. E. (2004). Developmental expression of POU5F1 (OCT-3/4) in normal and dysgenetic human gonads. *Hum Reprod* **19**, 1338–1344.
- Rajpert-De Meyts, E., Jacobsen, G. K., Bartkova, J., Aubry, F., Samson, M., Bartek, J., and Skakkebaek, N. E. (2003b). The immunohistochemical expression pattern of Chk2, p19INK4d, p53, MAGE-A4 and other selected antigens provides new evidence for the premeiotic origin of spermatocytic seminoma. *Histopathology* **42**, 1–10.
- Rajpert-De Meyts, E., Jørgensen, N., Brøndum-Nielsen, K., Müller, J., and Skakkebaek, N. E. (1998). Developmental arrest of germ cells in the pathogenesis of germ cell neoplasia. *APMIS* **106**, 198–206.
- Rajpert-De Meyts, E., and Skakkebaek, N. E. (1994). Expression of the c-kit protein product in carcinoma in situ and invasive germ cell tumours. *Int J Androl* **17**, 85–92.
- Rajpert-De Meyts, E., and Skakkebaek, N. E. (2001). Biology of testicular carcinoma *in situ*, the stem-cell like precursor of germ cell cancer. In: *Andrology in the 21st Century*, B. Robaire, H. Chemes, & C. R. Morales, eds., Medimond, New York, pp. 409–417.
- Rapley, E. A., Crockford, G. P., Teare, D., Biggs, P., Seal, S., Barfoot, R., Edwards, S., Hamoudi, R., Heimdal, K., Fosså, S. D., *et al.* (2000). Localization to Xq27 of a susceptibility gene for testicular germ-cell tumours. *Nat Genet* **24**, 197–200.
- Reijo, R., Lee, T. Y., Salo, P., Alagappan, R., Brown, L. G., Rosenberg, M., Rozen, S., Jaffe, T., Straus, D., Hovatta, O., *et al.* (1995). Diverse spermatogenic defects in humans caused by Y chromosome deletions encompassing a novel RNA-binding protein gene. *Nat Genet* **10**, 383–393.
- Repping, S., Skaletsky, H., Brown, L., van Daalen, S. K., Korver, C. M., Pyntikova, T., Kuroda-Kawaguchi, T., de Vries, J. W., Oates, R. D., Silber, S., *et al.* (2003). Polymorphism for a 1.6-Mb deletion of the human Y chromosome persists through balance between recurrent mutation and haploid selection. *Nat Genet* **35**, 247–251.
- Repping, S., Skaletsky, H., Lange, J., Silber, S., van der Veen, F., Oates, R. D., Page, D. C., and Rozen, S. (2002). Recombination between palindromes P5 and P1 on the human Y chromosome causes massive deletions and spermatogenic failure. *Am J Hum Genet* **71**, 906–922.
- Repping, S., van Daalen, S. K., Korver, C. M., Brown, L., Marszalek, J., Gianotten, J., Oates, R. D., Silber, S., van der Veen, F., Page, D. C., and Rozen, S. (2004). A family of human Y chromosomes has dispersed throughout northern Eurasia despite a 1.8-Mb deletion in the AZFc region. *Genomics* **83**, 1046–1052.
- Richard, S. M., Bianchi, N. O., Bianchi, M. S., Peltomäki, P., Lothe, R. A., and Pavicic, W. (2004). Ethnic variation in the prevalence of AZF deletions in testicular cancer. *Mutat Res* **554**, 45–51.
- Richiardi, L., Bellocco, R., Adami, H. O., Torrang, A., Barlow, L., Hakulinen, T., Rahu, M., Stengrevics, A., Storm, H., Tretli, S., *et al.* (2004). Testicular cancer incidence in eight northern European countries: secular and recent trends. *Cancer Epidemiol Biomarkers Prev* **13**, 2157–2166.
- Ross, M. T., Grafham, D. V., Coffey, A. J., Scherer, S., McLay, K., Muzny, D., Platzer, M., Howell, G. R., Burrows, C., Bird, C. P., *et al.* (2005). The DNA sequence of the human X chromosome. *Nature* **434**, 325–337.

- Salo, P., Kaariainen, H., Petrovic, V., Peltomaki, P., Page, D. C., and de la Chapelle, A. (1995). Molecular mapping of the putative gonadoblastoma locus on the Y chromosome. *Genes Chromosomes Cancer* **14**, 210–214.
- Satie, A.-P., Rajpert-De Meyts, E., Spagnoli, G. C., Henno, S., Olivo, L., Jacobsen, G. K., Rioux-Leclercq, N., Jegou, B., and Samson, M. (2002). The cancer-testis gene, *NY-ESO-1*, is expressed in normal fetal and adult testes and in spermatocytic seminoma and testicular carcinoma in situ. *Lab Invest* **82**, 775–780.
- Savage, M. O., and Lowe, D. G. (1990). Gonadal neoplasia and abnormal sexual differentiation. *Clin Endocrinol* **32**, 519–533.
- Scanlan, M. J., Gure, A. O., Jungbluth, A. A., Old, L. J., and Chen, Y. T. (2002). Cancer/testis antigens: an expanding family of targets for cancer immunotherapy. *Immunol Rev* **188**, 22–32.
- Schellhas, H. F. (1974). Malignant potential of the dysgenetic gonad. *Obstet Gynecol* **44**, 298–309.
- Schnieders, F., Dörk, T., Arnemann, J., Vogel, T., Werner, M., and Schmidtke, J. (1996). Testis-specific protein, Y-encoded (TSPY) expression in testicular tissues. *Hum Mol Genet* **5**, 1801–1807.
- Scully, R. E. (1970). Gonadoblastoma. A review of 74 cases. *Cancer* **25**, 1340–1356.
- Scully, R. E. (1981). Neoplasia associated with anomalous sexual development and abnormal sex chromosomes. *Pediatr Adolesc Endocrinol* **8**, 203–217.
- Siffroi, J. P., Le Bourhis, C., Krausz, C., Barboux, S., Quintana-Murci, L., Kanafani, S., Rouba, H., Bujan, L., Bourrouillou, G., Seifer, I., et al. (2000). Sex chromosome mosaicism in males carrying Y chromosome long arm deletions. *Hum Reprod* **15**, 2559–2562.
- Skakkebak, N. E. (1972). Possible carcinoma-in-situ of the testis. *Lancet* **2**, 516–517.
- Skakkebak, N. E. (1975). Atypical germ cells in the adjacent 'normal' tissue of testicular tumours. *APMIS* **83**, 127–130.
- Skakkebak, N. E. (1978). Carcinoma in situ of the testis: frequency and relationship to invasive germ cell tumours in infertile men. *Histopathology* **2**, 157–170.
- Skakkebak, N. E., Berthelsen, J. G., Giwercman, A., and Müller, J. (1987). Carcinoma-in-situ of the testis: possible origin from gonocytes and precursor of all types of germ cell tumours except spermatocytoma. *Int J Androl* **10**, 19–28.
- Skakkebak, N. E., Rajpert-De Meyts, E., Jørgensen, N., Carlsen, E., Petersen, P. M., Giwercman, A., Andersen, A. G., Jensen, T. K., Andersson, A.-M., and Müller, J. (1998). Germ cell cancer and disorders of spermatogenesis: an environmental connection? *APMIS* **106**, 3–12.
- Skakkebak, N. E., Rajpert-De Meyts, E., and Main, K. M. (2001). Testicular dysgenesis syndrome: an increasingly common developmental disorder with environmental aspects. *Hum Reprod* **16**, 972–978.
- Skaletsky, H., Kuroda-Kawaguchi, T., Minx, P., Cordum, H., Hillier, L., Brown, L., Repping, S., Pyntikova, T., Ali, J., Bieri, T., et al. (2003). The male-specific region of the human Y chromosome is a mosaic of discrete sequence classes. *Nature* **423**, 825–837.
- Slowikowska-Hilczler, J., Romer, T. E., and Kula, K. (2003). Neoplastic potential of germ cells in relation to disturbances of gonadal organogenesis and changes in karyotype. *J Androl* **24**, 270–278.

- Small, K., Iber, J., and Warren, S. T. (1997). Emerin deletion reveals a common X-chromosome inversion mediated by inverted repeats. *Nat Genet* **16**, 96–99.
- Smiraglia, D. J., Szymanska, J., Kraggerud, S. M., Lothe, R. A., Peltomaki, P., and Plass, C. (2002). Distinct epigenetic phenotypes in seminomatous and nonseminomatous testicular germ cell tumors. *Oncogene* **21**, 3909–3916.
- Sohval, A. R. (1956). Testicular dysgenesis in relation to neoplasm of the testicle. *J Urol* **75**, 285–291.
- Spatz, A., Borg, C., and Feunteun, J. (2004). X-chromosome genetics and human cancer. *Nat Rev Cancer* **4**, 617–629.
- Sperger, J. M., Chen, X., Draper, J. S., Antosiewicz, J. E., Chon, C. H., Jones, S. B., Brooks, J. D., Andrews, P. W., Brown, P. O., and Thomson, J. A. (2003). Gene expression patterns in human embryonic stem cells and human pluripotent germ cell tumors. *Proc Natl Acad Sci U S A* **100**, 13350–13355.
- Stoop, H., Honecker, F., Cools, M., de Krijger, R., Bokemeyer, C., and Looijenga, L. H. (2005). Differentiation and development of human female germ cells during prenatal gonadogenesis: an immunohistochemical study. *Hum Reprod* **20**, 1466–1476.
- Teter, J., Philip, J., and Wecewicz, G. (1964). ‘Mixed’ gonadal dysgenesis with gonadoblastoma in situ. *Am J Obstet Gynecol* **90**, 929–935.
- Tiepolo, L., and Zuffardi, O. (1976). Localization of factors controlling spermatogenesis in the nonfluorescent portion of the human Y chromosome long arm. *Hum Genet* **34**, 119–124.
- Toppiari, J., Larsen, J. C., Christiansen, P., Giwercman, A., Grandjean, P., Guillette, L. J., Jr., Jégou, B., Jensen, T. K., Jouannet, P., Keiding, N., *et al.* (1996). Male reproductive health and environmental xenoestrogens. *Environ Health Perspect.* **104**(Suppl 4), 741–803.
- Troche, V., and Hernandez, E. (1986). Neoplasia arising in dysgenetic gonads. *Obstet Gynecol Surv* **41**, 74–79.
- Tsuchiya, K., Reijo, R., Page, D. C., and Disteché, C. M. (1995). Gonadoblastoma: molecular definition of the susceptibility region on the Y chromosome. *Am J Hum Genet* **57**, 1400–1407.
- Ulbricht, T. M., Amin, M. B., and Young, R. H. (1999). *Atlas of Tumor Pathology: Tumors of the Testis, Adnexa, Spermatic Cord, and Scrotum*, Armed Forces Institute of Pathology, Washington, DC, pp. 1–385.
- Vogt, P. H. (2005). AZF deletions and Y chromosomal haplogroups: history and update based on sequence. *Hum Reprod Update* **4**, 319–336.
- Vogt, P. H., Chandley, A. C., Hargreave, T. B., Keil, R., Ma, K., and Sharkey, A. (1992). Microdeletions in interval 6 of the Y chromosome of males with idiopathic sterility points to disruption of AZF, a human spermatogenesis gene. *Hum Genet* **89**, 491–496.
- Wang, P. J. (2004). X chromosomes, retrogenes and their role in male reproduction. *Trends Endocrinol Metab* **15**, 79–83.
- Wang, P. J., McCarrey, J. R., Yang, F., and Page, D. C. (2001). An abundance of X-linked genes expressed in spermatogonia. *Nat Genet* **27**, 422–426.
- Warburton, P. E., Giordano, J., Cheung, F., Gelfand, Y., and Benson, G. (2004). Inverted repeat structure of the human genome: the X-chromosome contains a preponderance of large, highly homologous inverted repeats that contain testes genes. *Genome Res* **14**, 1861–1869.

- Weir, H. K., Marrett, L. D., Kreiger, N., Darlington, G. A., and Sugar, L. (2000). Pre-natal and peri-natal exposures and risk of testicular germ-cell cancer. *Int J Cancer* **87**, 438–443.
- Yuasa, T., Okamoto, K., Kawakami, T., Mishina, M., Ogawa, O., and Okada, Y. (2001). Expression patterns of cancer testis antigens in testicular germ cell tumors and adjacent testicular tissue. *J Urol* **165**, 1790–1794.
- Zendman, A. J., Zschocke, J., van Kraats, A. A., de Wit, N. J., Kurpisz, M., Weidle, U. H., Ruiter, D. J., Weiss, E. H., and van Muijen, G. N. (2003). The human SPANX multigene family: genomic organization, alignment and expression in male germ cells and tumor cell lines. *Gene* **309**, 125–133.

AUTHOR INDEX

Bernard, P. 47
Braydich-Stolle, L. 149
Burgoyne, P. S. 1, 27
Chan, W.-Y. 201
DePamphilis, M. L. 185
Ditton, H.-J. 91
Dobrinski, I. 235
Dym, M. 221
Harley, V. R. 47
He, Z. 221
Hoei-Hansen, C. 289
Hofmann, M.-C. 149
Kamp, C. 91
Kaneko, K. J. 185
Kido, T. 73
Kohn, M. J. 185
Lau, Y.-F. C. 73
Lee, T.-L. 201
Leffers, H. 289
Li, Y. 73
Litscher, E. S. 185
Looijenga, L. H. J. 263
Mitchell, M. J. 1
Ottesen, A. M. 289
Rajpert-De Meyts, E. 289
Rennert, O. M. 201
Ruszczuk, L. 201
Skakkebæk, N. E. 289
Sonne, S. B. 289
Stahle, M. I. 47
Turner, J. M. A. 27
Vogt, P. H. 91
Wassarman, P. M. 185
Wu, S.-M. 201
Yagi, R. 185
Yanagimachi, R. 255
Yen, P. 127
Zimmer, J. 91

This page intentionally left blank

INDEX

- ATR*, 27, 31, 32, 34
AZF, 128, 129
BOULE, 127, 134–139
BRCA1, 27, 31, 32, 34
DAX-1, 52, 53, 63
DAZ, 277
DAZ-like, 134
DBX, 91, 100, 106–111
DBY, 91, 100, 101, 106–111, 114, 115, 117
DHH, 53
Eif2s3y, 1, 2, 4, 14, 15, 17–20, 25
OCT3/4-POU5F1, 263, 272–275, 278, 279
Prm1, 208, 210, 211
Prm2, 208, 209, 211
Rbmy, 3–7, 10, 277
SF-1, 52, 63
SOX9, 52, 58, 63
SRY, 299
Tead2, 185, 186, 190–193
TSPX and *TSPY* expression, 78–80, 85, 86
TSPY, 269, 274, 277–279, 281, 294, 300
USP9X, 91, 100, 102, 103–106
USP9Y, 91, 100–106, 110, 114, 115
UTX, 91, 100, 111–113
UTY, 91, 99, 100, 110–115
WNT4, 54
WT1, 53
- acrosome, 185, 191, 193–197
animal models, 278
antiparallel genes, 213
antisense transcripts
 function, 204, 205, 212, 213
 stage-specific expression, 208
 structural groups, 209
assisted fertilization
 in vitro fertilization (IVF), 257
 intracytoplasmic sperm injection (ICSI), 255, 257–260
 round spermatid injection (ROSI), 259, 260
azoospermia factor (AZF) locus, 92–94
- biological function, 130, 137, 141
bivalent, 11–13, 16, 17
brain-derived neurotrophic factor (BDNF)
 and receptors, 151–156
- c-kit, 221, 226, 227, 238–240, 242
c-kit receptor, 221, 226
calmodulin 2 (*Calm2*), 208, 211, 212
carcinoma *in situ* (CIS), 79, 80, 263, 264, 266, 268, 270, 274, 275, 278, 279, 289–295, 297–300
cell cycle, 73, 76, 78, 79, 81, 84
cell isolation, 224, 226, 229, 231
cell proliferation, 78, 79, 161, 168, 169
chaperonin 10 (*Ch10*), 208, 211, 212
chromosome mapping, 81
ciliary neurotrophic factor (CNTF), 157–162
cloning, 255, 261
coculture, 240
- deleted in azoospermia (*DAZ*), 128, 130, 132–141
deletion, 1–3, 5–11, 14, 16, 18, 19, 92–94, 97–101, 104, 105, 109–111, 117
deletion mapping, 91, 92, 94, 97
development regulation, 186
diagnostic markers, 266, 268, 272
Dickkopf-like 1 (*Dkk1*), 185, 186, 189–197
DNA-bending, 49, 51, 57, 58
DNA-binding, 47, 49–51, 57, 58, 61, 62
dysgenetic gonads, 115

- embryogenesis, 93–95, 104, 108, 114, 115
 embryonic stem cells, 113
- fertilization, 255–258
 fibroblast growth factor (FGF), 151, 167, 172
- gametogenesis, 138
 GDNF, 221, 226
 gene and protein structure, 128, 132
 gene deletion, 128, 133, 134, 136, 141
 gene duplication, 133–135
 gene expression, 129–131, 136–141
 gene organization, 186
 gene structures and functions, 101, 106, 111
 genetic engineering, 221, 223, 229
 genomic structure, 97, 99
 germ cell culture, 239
 germ cell epigenetics, 29
 germ cell neoplasia, 289, 290, 295
 origin, 291, 298–300
 germ cell transplantation, 235–244, 246–248
 germ cell tumors, 290, 291, 297
 GFR α 1, 164, 165, 167–169, 171, 221, 226–228
 glial cell line-derived neurotrophic factor (GDNF) family of receptors (GFR), 151, 163–172
 gonadal development, 48, 49
 gonadal dysgenesis, 47, 50, 53, 54, 57, 58
 gonadoblastoma, 73–76, 115, 116, 290, 291
 gonadoblastoma locus on the Y chromosome (GBY), 74, 75
 gonadoblastoma Y locus (GBY), 115, 116
- H2AX phosphorylation, 30–33
 heterochromatin protein, 61
 high-mobility group (HMG) box, 47, 49–52, 54, 55, 57–60
 histone H2AX, 27
 histone modifications, 30, 31, 34, 38
- Hoechst 33342, 230
 Hoechst efflux, 230, 231
 HY antigen, 91, 114–116
- infertility, 8
 inner cell mass (ICM), 190, 191
 intergenic sequence, 201, 211, 213
 interleukin-11 (IL-11), 157, 161, 162
 interleukin-6 (IL-6), 157, 161
 intratubular germ cell neoplasia unclassified (ITGCNU), 263, 266, 268, 270, 274, 275, 278, 279
 introns, 202, 212, 213
- knockout, 149, 153, 156, 164
 Kruppel-associated box only (KRAB-O), 50, 59–63
- lactate dehydrogenase 3, C chain (*Ldh3C*), 208–210
 leukemia inhibitory factor (LIF), 157–163, 171
- male germ cells, 237, 240, 244, 245
 male infertility, 99, 127
 mammalian development, 188, 190, 192, 196
 mast cell growth factor, 226
 meiotic sex chromosome inactivation (MSCI), 27–39
 meiotic silencing, 27, 33, 35, 39
 meiotic silencing by unpaired DNA (MSUD), 35–37
 meiotic silencing of unsynapsed chromatin (MSUC), 27, 34–38, 40
 mouse, 1–5, 7, 9–12, 14, 15, 17–19, 28, 34, 35, 37, 38
- nerve growth factor (NGF) and receptors, 151–153, 157
 neuropoietic cytokines, 149, 151, 157, 158, 161–163

- neurotrophic factors, 149, 151, 153, 159, 163, 164, 172
 neurotrophin receptors, 151, 152, 155–157
 neurotrophin-3 (NT-3) and receptors, 151, 152, 154–156
 neurotrophin-4/5 (NT-4/5) and receptors, 152, 155, 156
 neurotrophins, 149, 151, 152, 155–157
 non-PAR Y long arm (NPYq), 3–5, 7–12
 nuclear import, 49, 59
 nuclear localization signals, 47, 49, 58, 59

 omnipotency, 272
 oncostatin M (OSM), 157, 158, 160–162
 oocyte, 255, 257–261

 p75^{NTR} receptor, 152, 155–157
 pachytene checkpoint, 27, 36, 37
 pachytene spermatocyte, 207, 211
 phenotypic features, 291, 292
 postmeiotic sex chromosome inactivation (PSCI), 38, 39
 premalignant germ cell, 292
 primordial germ cells, 94, 95, 102, 104–106
 procollagen I (Coll1a1), 227, 228
 protein interaction, 59–61
 protein structure, 193, 194
 proto-X, 83, 84
 proto-Y, 83, 84
 pseudoautosomal region (PAR), 2–5, 8, 12–14, 16, 17
 pseudogenes, 209, 211–214

 recombination, 1, 2, 5, 17
 Ret tyrosine kinase, 166
 retrotransposition, 83, 84
 RNA-binding motif Y (*RBMY*), 128
 RNA-dependent RNA polymerase (RdRP), 35, 210
 RNA-induced silencing complex (RISC), 35
 round spermatid, 207

 seminoma, 75, 80
 sense and antisense transcripts (SATs), 201, 202, 204–207
 serial analysis of gene expression (SAGE), 201, 203
 Sertoli cell-only syndrome, 91, 93–98, 111
 SET/NAP domain, 73, 76–79, 81, 83–85
 sex body, 29–31, 34, 36, 39
 sex chromosome evolution, 83
 sex chromosome univalence, 11, 13, 14, 16
 sex chromosomes, 3, 11–14, 16, 27–29, 31, 32, 34, 36
 sex determination, 47, 48, 50–54, 58, 60, 61, 63
 sex reversal, 5, 47, 51–56, 58
 sex-determining genes, 51, 52, 54, 62, 63
 sex-determining region Y (SRY) gene, 47
 side population, 230
 signal transduction, 156, 162, 166
 sperm, 258–260
 sperm defects, 5, 9, 10
 sperm-borne oocyte-activating factor (SOAF), 258, 259
 spermatogenesis, 1–3, 5, 7, 12, 15–20, 27, 28, 30, 91, 93, 97, 100, 101, 105, 110, 111, 114, 116, 127, 128, 134, 135, 139, 149–151, 153, 160–164, 166, 168, 170, 172, 173, 185, 193, 194, 201, 206–208, 211, 213, 214
 spermatogenic defects, 235, 240, 241
 spermatogonia, 149, 150, 153, 154, 157, 159, 161, 162, 165–171, 221, 222, 225–228
 spermatogonial proliferation, 1, 2, 14, 15
 spermatogonial stem cells, 221, 223, 224, 226–229, 231, 235–240, 248
 type A, 222, 225–228
 type B, 222, 227
 spermatogonial/tissue transplantation applications, 243
 spermatogoniogenesis, 93–96
 spermiogenesis, 1, 5, 12, 16, 18, 28, 29, 37–39
 spindle checkpoint, 2, 12, 13, 16
 STAPUT procedure, 225, 229
 steel factor, 226

- stem cell factor (SCF), 221, 226, 229
stem cell niche, 238, 239, 248
stem cells, 149, 150, 158, 159, 163–172,
221–224, 226, 228–231, 235–240, 247,
248
synthetic sex cells, 228
- T-complex–associated testis expressed 3
(Tcte3), 208–210
tandem repeat gene, 73, 75
targeted gene disruption, 155, 156, 160
TEA domain (Tead) transcription factor,
190
testicular dysgenesis syndrome (TDS),
289–291, 299, 300
testicular germ cell tumors (TGCTs), 290,
291, 294–298, 300
array CGH, 270
candidate genes
c-kit, 270
DMRT1, 272
Dnd, 269
classification, 265
embryonic stem cell, 270
genomic imprinting, 266, 267
nonseminoma, 263, 265–267,
269–273
origin, 263, 264, 266, 267, 272, 275,
280
pathogenesis, 263, 264, 267, 268,
272, 278
risk factors, 263, 268, 277, 280
seminoma, 263–267, 270–275,
277–280
spermatocytic seminoma, 263–267,
271, 272, 277, 278, 280
teratoma, 263–267, 269, 272, 273,
280
yolk sac tumor, 263–267, 269, 272,
273, 279, 280
- testis tissue transplantation, 235, 243, 246
testis-specific protein Y-encoded (TSPY)
gene, 73–81, 83–86
tissue grafting, 247
transgenic mice, 166
TrkA, 152, 153, 156, 157
TrkB, 152–155
TrkC, 152, 154–156
trophoblast, 185, 190, 191, 196
TSPX, 73, 77–81, 83–85
TSPY-like genes, 73, 76, 81, 83–86
type A spermatogonium, 207, 211, 212
- ubiquitin A-52 residue ribosomal protein
fusion product 1 (*Uba52*), 208, 211, 212
ubiquitin B (*Ubb*), 208, 211
- Wingless (Wnt) signal transduction, 185
- X and Y chromosome
aneuploidy, 289, 293, 294, 296, 298,
299
deletion, 294–296, 298
structural abnormalities, 293, 296
X inactivation, 297
- X and Y transcriptional silencing, 29, 34,
35, 38, 39
- X chromosome inactivation (XCI), 27, 29,
37–39
- X–Y homologous genes, 115
- xenogeneic germ cell transplantation,
242–245, 247
- xenograft, 235, 244–247
- Y chromosome, 1–5, 7, 8, 14, 15, 47, 49,
91–95, 97–100, 102, 110, 269, 275, 277,
278, 281
- Y chromosome microdeletion, 128