

2008 EDITION

ANSI/AF&PA SDPWS-2008

Approval Date: AUGUST 4, 2008

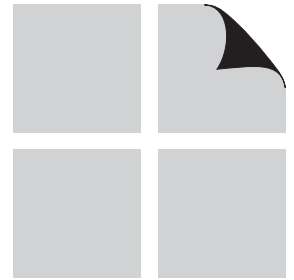

ASD/LRFD

WIND & SEISMIC

**SPECIAL DESIGN PROVISIONS
FOR WIND AND SEISMIC**

WITH COMMENTARY

**American
Forest &
Paper
Association**

American Wood Council

Updates and Errata

While every precaution has been taken to ensure the accuracy of this document, errors may have occurred during development.

Updates or Errata are posted to the American Wood Council website at www.awc.org.

Technical inquiries may be addressed to awcinfo@afandpa.org.

The American Wood Council (AWC) is the wood products division of the American Forest & Paper Association (AF&PA). AF&PA is the national trade association of the forest, paper, and wood products industry, representing member companies engaged in growing, harvesting, and processing wood and wood fiber; manufacturing pulp, paper, and paperboard products from both virgin and recycled fiber; and producing engineered and traditional wood products. For more information see www.afandpa.org.

2008 EDITION

ANSI/AF&PA SDPWS-2008

Approval Date: AUGUST 4, 2008

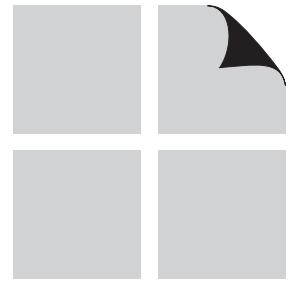

ASD/LRFD

WIND & SEISMIC

**SPECIAL DESIGN PROVISIONS
FOR WIND AND SEISMIC**

WITH COMMENTARY

Special Design Provisions for Wind and Seismic with Commentary 2008 Edition

June 2009 Web Version

ISBN 0-9786245-9-9

Copyright © 2009 by American Forest & Paper Association, Inc.

All rights reserved. No part of this publication may be reproduced, distributed, or transmitted in any form or by any means, including, without limitation, electronic, optical, or mechanical means (by way of example and not limitation, photocopying, or recording by or in an information storage retrieval system) without express written permission of the American Forest & Paper Association, Inc. For information on permission to copy material, please contact:

Copyright Permission

AF&PA American Wood Council
1111 Nineteenth St., NW, Suite 800
Washington, DC 20036
email: awcinfo@afandpa.org

Printed in the United States of America

TABLE OF CONTENTS

<i>Chapter/Title</i>	<i>Page</i>	<i>Chapter/Title</i>	<i>Page</i>
1 Designer Flowchart	1	4 Lateral Force-Resisting Systems	11
1.1 Flowchart		4.1 General	
2 General Design Requirements	3	4.2 Wood-Frame Diaphragms	
2.1 General		4.3 Wood-Frame Shear Walls	
2.2 Terminology		4.4 Wood Structural Panels Designed to Resist Combined Shear and Uplift from Wind	
2.3 Notation		Appendix A	41
3 Members and Connections	7	References	43
3.1 Framing		Commentary	45
3.2 Sheathing			
3.3 Connections			

LIST OF TABLES

3.1.1.1 Wall Stud Repetitive Member Factors	8	4.3.4 Maximum Shear Wall Aspect Ratios	25
3.2.1 Nominal Uniform Load Capacities (psf) for Wall Sheathing Resisting Out-of-Plane Wind Loads	9	4.3A Nominal Unit Shear Capacities for Wood-Frame Shear Walls (Wood-based Panels)	31
3.2.2 Nominal Uniform Load Capacities (psf) for Roof Sheathing Resisting Out-of-Plane Wind Loads	10	4.3B Nominal Unit Shear Capacities for Wood-Frame Shear Walls (Wood Structural Panels Applied over 1/2" or 5/8" Gypsum Wallboard or Gypsum Sheathing Board)	32
4.2.4 Maximum Diaphragm Aspect Ratios (Horizontal or Sloped Diaphragms)	14	4.3C Nominal Unit Shear Capacities for Wood-Frame Shear Walls (Gypsum and Portland Cement Plaster)	33
4.2A Nominal Unit Shear Capacities for Wood-Frame Diaphragms (Blocked Wood Structural Panel Diaphragms)	18	4.3D Nominal Unit Shear Capacities for Wood-Frame Shear Walls (Lumber Shear Walls) ...	34
4.2B Nominal Unit Shear Capacities for Wood-Frame Diaphragms (Blocked Wood Structural Panel Diaphragms Utilizing Multiple Rows of Fasteners (High Load Diaphragms))	19	4.4.1 Nominal Uplift Capacity of 7/16" Minimum Wood Structural Panel Sheathing or Siding When Used for Both Shear Walls and Wind Uplift Simultaneously over Framing with a Specific Gravity of 0.42 or Greater	39
4.2C Nominal Unit Shear Capacities for Wood-Frame Diaphragms (Unblocked Wood Structural Panel Diaphragms)	20	4.4.2 Nominal Uplift Capacity of 3/8" Minimum Wood Structural Panel Sheathing or Siding When Used for Wind Uplift Only over Framing with a Specific Gravity of 0.42 or Greater	39
4.2D Nominal Unit Shear Capacities for Wood-Frame Diaphragms (Lumber Diaphragms) ..	21	A1 Standard, Common, Box, and Sinker Nails ..	42
4.3.3.2 Unblocked Shear Wall Adjustment Factor, C_{ub}	23	A2 Standard Cut Washers	42
4.3.3.5 Shear Capacity Adjustment Factor, C_o	24		

LIST OF FIGURES

4A	Open Front Structure.....	14	4G	Panel Attachment.....	36
4B	Cantilevered Building.....	15	4H	Panel Splice Occurring over Horizontal Framing Member.....	37
4C	High Load Diaphragm.....	17	4I	Panel Splice Occurring across Stud.....	37
4D	Typical Shear Wall Height-to-Width Ratio for Perforated Shear Walls.....	25	4J	Sheathing Splice Plate (Alternate Detail).....	38
4E	Typical Individual Full-Height Wall Segments Height-to-Width Ratio.....	26			
4F	Typical Shear Wall Height-to-Width Ratio for Shear Walls Designed for Force Transfer Around Openings.....	26			

LIST OF COMMENTARY TABLES

C3.2A	Wood Structural Panel Dry Design Bending Strength Capacities.....	50	C4.2.2C	Relationship Between Span Rating and Nominal Thickness.....	57
C3.2B	Wood Structural Panel Dry Shear Capacities in the Plane.....	50	C4.2.2D	Fastener Slip, e_n (in.).....	57
C3.2C	Cellulosic Fiberboard Sheathing Design Bending Strength Capacities.....	50	C4.2.2E	Data Summary for Blocked and Unblocked Wood Structural Panel Diaphragms.....	58
C4.2.2A	Shear Stiffness, $G_v t_v$ (lb/in. of depth), for Wood Structural Panels.....	55	C4.2.2F	Data Summary for Horizontal Lumber and Diagonal Lumber Sheathed Diaphragms....	58
C4.2.2B	Shear Stiffness, $G_v t_v$ (lb/in. of depth), for Other Sheathing Materials.....	55	C4.3.2A	Data Summary for Structural Fiberboard, Gypsum Wallboard, and Lumber Sheathed Shear Walls.....	66

LIST OF COMMENTARY FIGURES

C4.2.2-3a	Diaphragm Dimensions and Shear and Moment Diagram.....	59	C4.3.3	Detail for Adjoining Panel Edges where Structural Panels are Applied to Both Faces of the Wall.....	69
C4.2.2-3b	Diaphragm Chord, Double Top Plate with Two Joints in Upper Plate.....	59	C4.3.6.4.3	Distance for Plate Washer Edge to Sheathed Edge.....	71
C4.2.7.1.1	Diaphragm Cases 1 through 6.....	63	C4.4.1.7(1)	Panel Splice Over Common Horizontal Framing Member.....	74
C4.2.7.1.1(3)	Staggering of Nails at Panel Edges of Blocked Diaphragms.....	63	C4.4.1.7(2)	Detail for Continuous Panel Between Levels (Load Path for Shear Transfer Into and Out of the Diaphragm Not Shown).....	75
C4.3.2	Comparison of 4-Term and 3-Term Deflection Equations.....	65			

DESIGNER FLOWCHART

1.1 Flowchart

2

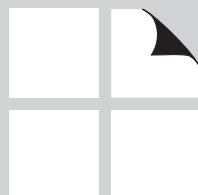

1.1 Flowchart

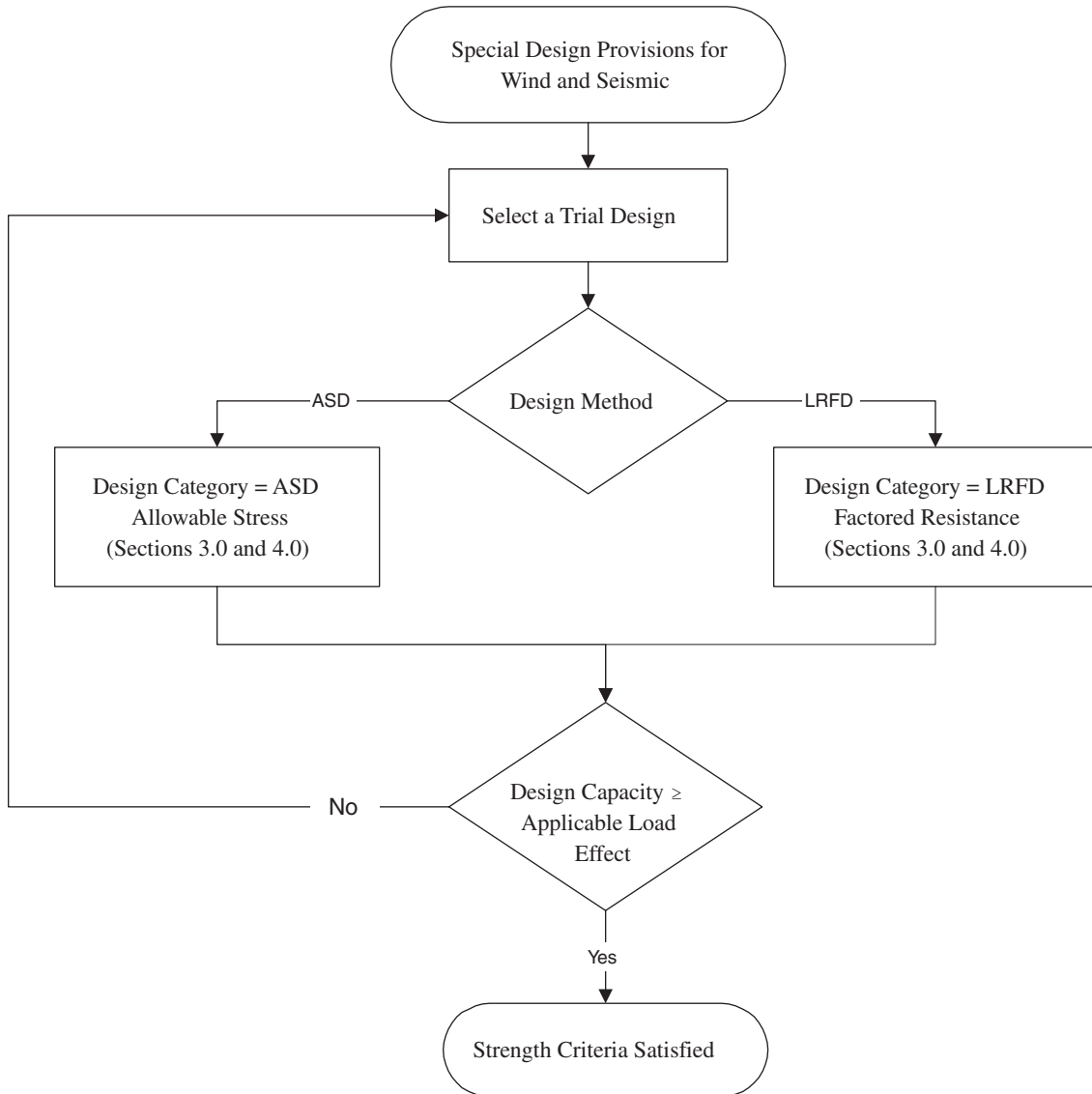

GENERAL DESIGN REQUIREMENTS

2.1	General	4
2.2	Terminology	4
2.3	Notation	6

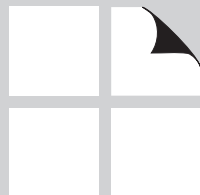

2.1 General

2.1.1 Scope

The provisions of this document cover materials, design and construction of wood members, fasteners, and assemblies to resist wind and seismic forces.

2.1.2 Design Methods

Engineered design of wood structures to resist wind and seismic forces shall be by one of the methods described in 2.1.2.1 and 2.1.2.2.

Exception: Wood structures shall be permitted to be constructed in accordance with prescriptive provisions permitted by the authority having jurisdiction.

2.1.2.1 Allowable Stress Design: Allowable stress design (ASD) shall be in accordance with the *National Design Specification*[®] (*NDS*[®]) for Wood Construction (ANSI/AF&PA NDS-05) and provisions of this document.

2.1.2.2 Strength Design: Load and resistance factor design (LRFD) of wood structures shall be in accordance with the *National Design Specification (NDS) for Wood Construction* (ANSI/AF&PA NDS-05) and provisions of this document.

2.2 Terminology

ALLOWABLE STRESS DESIGN. A method of proportioning structural members and their connections such that stresses do not exceed specified allowable stresses when the structure is subjected to appropriate load combinations (also called working stress design).

ASD REDUCTION FACTOR. A factor to reduce nominal strength to an allowable stress design level.

BOUNDARY ELEMENT. Diaphragm and shear wall boundary members to which sheathing transfers forces. Boundary elements include chords and collectors at diaphragm and shear wall perimeters, interior openings, discontinuities, and re-entrant corners.

CHORD. A boundary element perpendicular to the applied load that resists axial stresses due to the induced moment.

COLLECTOR. A diaphragm or shear wall element parallel and in line with the applied force that collects and transfers diaphragm shear forces to the vertical elements of the lateral-force-resisting system and/or distributes forces within the diaphragm.

COMPOSITE PANELS. A wood structural panel comprised of wood veneer and reconstituted wood-based material bonded together with a waterproof adhesive.

DIAPHRAGM. A roof, floor, or other membrane bracing system acting to transmit lateral forces to the vertical resisting elements. When the term “diaphragm” is used, it includes horizontal bracing systems.

DIAPHRAGM, BLOCKED. A diaphragm in which all adjacent panel edges are fastened to either common framing members or common blocking.

DIAPHRAGM, FLEXIBLE. A diaphragm is flexible for the purpose of distribution of story shear when the computed maximum in-plane deflection of the diaphragm itself under lateral load is greater than two times the average deflection of adjoining vertical elements of the lateral force resisting system of the associated story under equivalent tributary lateral load.

DIAPHRAGM, RIGID. A diaphragm is rigid for the purpose of distribution of story shear and torsional moment when the computed maximum in-plane deflection of the diaphragm itself under lateral load is less than or equal to two times the average deflection of adjoining vertical elements of the lateral force-resisting system of the associated story under equivalent tributary lateral load. For analysis purposes, it can be assumed that a rigid diaphragm distributes story shear and torsional moment into lines of shear walls by the relative lateral stiffness of the shear walls.

DIAPHRAGM BOUNDARY. A location where shear is transferred into or out of the diaphragm sheathing. Transfer is either to a boundary element or to another force-resisting element.

DIAPHRAGM, UNBLOCKED. A diaphragm that has fasteners at boundaries and supporting members only. Blocking between supporting structural members at panel edges is not included.

FIBERBOARD. A fibrous, homogeneous panel made from lignocellulosic fibers (usually wood or cane) and having a density of less than 31 pounds per cubic foot but more than 10 pounds per cubic foot.

FORCE-TRANSFER SHEAR WALL. A shear wall with openings in the wall that has been specifically designed and detailed for force transfer around the openings.

HARDBOARD. A fibrous-felted, homogeneous panel made from lignocellulosic fibers consolidated under heat and pressure in a hot press to a density not less than 31 pounds per cubic foot.

LATERAL STIFFNESS. The inverse of the deformation of shear walls under an applied unit load, or the force required to deform a shear wall a unit distance.

LOAD AND RESISTANCE FACTOR DESIGN (LRFD). A method of proportioning structural members and their connections using load and resistance factors such that no applicable limit state is reached when the structure is subjected to appropriate load combinations.

NOMINAL STRENGTH. Strength of a member, cross section, or connection before application of any strength reduction factors.

ORIENTED STRAND BOARD. A mat-formed wood structural panel product composed of thin rectangular wood strands or wafers arranged in oriented layers and bonded with waterproof adhesive.

PARTICLEBOARD. A generic term for a panel primarily composed of cellulosic materials (usually wood), generally in the form of discrete pieces or particles, as distinguished from fibers. The cellulosic material is combined with synthetic resin or other suitable bonding system by a process in which the interparticle bond is created by the bonding system under heat and pressure.

PERFORATED SHEAR WALL. A shear wall with openings in the wall that has not been specifically de-

signed and detailed for force transfer around wall openings, and meets the requirements of 4.3.5.3.

PERFORATED SHEAR WALL SEGMENT. A section of a perforated shear wall with full height sheathing that meets the requirements for maximum aspect ratio limits in 4.3.4.

PLYWOOD. A wood structural panel comprised of plies of wood veneer arranged in cross-aligned layers. The plies are bonded with an adhesive that cures on application of heat and pressure.

REQUIRED STRENGTH. Strength of a member, cross section, or connection required to resist factored loads or related internal moments and forces.

RESISTANCE FACTOR. A factor that accounts for deviations of the actual strength from the nominal strength and the manner and consequences of failure.

SEISMIC DESIGN CATEGORY. A classification assigned to a structure based on its Seismic Use Group (see building code) and the severity of the design earthquake ground motion at the site.

SHEAR WALL. A wall designed to resist lateral forces parallel to the plane of a wall.

SHEAR WALL, BLOCKED. A shear wall in which all adjacent panel edges are fastened to either common framing members or common blocking.

SHEAR WALL, UNBLOCKED. A shear wall that has fasteners at boundaries and vertical framing members only. Blocking between vertical framing members at adjacent panel edges is not included.

SHEAR WALL LINE. A series of shear walls in a line at a given story level.

TIE-DOWN (HOLD DOWN). A device used to resist uplift of the chords of shear walls.

WALL PIER. A section of wall adjacent to an opening and equal in height to the opening, which is designed to resist lateral forces in the plane of the wall according to the force-transfer method (4.3.5.2).

WOOD STRUCTURAL PANEL. A panel manufactured from veneers; or wood strands or wafers; or a combination of veneer and wood strands or wafers; bonded together with waterproof synthetic resins or other suitable bonding systems. Examples of wood structural panels are plywood, oriented strand board (OSB), or composite panels.

2.3 Notation

A = area, in. ²	h = height of a shear wall or shear wall segment, ft, measured as:
C = compression chord force, lbs	1. maximum clear height from top of foundation to bottom of diaphragm framing above, ft, or
C_o = shear capacity adjustment factor	2. maximum clear height from top of diaphragm below to bottom of diaphragm framing above, ft
E = modulus of elasticity, psi	t = uniform uplift force, lbs/ft
G = specific gravity	v = induced unit shear, lbs/ft
G_a = apparent shear stiffness from nail slip and panel shear deformation, kips/in.	v_{max} = maximum induced unit shear force, lbs/ft
G_{ac} = combined apparent shear wall shear stiffness of two-sided shear wall, kips/in.	v_s = nominal unit shear capacity for seismic design, lbs/ft
G_{a1} = apparent shear wall shear stiffness for side 1, kips/in.	v_{sc} = combined nominal unit shear capacity of two-sided shear wall for seismic design, lbs/ft
G_{a2} = apparent shear wall shear stiffness for side 2, kips/in.	v_{s1} = nominal unit shear capacity for designated side 1, lbs/ft
K_{min} = minimum ratio of v_1/G_{a1} or v_2/G_{a2}	v_{s2} = nominal unit shear capacity for designated side 2, lbs/ft
L = dimension of a diaphragm in the direction perpendicular to the application of force and is measured as the distance between vertical elements of the lateral-force-resisting system (in many cases, this will match the sheathed dimensions), ft. For open front structures, L is the length from the edge of the diaphragm at the open front to the vertical resisting elements parallel to the direction of the applied force, ft	v_w = nominal unit shear capacity for wind design, lbs/ft
L_c = length of the cantilever for a cantilever diaphragm, ft	v_{wc} = combined nominal unit shear capacity of two-sided shear wall for wind design, lbs/ft
ΣL_i = sum of perforated shear wall segment lengths, ft	x = distance from chord splice to nearest support, ft
R = response modification coefficient	Δ_a = total vertical elongation of wall anchorage system (including fastener slip, device elongation, rod elongation, etc.), in., at the induced unit shear in the shear wall
T = tension chord force, lbs	Δ_c = diaphragm chord splice slip at the induced unit shear in diaphragm, in.
V = induced shear force in perforated shear wall, lbs	δ_{dia} = maximum diaphragm deflection determined by elastic analysis, in.
W = dimension of a diaphragm in the direction of application of force and is measured as the distance between diaphragm chords, ft (in many cases, this will match the sheathed dimension)	δ_{sw} = maximum shear wall deflection determined by elastic analysis, in.
b = length of a shear wall or shear wall segment measured as the sheathed dimension of the shear wall or segment, ft	ϕ_b = sheathing resistance factor for out-of-plane bending
b_s = length of a shear wall or shear wall segment for determining aspect ratio, ft. For perforated shear walls, use the minimum shear wall segment length included in the ΣL_i . For force-transfer shear walls, see 4.3.4.2.	ϕ_z = resistance factor for connections
	ϕ_D = sheathing resistance factor for in-plane shear of shear walls and diaphragms
	Ω_0 = system overstrength factor

MEMBERS AND CONNECTIONS

3.1	Framing	8
3.2	Sheathing	8
3.3	Connections	10
	Table 3.1.1.1 Wall Stud Repetitive Member Factors.....	8
	Table 3.2.1 Nominal Uniform Load Capacities (psf) for Wall Sheathing Resisting Out-of-Plane Wind Loads.....	9
	Table 3.2.2 Nominal Uniform Load Capacities (psf) for Roof Sheathing Resisting Out-of-Plane Wind Loads.....	10

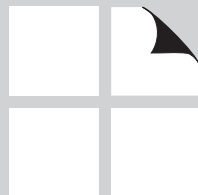

3.1 Framing

3.1.1 Wall Framing

In addition to gravity loads, wall framing shall be designed to resist induced wind and seismic forces. The framing shall be designed using the methods referenced in 2.1.2.1 for allowable stress design (ASD) and 2.1.2.2 for strength design (LRFD).

3.1.1.1 Wall Stud Bending Design Value Increase: The reference bending design value, F_b , for sawn lumber wood studs resisting out-of-plane wind loads shall be permitted to be increased by the repetitive member factors in Table 3.1.1.1, in lieu of the NDS repetitive member factor, $C_r=1.15$. The repetitive member factors in Table 3.1.1.1 apply when studs are designed for bending, spaced no more than 16" on center, covered on the inside with a minimum of 1/2" gypsum wall-board, attached in accordance with minimum building code requirements and sheathed on the exterior with a minimum of 3/8" wood structural panel sheathing with all panel joints occurring over studs or blocking and attached using a minimum of 8d common nails spaced a maximum of 6" on center at panel edges and 12" on center at intermediate framing members.

Table 3.1.1.1 Wall Stud Repetitive Member Factors

Stud Size	System Factor
2x4	1.50
2x6	1.35
2x8	1.25
2x10	1.20
2x12	1.15

3.2 Sheathing

3.2.1 Wall Sheathing

Exterior wall sheathing and its fasteners shall be capable of resisting and transferring wind loads to the wall framing. Maximum spans and nominal uniform load capacities for wall sheathing materials are given in Table 3.2.1. The ASD allowable uniform load capacities to be used for wind design shall be determined by

3.1.2 Floor Framing

In addition to gravity loads, floor framing shall be designed to resist induced wind and seismic forces. The framing shall be designed using the methods referenced in 2.1.2.1 for allowable stress design (ASD) and 2.1.2.2 for strength design (LRFD).

3.1.3 Roof Framing

In addition to gravity loads, roof framing shall be designed to resist induced wind and seismic forces. The framing shall be designed using the methods referenced in 2.1.2.1 for allowable stress design (ASD) and 2.1.2.2 for strength design (LRFD).

dividing the nominal uniform load capacities in Table 3.2.1 by an ASD reduction factor of 1.6. The LRFD factored uniform load capacities to be used for wind design shall be determined by multiplying the nominal uniform load capacities in Table 3.2.1 by a resistance factor, ϕ_b , of 0.85. Sheathing used in shear wall assemblies to resist lateral forces shall be designed in accordance with 4.3.

Table 3.2.1 Nominal Uniform Load Capacities (psf) for Wall Sheathing Resisting Out-of-Plane Wind Loads¹

Sheathing Type ³	Span Rating or Grade	Minimum Thickness (in.)	Strength Axis ⁵							
			Perpendicular to Supports				Parallel to Supports			
			Maximum Stud Spacing (in.)	Actual Stud Spacing (in.)			Maximum Stud Spacing (in.)	Actual Stud Spacing (in.)		
				12	16	24		12	16	24
			Nominal Uniform Loads (psf)			Nominal Uniform Loads (psf)				
Wood Structural Panels (Sheathing Grades, C-C, C-D, C-C Plugged, OSB) ⁴	24/0	3/8	24	425	240	105	24	90	50	25 ²
	24/16	7/16	24	540	305	135	24	110	60	25 ²
	32/16	15/32	24	625	355	155	24	155	90	40 ²
	40/20	19/32	24	955	595	265	24	255	145	65 ²
	48/24	23/32	24	1160	805	360	24	380	215	95 ²
Particleboard Sheathing (M-S Exterior Glue)		3/8	16	(contact manufacturer)			16	(contact manufacturer)		
		1/2	16	(contact manufacturer)			16	(contact manufacturer)		
Particleboard Panel Siding (M-S Exterior Glue)		5/8	16	(contact manufacturer)			16	(contact manufacturer)		
		3/4	24	(contact manufacturer)			24	(contact manufacturer)		
Hardboard Siding (Direct to Studs)	Lap Siding	7/16	16	460	260	-	-	-	-	-
	Shiplap Edge Panel Siding	7/16	24	460	260	115	24	460	260	115
	Square Edge Panel Siding	7/16	24	460	260	115	24	460	260	115
Cellulosic Fiberboard Sheathing	Regular	1/2	16	90	50	-	16	90	50	-
	Structural	1/2	16	135	75	-	16	135	75	-
	Structural	25/32	16	165	90	-	16	165	90	-

- Nominal capacities shall be adjusted in accordance with Section 3.2.1 to determine ASD uniform load capacity and LRFD uniform resistances.
- Sheathing shall be plywood with 4 or more plies or OSB.
- Wood structural panels shall conform to the requirements for its type in DOC PS 1 or PS 2. Particleboard sheathing shall conform to ANSI A208.1. Hardboard panel and siding shall conform to the requirements of ANSI/CPA A135.6. Cellulosic fiberboard sheathing shall conform to ASTM C 208.
- Tabulated values are for maximum bending loads from wind. Loads are limited by bending or shear stress assuming a 2-span continuous condition. Where panels are continuous over 3 or more spans the tabulated values shall be permitted to be increased in accordance with the *ASD/LRFD Manual for Engineered Wood Construction*.
- Strength axis is defined as the axis parallel to the face and back orientation of the flakes or the grain (veneer), which is generally the long panel direction, unless otherwise marked.

3.2.2 Floor Sheathing

Floor sheathing shall be capable of resisting and transferring gravity loads to the floor framing. Sheathing used in diaphragm assemblies to resist lateral forces shall be designed in accordance with 4.2.

3.2.3 Roof Sheathing

Roof sheathing and its fasteners shall be capable of resisting and transferring wind and gravity loads to the roof framing. Maximum spans and nominal uniform

load capacities for roof sheathing materials are given in Table 3.2.2. The ASD allowable uniform load capacities to be used for wind design shall be determined by dividing the nominal uniform load capacities in Table 3.2.2 by an ASD reduction factor of 1.6. The LRFD factored uniform load capacities to be used for wind design shall be determined by multiplying the nominal uniform load capacities in Table 3.2.2 by a resistance factor, ϕ_b , of 0.85. Sheathing used in diaphragm assemblies to resist lateral forces shall be designed in accordance with 4.2.

Table 3.2.2 Nominal Uniform Load Capacities (psf) for Roof Sheathing Resisting Out-of-Plane Wind Loads^{1,3}

Sheathing Type ²	Span Rating or Grade	Minimum Thickness (in.)	Strength Axis ⁴ Applied Perpendicular to Supports					
			Rafter/Truss Spacing (in.)					
			12	16	19.2	24	32	48
			Nominal Uniform Loads (psf)					
Wood Structural Panels (Sheathing Grades, C-C, C-D, C-C Plugged, OSB)	24/0	3/8	425	240	165	105	-	-
	24/16	7/16	540	305	210	135	-	-
	32/16	15/32	625	355	245	155	90	-
	40/20	19/32	955	595	415	265	150	-
	48/24	23/32	1160	805	560	360	200	90
Wood Structural Panels (Single Floor Grades, Underlayment, C-C Plugged)	16 o.c.	19/32	705	395	275	175	100	-
	20 o.c.	19/32	815	455	320	205	115	-
	24 o.c.	23/32	1085	610	425	270	150	-
	32 o.c.	7/8	1395	830	575	370	205	90
	48 o.c.	1-1/8	1790	1295	1060	680	380	170

1. Nominal capacities shall be adjusted in accordance with Section 3.2.3 to determine ASD uniform load capacity and LRFD uniform resistances.
2. Wood structural panels shall conform to the requirements for its type in DOC PS 1 or PS 2.
3. Tabulated values are for maximum bending loads from wind. Loads are limited by bending or shear stress assuming a 2-span continuous condition. Where panels are continuous over 3 or more spans, the tabulated values shall be permitted to be increased in accordance with the *ASD/LRFD Manual for Engineered Wood Construction*.
4. Strength axis is defined as the axis parallel to the face and back orientation of the flakes or the grain (veneer), which is generally the long panel direction, unless otherwise marked.

3.3 Connections

Connections resisting induced wind and seismic forces shall be designed in accordance with the methods referenced in 2.1.2.1 for allowable stress design (ASD) and 2.1.2.2 for strength design (LRFD).

LATERAL FORCE- RESISTING SYSTEMS

4.1	General	12
4.2	Wood-Frame Diaphragms	13
4.3	Wood-Frame Shear Walls	22
4.4	Wood Structural Panels Designed to Resist Combined Shear and Uplift from Wind	35
Table 4.2.4	Maximum Diaphragm Aspect Ratios.....	14
Tables 4.2A-D	Nominal Unit Shear Capacities for Wood-Frame Diaphragms	18 – 21
Table 4.3.3.2	Unblocked Shear Wall Adjustment Factor, C_{ub}	23
Table 4.3.3.5	Shear Capacity Adjustment Factor, C_o	24
Table 4.3.4	Maximum Shear Wall Aspect Ratios.....	25
Tables 4.3A-D	Nominal Unit Shear Capacities for Wood-Frame Shear Walls	31 – 34
Table 4.4.1	Nominal Uplift Capacity of 7/16" Wood Structural Panel Sheathing or Siding– Combined Shear and Uplift	39
Table 4.4.2	Nominal Uplift Capacity of 3/8" Wood Structural Panel Sheathing or Siding– Uplift Only	39

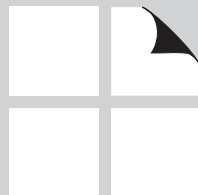

4.1 General

4.1.1 Design Requirements

The proportioning, design, and detailing of engineered wood systems, members, and connections in lateral force-resisting systems shall be in accordance with the reference documents in 2.1.2 and provisions in this chapter. A continuous load path, or paths, with adequate strength and stiffness shall be provided to transfer all forces from the point of application to the final point of resistance.

4.1.2 Shear Capacity

Nominal shear capacities of diaphragms and shear walls are provided for reference assemblies in Tables 4.2A, 4.2B, 4.2C, and 4.2D and Tables 4.3A, 4.3B, 4.3C, and 4.3D, respectively. Alternatively, shear capacity of diaphragms and shear walls shall be permitted to be calculated by principles of mechanics using values of fastener strength and sheathing shear capacity.

4.1.3 Deformation Requirements

Deformation of connections within and between structural elements shall be considered in design such that the deformation of each element and connection comprising the lateral force-resisting system is compatible with the deformations of the other lateral force-resisting elements and connections and with the overall system.

4.1.4 Boundary Elements

Shear wall and diaphragm boundary elements shall be provided to transfer the design tension and compression forces. Diaphragm and shear wall sheathing shall not be used to splice boundary elements. Diaphragm chords and collectors shall be placed in, or in contact with, the plane of the diaphragm framing unless it can be demonstrated that the moments, shears, and deflections, considering eccentricities resulting from other configurations, can be tolerated without exceeding the framing capacity and drift limits.

4.1.5 Wood Members and Systems Resisting Seismic Forces Contributed by Masonry and Concrete Walls

Wood-frame shear walls, wood-frame diaphragms, trusses, and other wood members and systems shall not be used to resist seismic forces contributed by masonry or concrete walls in structures over one story in height.

Exceptions:

1. Wood floor and roof members shall be permitted to be used in diaphragms and horizontal trusses to resist horizontal seismic forces contributed by masonry or concrete walls provided such forces do not result in torsional force distribution through the diaphragm or truss.
2. Vertical wood structural panel sheathed shear walls shall be permitted to be used to provide resistance to seismic forces contributed by masonry or concrete walls in two-story structures, provided the following requirements are met:
 - a. Story-to-story wall heights shall not exceed 12'.
 - b. Diaphragms shall not be considered to transmit lateral forces by torsional force distribution or cantilever past the outermost supporting shear wall.
 - c. Combined deflections of diaphragms and shear walls shall not permit design story drift of supported masonry or concrete walls to exceed the allowable story drift in accordance with Section 12.12.1 of *ASCE 7*.
 - d. Wood structural panel diaphragms shall be blocked diaphragms.
 - e. Wood structural panel shear walls shall be blocked shear walls and, for the lower story, the sheathing shall have a minimum thickness of 15/32".
 - f. There shall be no out-of-plane horizontal offsets between the first and second stories of wood structural panel shear walls.

4.1.6 Wood Members and Systems Resisting Seismic Forces from Other Concrete or Masonry Construction

Wood members and systems shall be designed to resist seismic forces from other concrete, or masonry components, including but not limited to: chimneys, fireplaces, concrete or masonry veneers, and concrete floors.

4.1.7 Toe-Nailed Connections

In seismic design categories D, E, and F, the capacity of toe-nailed connections shall not be used when calculating lateral load resistance to transfer seismic lateral forces greater than 150 pounds per lineal foot for ASD and 205 pounds per lineal foot for LRFD from diaphragms to shear walls, collectors, or other elements, or from shear walls to other elements.

4.2 Wood-Frame Diaphragms

4.2.1 Application Requirements

Wood-frame diaphragms shall be permitted to be used to resist lateral forces provided the deflection in the plane of the diaphragm, as determined by calculations, tests, or analogies drawn therefrom, does not exceed the maximum permissible deflection limit of attached load distributing or resisting elements. Permissible deflection shall be that deflection that will permit the diaphragm and any attached elements to maintain their structural integrity and continue to support their prescribed loads as determined by the applicable building code or standard. Framing members, blocking, and connections shall extend into the diaphragm a sufficient distance to develop the force transferred into the diaphragm.

4.2.2 Deflection

Calculations of diaphragm deflection shall account for bending and shear deflections, fastener deformation, chord splice slip, and other contributing sources of deflection.

The diaphragm deflection, δ_{dia} , shall be permitted to be calculated by use of the following equation:

$$\delta_{dia} = \frac{5vL^3}{8EAW} + \frac{0.25vL}{1000G_a} + \frac{\sum(x\Delta_c)}{2W} \quad (4.2-1)$$

where:

E = modulus of elasticity of diaphragm chords, psi

A = area of chord cross-section, in.²

G_a = apparent diaphragm shear stiffness from nail slip and panel shear deformation, kips/in. (from Column A, Tables 4.2A, 4.2B, 4.2C, or 4.2D)

L = diaphragm length, ft

v = induced unit shear in diaphragm, lbs/ft

W = diaphragm width, ft

x = distance from chord splice to nearest support, ft

Δ_c = diaphragm chord splice slip, in., at the induced unit shear in diaphragm

δ_{dia} = maximum mid-span diaphragm deflection determined by elastic analysis, in.

Alternatively, for wood structural panel diaphragms, deflection shall be permitted to be calculated using a rational analysis where apparent shear stiffness accounts for panel shear deformation and non-linear nail slip in the sheathing-to-framing connection.

4.2.3 Unit Shear Capacities

Tabulated nominal unit shear capacities for seismic design are provided in Column A of Tables 4.2A, 4.2B, 4.2C, and 4.2D; and for wind design in Column B of Tables 4.2A, 4.2B, 4.2C, and 4.2D. The ASD allowable unit shear capacity shall be determined by dividing the tabulated nominal unit shear capacity, modified by applicable footnotes, by the ASD reduction factor of 2.0. The LRFD factored unit resistance shall be determined by multiplying the tabulated nominal unit shear capacity, modified by applicable footnotes, by a resistance

factor, ϕ_D , of 0.80. No further increases shall be permitted.

4.2.4 Diaphragm Aspect Ratios

Size and shape of diaphragms shall be limited to the aspect ratios in Table 4.2.4.

Table 4.2.4 Maximum Diaphragm Aspect Ratios
(Horizontal or Sloped Diaphragms)

Diaphragm Sheathing Type	Maximum L/W Ratio
Wood structural panel, unblocked	3:1
Wood structural panel, blocked	4:1
Single-layer straight lumber sheathing	2:1
Single-layer diagonal lumber sheathing	3:1
Double-layer diagonal lumber sheathing	4:1

4.2.5 Horizontal Distribution of Shear

Diaphragms shall be defined as rigid or flexible for the purposes of distributing shear loads and designing for torsional moments. When a diaphragm is defined as flexible, the diaphragm shear forces shall be distributed to the vertical resisting elements based on tributary area. When a diaphragm is defined as rigid, the diaphragm shear forces shall be distributed based on the relative lateral stiffnesses of the vertical-resisting elements of the story below.

4.2.5.1 Torsional Irregularity: Structures with rigid wood-frame diaphragms shall be considered as torsionally irregular when the maximum story drift, computed including accidental torsion, at one end of the structure is more than 1.2 times the average of the story drifts at the two ends of the structure. Where torsional irregularity exists, diaphragms shall meet the following requirements:

1. The diaphragm conforms to 4.2.7.1, 4.2.7.2, or 4.2.7.3.
2. The L/W ratio of the diaphragm is not greater than 1:1 for one-story structures or not greater than 0.67:1 for structures over one story in height.

Exception: Where calculations show that diaphragm deflections can be tolerated, the

length, L, shall be permitted to be increased to an L/W ratio not greater than 1.5:1 when sheathed in conformance with 4.2.7.1 or not greater than 1:1 when sheathed in conformance with 4.2.7.2 or 4.2.7.3.

4.2.5.1.1 Open Front Structures: Open front structures utilizing wood-frame rigid diaphragms to distribute shear forces through torsion shall be permitted provided:

1. The diaphragm length, L, (normal to the open side) does not exceed 25'.
2. The L/W ratio of the diaphragm (as shown in Figure 4A) is less than or equal to 1:1 for one-story structures or 0.67:1 for structures over one story in height.

Exception: Where calculations show that diaphragm deflections can be tolerated, the length, L, (normal to the open side) shall be permitted to be increased to an L/W ratio not greater than 1.5:1 when sheathed in conformance with 4.2.7.1 or 4.2.7.3, or not greater than 1:1 when sheathed in conformance with 4.2.7.2.

Figure 4A Open Front Structure

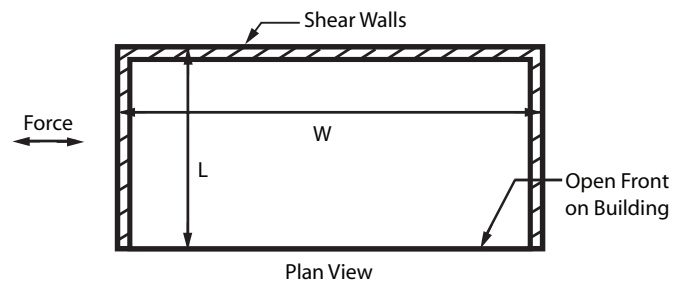

4.2.5.2 Cantilevered Diaphragms: Rigid wood-frame diaphragms shall be permitted to cantilever past the outermost supporting shear wall (or other vertical resisting element) a distance, L_c , of not more than 25' or 2/3 of the diaphragm width, W, whichever is smaller. Figure 4B illustrates the dimensions of L_c and W for a cantilevered diaphragm.

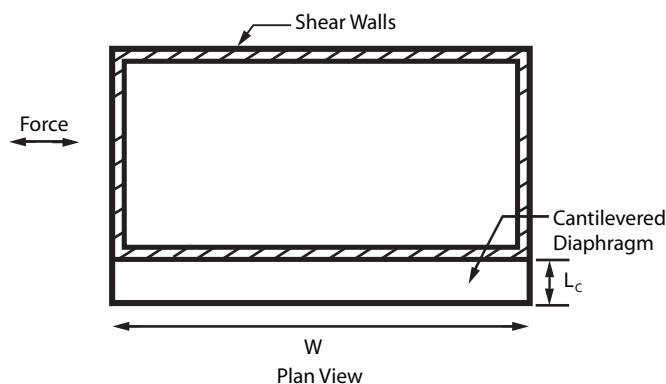
Figure 4B Cantilevered Building

4.2.6 Construction Requirements

4.2.6.1 Framing Requirements: Diaphragm boundary elements shall be provided to transmit the design tension, compression, and shear forces. Diaphragm sheathing shall not be used to splice boundary elements. Diaphragm chords and collectors shall be placed in, or in contact with, the plane of the diaphragm framing unless it can be demonstrated that the moments, shears, and deflections, considering eccentricities resulting from other configurations, can be tolerated without exceeding the framing capacity and drift limits.

4.2.6.2 Sheathing: Diaphragms shall be sheathed with approved materials. Details on sheathing types and thicknesses for commonly used floor, roof, and ceiling diaphragm assemblies are provided in 4.2.7 and Tables 4.2A, 4.2B, 4.2C, and 4.2D.

4.2.6.3 Fasteners: Sheathing shall be attached to framing members using nails or other approved fasteners alone, or in combination with adhesives. Nails shall be driven with the head of the nail flush with the surface of the sheathing. Other approved fasteners shall be driven as required for proper installation of that fastener.

4.2.7 Diaphragm Assemblies

4.2.7.1 Wood Structural Panel Diaphragms: Diaphragms sheathed with wood structural panel sheathing shall be permitted to be used to resist seismic and wind forces. Wood structural panel sheathing used for diaphragms that are part of the lateral force-resisting system shall be applied directly to the framing members and blocking.

Exception: Wood structural panel sheathing in a diaphragm is permitted to be fastened over solid lumber planking or laminated decking provided the following requirements are met:

1. Panel edges do not coincide with joints in the lumber planking or laminated decking.
2. Adjacent panel edges parallel to the planks or decking are fastened to a common member.
3. The planking or decking shall be of sufficient thickness to satisfy minimum fastener penetration in framing members and blocking as required in Table 4.2A.
4. Diaphragm aspect ratio (L/W) does not exceed that for a blocked wood structural panel diaphragm (4:1).
5. Diaphragm forces are transferred from wood structural panel sheathing to diaphragm boundary elements through planking or decking or by other methods.

4.2.7.1.1 Blocked Diaphragms: Where diaphragms are designated as blocked, all joints in sheathing shall occur over and be fastened to common framing members or common blocking. The size and spacing of fasteners at wood-frame diaphragm boundaries and panel edges shall be as prescribed in Table 4.2A. The diaphragm shall be constructed as follows:

1. Panels shall not be less than 4' x 8' except at boundaries and changes in framing where minimum panel dimension shall be 24" unless all edges of the undersized panels are supported by and fastened to framing members or blocking.
2. Nails shall be located at least 3/8" from the edges of panels. Maximum nail spacing at panel edges shall be 6" on center. Nails along intermediate framing members and blocking for panels shall be the same size as installed at the panel edges. Maximum nail spacing shall be 6" on center when support spacing of 48" on center is specified and 12" on center for closer support spacings.
3. The width of the nailed face of framing members and blocking shall be 2" nominal or greater at adjoining panel edges except that a 3" nominal or greater width at adjoining panel edges and staggered nailing at all panel edges are required where:
 - a. Nail spacing of 2-1/2" on center or less at adjoining panel edges is specified, or
 - b. 10d common nails having penetration in-

to framing members and blocking of more than 1-1/2" are specified at 3" on center or less at adjoining panel edges.

4. Wood structural panels shall conform to the requirements for their type in DOC PS1 or PS2.

4.2.7.1.2 High Load Blocked Diaphragms: All joints in sheathing shall occur over and be fastened to common framing members or common blocking. The size and spacing of fasteners at wood-frame diaphragm boundaries and panel edges shall be as prescribed in Table 4.2B and Figure 4C. The diaphragms shall be constructed as follows:

1. Panels shall not be less than 4' x 8' except at boundaries and changes in framing where minimum panel dimension shall be 24" unless all edges of the undersized panels are supported by and fastened to framing members or blocking.
2. Nails shall be located at least 3/8" from panel edges but not less than distances shown in Figure 4C. Maximum nail spacing at panel edges shall be 6" on center. Nails along intermediate framing members for panels shall be the same size as installed at the panel edges. Maximum nail spacing shall be 6" on center when support spacing of greater than 32" on center is specified. Maximum nail spacing shall be 12" on center for specified support spacing of 32" on center or less.
3. In diaphragm boundary members, lines of fasteners shall be equally spaced and fasteners within each line shall be staggered where spacing is 3" on center or less.
4. The width of the nailed face of framing members and blocking shall be 3" nominal or greater. The width of the nailed face not located at boundaries or adjoining panel edges shall be 2" nominal or greater.
5. Wood structural panels shall conform to the requirements for their type in DOC PS1 or PS2.

4.2.7.1.3 Unblocked Diaphragms: Where diaphragms are designated as unblocked, the diaphragms shall be constructed as specified in 4.2.7.1.1, except that blocking between supporting structural members at panel edges shall not be required. The size and spacing

of fasteners at wood-frame diaphragm boundaries and panel edges shall be as prescribed in Table 4.2C.

4.2.7.2 Diaphragms Diagonally Sheathed with Single-Layer of Lumber: Single diagonally sheathed lumber diaphragms shall be permitted to be used to resist seismic and wind forces. Single diagonally sheathed lumber diaphragms shall be constructed of minimum 1" thick nominal sheathing boards or 2" thick nominal lumber laid at an angle of approximately 45° to the supports. End joints in adjacent boards shall be separated by at least one joist space and there shall be at least two boards between joints on the same support. Nailing of diagonally sheathed lumber diaphragms shall be in accordance with Table 4.2D. Single diagonally sheathed lumber diaphragms shall be permitted to consist of 2" nominal lumber (1-1/2" thick) where the supports are not less than 3" nominal (2-1/2" thick) in width or 4" nominal (3-1/2" deep) in depth

4.2.7.3 Diaphragms Diagonally Sheathed with Double-Layer of Lumber: Double diagonally sheathed lumber diaphragms shall be permitted to be used to resist seismic and wind forces. Double diagonally sheathed lumber diaphragms shall be constructed of two layers of diagonal sheathing boards laid perpendicular to each other on the same face of the supporting members. Each chord shall be considered as a beam with uniform load per foot equal to 50% of the unit shear due to diaphragm action. The load shall be assumed as acting normal to the chord in the plane of the diaphragm in either direction. Nailing of diagonally sheathed lumber diaphragms shall be in accordance with Table 4.2D

4.2.7.4 Diaphragms Horizontally Sheathed with Single-Layer of Lumber: Horizontally sheathed lumber diaphragms shall be permitted to be used to resist seismic and wind forces. Horizontally sheathed lumber diaphragms shall be constructed of minimum 1" thick nominal sheathing boards or minimum 2" thick nominal lumber laid perpendicular to the supports. End joints in adjacent boards shall be separated by at least one joist space and there shall be at least two boards between joints on the same support. Nailing of horizontally sheathed lumber diaphragms shall be in accordance with Table 4.2D.

Figure 4C High Load Diaphragm

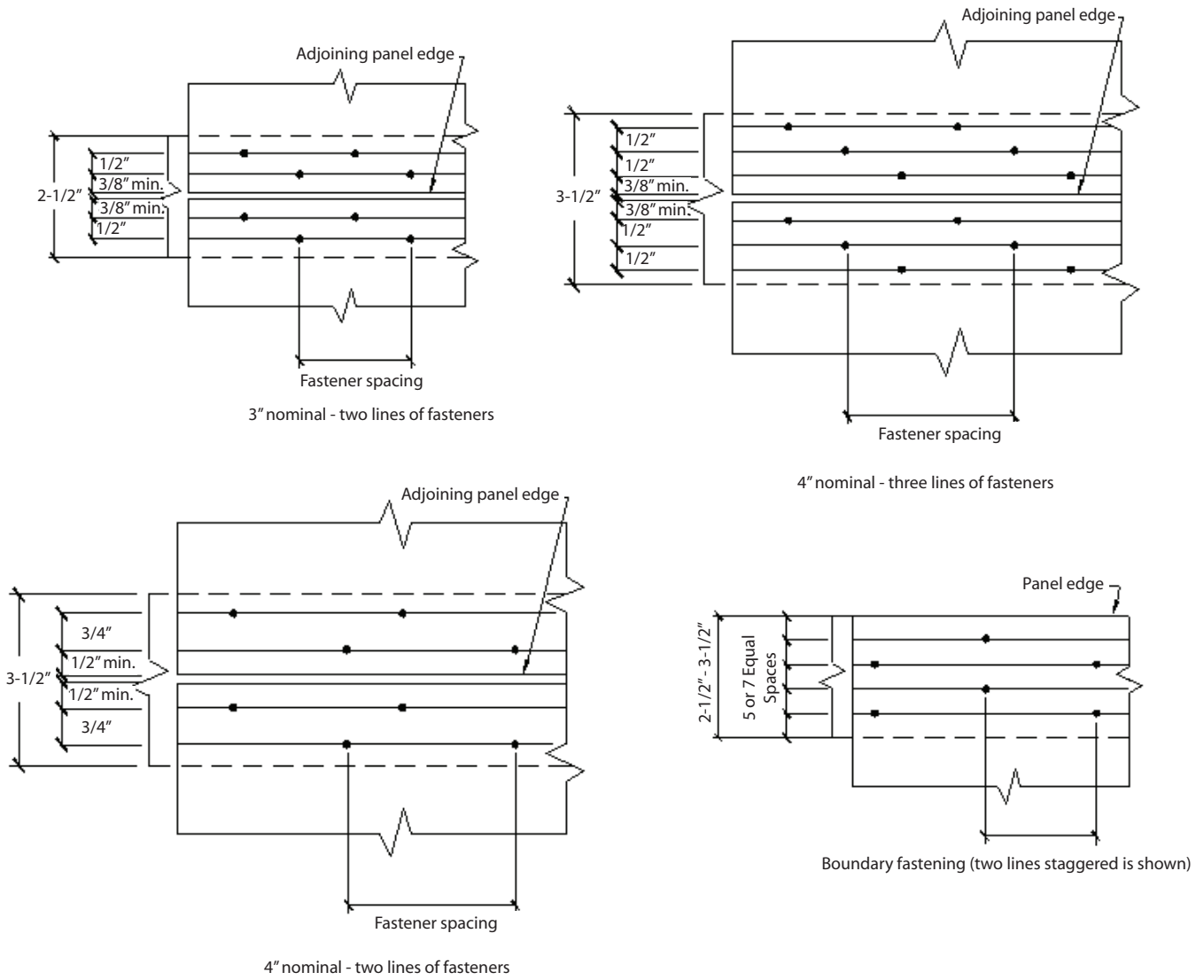

Note: Space adjoining panel edge joists 1/8". Minimum spacing between lines of fasteners is 3/8".

Table 4.2A Nominal Unit Shear Capacities for Wood-Frame Diaphragms

Sheathing Grade	Common Nail Size	Minimum Fastener Penetration in Framing Member or Blocking (in.)	Minimum Nominal Panel Thickness (in.)	Minimum Nominal Width of Nailed Face at Adjoining Panel Edges and Boundaries (in.)	A SEISMIC						B WIND							
					Nail Spacing (in.) at diaphragm boundaries (all cases), at continuous panel edges parallel to load (Cases 3 & 4), and at all panel edges (Cases 5 & 6)						Nail Spacing (in.) at other panel edges (Cases 1, 2, 3, & 4)							
					6	4	2-1/2	2	6	4	2-1/2	2	6	4	2-1/2	2		
Structural I	6d	1-1/4	5/16	2	V_s (plf)	G_a (kips/in.)	V_s (plf)	G_a (kips/in.)	V_s (plf)	G_a (kips/in.)	V_s (plf)	G_a (kips/in.)	V_w (plf)	V_w (plf)				
					OSB	PLY	OSB	PLY	OSB	PLY	OSB	PLY						
					370	15	12	500	8.5	7.5	750	10	10	840	20	15	520	700
	8d	1-3/8	3/8	3	420	12	9.5	560	7.0	6.0	840	9.5	8.5	950	17	13	590	785
					540	14	11	720	9.0	7.5	1060	13	10	1200	21	15	755	1010
					600	12	10	800	7.5	6.5	1200	10	9.0	1350	18	13	840	1120
10d	1-1/2	15/32	3	720	20	15	960	12	9.5	1440	16	13	1640	26	18	895	1190	
				340	15	10	450	9.0	7.0	670	13	9.5	760	21	13	475	630	
				380	12	9.0	500	7.0	6.0	760	10	8.0	860	17	12	530	700	
Sheathing and Single-Floor	6d	1-1/4	5/16	2	370	13	9.5	500	7.0	6.0	750	10	8.0	840	18	12	520	700
					420	10	8.0	560	5.5	5.0	840	8.5	7.0	950	14	10	590	785
					480	15	11	640	9.5	7.5	960	13	9.5	1090	21	13	670	895
	8d	1-3/8	3/8	3	540	12	9.5	720	7.5	6.0	1080	11	8.5	1220	18	12	755	1010
					510	14	10	680	8.5	7.0	1010	12	9.5	1150	20	13	715	950
					570	11	9.0	760	7.0	6.0	1140	10	8.0	1290	17	12	800	1065
10d	1-1/2	15/32	3	540	13	9.5	720	7.5	6.5	1060	11	8.5	1200	19	13	755	1010	
				600	10	8.5	800	6.0	5.5	1200	9.0	7.5	1350	15	11	840	1120	
				650	21	14	860	12	9.5	1300	17	12	1470	28	16	910	1205	
10d	1-1/2	19/32	3	640	21	14	850	13	9.5	1280	18	12	1460	28	17	895	1190	
				720	17	12	960	10	8.0	1440	14	11	1640	24	15	1010	1345	

- Nominal unit shear capacities shall be adjusted in accordance with 4.2.3 to determine ASD allowable unit shear capacity and LRFD factored unit resistance. For general construction requirements see 4.2.6. For specific requirements, see 4.2.7.1 for wood structural panel diaphragms. See Appendix A for common nail dimensions.
- For species and grades of framing other than Douglas-Fir-Larch or Southern Pine, reduced nominal unit shear capacities shall be determined by multiplying the tabulated nominal unit shear capacity by the Specific Gravity Adjustment Factor = $[1 - (0.5 - G)]$, where G = Specific Gravity of the framing lumber from the *NDS* (Table 11.3.2A). The Specific Gravity Adjustment Factor shall not be greater than 1.
- Apparent shear stiffness values, G_a , are based on nail slip in framing with moisture content less than or equal to 19% at time of fabrication and panel stiffness values for diaphragms constructed with either OSB or 3-ply plywood panels. When 4-ply or 5-ply plywood panels or composite panels are used, G_a values shall be permitted to be increased by 1.2.
- Where moisture content of the framing is greater than 19% at time of fabrication, G_a values shall be multiplied by 0.5.

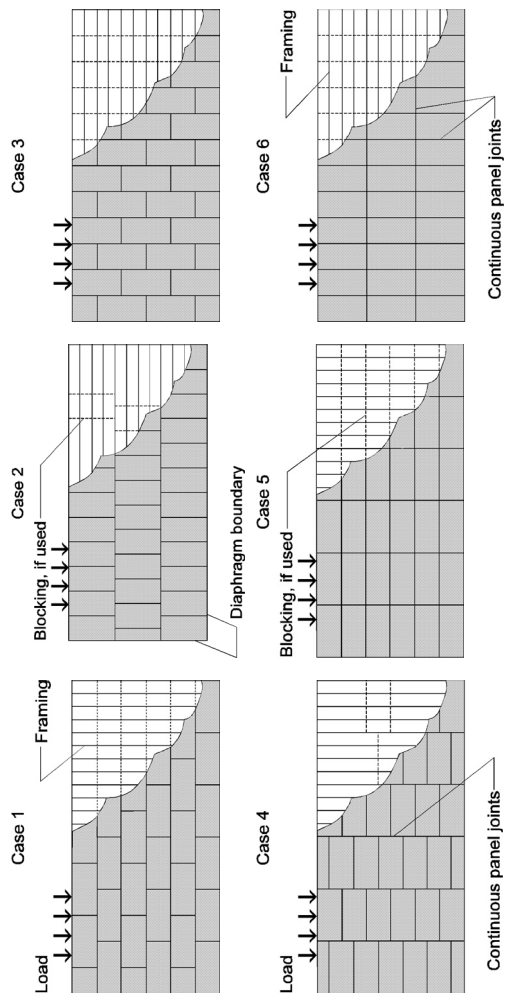
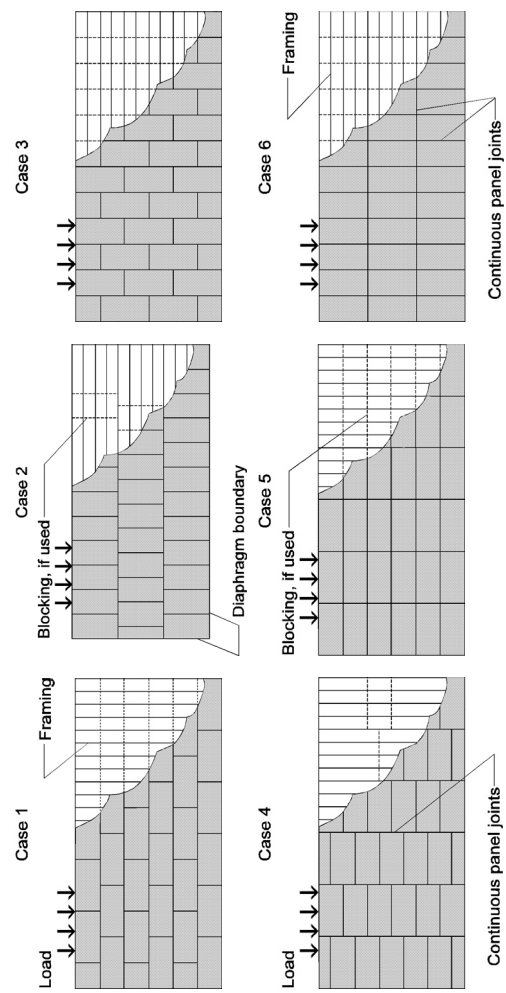

Table 4.2B Nominal Unit Shear Capacities for Wood-Frame Diaphragms

Blocked Wood Structural Panel Diaphragms Utilizing Multiple Rows of Fasteners (High Load Diaphragms)^{1,2,3,4}

Sheathing Grade	A SEISMIC										B WIND								
	4				2-1/2				2-1/2				2-1/2						
	Nail Spacing (in.) at diaphragm boundaries (all cases), at continuous panel edges parallel to load (Cases 3 & 4), and at all panel edges (Cases 5 & 6)		Nail Spacing (in.) at other panel edges (Cases 1, 2, 3, & 4)		Nail Spacing (in.) at diaphragm boundaries (all cases), at continuous panel edges parallel to load (Cases 3 & 4), and at all panel edges (Cases 5 & 6)		Nail Spacing (in.) at other panel edges (Cases 1, 2, 3, & 4)		Nail Spacing (in.) at diaphragm boundaries (all cases), at continuous panel edges parallel to load (Cases 3 & 4), and at all panel edges (Cases 5 & 6)		Nail Spacing (in.) at other panel edges (Cases 1, 2, 3, & 4)		Nail Spacing (in.) at diaphragm boundaries (all cases), at continuous panel edges parallel to load (Cases 3 & 4), and at all panel edges (Cases 5 & 6)		Nail Spacing (in.) at other panel edges (Cases 1, 2, 3, & 4)				
Common Nail Size	Minimum Fastener Penetration in Framing Member or Blocking (in.)	Minimum Nominal Panel Thickness (in.)	Minimum Width of Nailed Face at Adjoining Edges and Boundaries (in.)	Lines of Fasteners	OSB		PLY		OSB		PLY		OSB		PLY				
					V_s (plf)	G_a (kips/in.)	V_s (plf)	G_a (kips/in.)	V_s (plf)	G_a (kips/in.)	V_s (plf)	G_a (kips/in.)	V_s (plf)	G_a (kips/in.)	V_s (plf)	G_a (kips/in.)	V_w (plf)	V_w (plf)	
Structural I	10d	15/32	3	2	1210	24	1630	53	28	1750	50	27	2300	56	29	1695	2280	2450	3220
					1400	33	1830	48	27	2010	44	25	2580	51	28	1960	2560	2815	3610
					1750	50	2440	61	30	2570	59	30	2790	70	32	2450	3415	3600	3905
					1340	36	1760	52	29	1930	47	27	2510	54	29	1875	2465	2700	3515
					1560	29	1980	46	27	2220	40	25	2880	48	27	2185	2770	3110	4030
					1930	47	2640	60	31	2810	57	30	3580	64	32	2700	3695	3935	5010
					1460	33	1910	50	29	2100	45	27	2730	53	30	2045	2675	2940	3820
					1710	26	2140	43	27	2420	37	24	3130	45	27	2395	2995	3390	4380
					2100	45	2720	59	32	3050	56	31	3600	68	34	2940	4005	4270	5040
					1050	43	1450	55	23	1530	53	23	2020	58	24	1470	2030	2140	2830
1210	36	1630	50	22	1750	46	21	2210	55	23	1695	2280	2450	3095					
1530	53	2170	62	24	2260	61	24	2390	72	26	2140	3040	3165	3345					
1300	34	1720	49	23	1870	45	22	2450	52	23	1820	2410	2620	3430					
1510	27	1930	43	21	2160	37	20	2740	46	22	2115	2700	3025	3835					
1870	45	2580	57	24	2730	55	24	2970	68	26	2620	3610	3820	4160					
1420	30	1870	46	23	2040	42	22	2670	50	24	1990	2620	2855	3740					
1650	24	2100	40	21	2350	34	20	2890	45	23	2310	2940	3290	4045					
2040	42	2800	56	25	2960	53	25	3130	71	28	2855	3920	4145	4380					



- Nominal unit shear capacities shall be adjusted in accordance with 4.2.3 to determine ASD allowable unit shear capacity and LRFD factored unit resistance. For general construction requirements see 4.2.6. For specific requirements, see 4.2.7.1 for wood structural panel diaphragms. See Appendix A for common nail dimensions.
- For species and grades of framing other than Douglas-Fir-Larch or Southern Pine, reduced nominal unit shear capacities shall be determined by multiplying the tabulated nominal unit shear capacity by the Specific Gravity Adjustment Factor = $[1 - (0.5 - G)]$, where G = Specific Gravity of the framing lumber from the NDS (Table 11.3.2A). The Specific Gravity Adjustment Factor shall not be greater than 1.
- Apparent shear stiffness values, G_s , are based on nail slip in framing with moisture content less than or equal to 19% at time of fabrication and panel stiffness values for diaphragms constructed with either OSB or 3-ply plywood panels. When 4-ply or 5-ply plywood panels or composite panels are used, G_s values shall be permitted to be increased by 1.2.
- Where moisture content of the framing is greater than 19% at time of fabrication, G_s values shall be multiplied by 0.5.

Table 4.2C Nominal Unit Shear Capacities for Wood-Frame Diaphragms**Unblocked Wood Structural Panel Diaphragms^{1,2,3,4}**

Sheathing Grade	Common Nail Size	Minimum Fastener Penetration in Framing (in.)	Minimum Nominal Panel Thickness (in.)	Minimum Nominal Width of Nailed Face at Supported Edges and Boundaries (in.)	A SEISMIC				B WIND			
					6 in. Nail Spacing at diaphragm boundaries and supporting members				Case 1	Cases 2,3,4,5,6	Case 1	Cases 2,3,4,5,6
					V _s (plf)	G _a (kips/in.)	V _s (plf)	G _a (kips/in.)				
Structural I	6d	1-1/4	5/16	2	OSB	PLY	OSB	PLY	460	350		
				3	9.0	7.0	6.0	6.0	4.5	520	390	
	8d	1-3/8	3/8	2	8.5	7.0	360	6.0	4.5	670	505	
				3	7.5	6.0	400	5.0	4.0	740	560	
	10d	1-1/2	15/32	2	14	10	430	9.5	7.0	800	600	
				3	12	9.0	480	8.0	6.0	895	670	
Sheathing and Single-Floor	6d	1-1/4	5/16	2	9.0	6.5	220	6.0	4.0	420	310	
				3	7.0	5.5	250	5.0	3.5	475	350	
			3/8	2	330	7.5	5.5	250	5.0	4.0	460	350
				3	370	6.0	4.5	280	4.0	3.0	520	390
	8d	1-3/8	3/8	2	430	9.0	6.5	320	6.0	4.5	600	450
				3	480	7.5	5.5	360	5.0	3.5	670	505
			7/16	2	460	8.5	6.0	340	5.5	4.0	645	475
				3	510	7.0	5.5	380	4.5	3.5	715	530
	10d	1-1/2	15/32	2	480	7.5	5.5	360	5.0	4.0	670	505
				3	530	6.5	5.0	400	4.0	3.5	740	560
			15/32	2	510	15	9.0	380	10	6.0	715	530
				3	580	12	8.0	430	8.0	5.5	810	600
19/32	1-1/2	2	570	13	8.5	430	8.5	5.5	800	600		
		3	640	10	7.5	480	7.0	5.0	895	670		

- Nominal unit shear capacities shall be adjusted in accordance with 4.2.3 to determine ASD allowable unit shear capacity and LRFD factored unit resistance. For general construction requirements see 4.2.6. For specific requirements, see 4.2.7.1 for wood structural panel diaphragms. See Appendix A for common nail dimensions.
- For species and grades of framing other than Douglas-Fir-Larch or Southern Pine, reduced nominal unit shear capacities shall be determined by multiplying the tabulated nominal unit shear capacity by the Specific Gravity Adjustment Factor = $[1 - (0.5 - G)]$, where G = Specific Gravity of the framing lumber from the *NDS* (Table 11.3.2A). The Specific Gravity Adjustment Factor shall not be greater than 1.
- Apparent shear stiffness values G_a are based on nail slip in framing with moisture content less than or equal to 19% at time of fabrication and panel stiffness values for diaphragms constructed with either OSB or 3-ply plywood panels. When 4-ply or 5-ply plywood panels or composite panels are used, G_a values shall be permitted to be increased by 1.2.
- Where moisture content of the framing is greater than 19% at time of fabrication, G_a values shall be multiplied by 0.5.

Table 4.2D Nominal Unit Shear Capacities for Wood-Frame Diaphragms

Lumber Diaphragms¹

Sheathing Material	Sheathing Nominal Dimensions	Type, Size, and Number of Nails per Board		SEISMIC	B	
		Nailing at Intermediate and End Bearing Supports (Nails/board/support)	Nailing at Boundary Members (Nails/board/end)			V _s (plf)
Horizontal Lumber Sheathing	1x6	2-8d common nails (3-8d box nails)	3-8d common nails (5-8d box nails)	100	1.5	140
	1x8	3-8d common nails (4-8d box nails)	4-8d common nails (6-8d box nails)			
	2x6	2-16d common nails (3-16d box nails)	3-16d common nails (5-16d box nails)			
Diagonal Lumber Sheathing	1x6	2-8d common nails (3-8d box nails)	3-8d common nails (5-8d box nails)	600	6.0	840
	1x8	3-8d common nails (4-8d box nails)	4-8d common nails (6-8d box nails)			
	2x6	2-16d common nails (3-16d box nails)	3-16d common nails (5-16d box nails)			
Double Diagonal Lumber Sheathing	1x6	2-8d common nails (3-8d box nails)	3-8d common nails (5-8d box nails)	1200	9.5	1680
	1x8	3-8d common nails (4-8d box nails)	4-8d common nails (6-8d box nails)			
	2x6	2-16d common nails (3-16d box nails)	3-16d common nails (5-16d box nails)			
Diagonal Lumber Sheathing	1x6	2-8d common nails (3-8d box nails)	3-8d common nails (5-8d box nails)	1200	9.5	1680
	1x8	3-8d common nails (4-8d box nails)	4-8d common nails (6-8d box nails)			
	2x6	2-16d common nails (3-16d box nails)	3-16d common nails (5-16d box nails)			

1. Nominal unit shear capacities shall be adjusted in accordance with 4.2.3 to determine ASD allowable unit shear capacity and LRFD factored unit resistance. For general construction requirements see 4.2.6. For specific requirements, see 4.2.7.2 for diaphragms diagonally sheathed with a single-layer of lumber, see 4.2.7.3 for diaphragms diagonally sheathed with a double-layer of lumber, and see 4.2.7.4 for diaphragms horizontally sheathed with a single-layer of lumber. See Appendix A for common and box nail dimensions.

4.3 Wood-Frame Shear Walls

4.3.1 Application Requirements

Wood-frame shear walls shall be permitted to resist lateral forces provided the deflection of the shear wall, as determined by calculations, tests, or analogies drawn therefrom, does not exceed the maximum permissible deflection limit. Permissible deflection shall be that deflection that permits the shear wall and any attached elements to maintain their structural integrity and continue to support their prescribed loads as determined by the applicable building code or standard. Framing members, blocking, and connections shall extend into the shear wall a sufficient distance to develop the force transferred into the shear wall.

4.3.2 Deflection

Calculations of shear wall deflection shall account for bending and shear deflections, fastener deformation, anchorage slip, and other contributing sources of deflection.

The shear wall deflection, δ_{sw} , shall be permitted to be calculated by use of the following equation:

$$\delta_{sw} = \frac{8vh^3}{EAb} + \frac{vh}{1000G_a} + \frac{h\Delta_a}{b} \quad (4.3-1)$$

where:

b = shear wall length, ft

Δ_a = total vertical elongation of wall anchorage system (including fastener slip, device elongation, rod elongation, etc.) at the induced unit shear in the shear wall, in.

E = modulus of elasticity of end posts, psi

A = area of end post cross-section, in.²

G_a = apparent shear wall shear stiffness from nail slip and panel shear deformation, kips/in. (from Column A, Tables 4.3A, 4.3B, 4.3C, or 4.3D)

h = shear wall height, ft

v = induced unit shear, lbs/ft

δ_{sw} = maximum shear wall deflection determined by elastic analysis, in.

Alternatively, for wood structural panel shear walls, deflection shall be permitted to be calculated using a rational analysis where apparent shear stiffness accounts for panel shear deformation and non-linear nail slip in the sheathing to framing connection.

4.3.2.1 Deflection of Perforated Shear Walls: The deflection of a perforated shear wall shall be calculated in accordance with 4.3.2, where v in equation 4.3-1 is equal to v_{max} obtained in equation 4.3-9 and b is taken as ΣL_j .

4.3.2.2 Deflection of Unblocked Wood Structural Panel Shear Walls: The deflection of an unblocked wood structural panel shear wall shall be permitted to be calculated in accordance with 4.3.2 using a G_a for 24" stud spacing and nails spaced at 6" on center at panel edges and 12" on center at intermediate framing members. The induced unit shear, v , in pounds per foot used in Equation 4.3-1 shall be divided by C_{ub} , from Table 4.3.3.2.

4.3.3 Unit Shear Capacities

The ASD allowable unit shear capacity shall be determined by dividing the tabulated nominal unit shear capacity, modified by applicable footnotes, by the ASD reduction factor of 2.0. The LRFD factored unit resistance shall be determined by multiplying the tabulated nominal unit shear capacity, modified by applicable footnotes, by a resistance factor, ϕ_D , of 0.80. No further increases shall be permitted.

4.3.3.1 Tabulated Nominal Unit Shear Capacities: Tabulated nominal unit shear capacities for seismic design are provided in Column A of Tables 4.3A, 4.3B, 4.3C, and 4.3D; and for wind design in Column B of Tables 4.3A, 4.3B, 4.3C, and 4.3D.

4.3.3.2 Unblocked Wood Structural Panel Shear Walls: Wood structural panel shear walls shall be permitted to be unblocked provided nails are installed into framing in accordance with Table 4.3.3.2 and the strength is calculated in accordance with Equation 4.3-2. Unblocked shear wall height shall not exceed 16

feet. Design coefficients and factors for blocked shear walls as specified in 4.3.3 shall be used.

The nominal unit shear capacity of an unblocked wood structural panel shear wall, v_{ub} , shall be calculated using the following equation:

$$v_{ub} = v_b C_{ub} \quad (4.3-2)$$

where:

C_{ub} = Unblocked shear wall adjustment factor from Table 4.3.3.2

v_b = Nominal unit shear capacity (lbs/ft) from Table 4.3A for wood structural panel blocked shear walls with 24" stud spacing and nails spaced at 6" on center at panel edges.

v_{ub} = Nominal unit shear capacity (lbs/ft) for unblocked shear wall.

Table 4.3.3.2 Unblocked Shear Wall Adjustment Factor, C_{ub}

Nail Spacing (in.)		Stud Spacing (in.)			
		12	16	20	24
Supported Edges	Intermediate Framing				
6	6	1.0	0.8	0.6	0.5
6	12	0.8	0.6	0.5	0.4

4.3.3.3 Summing Shear Capacities: For shear walls sheathed with the same construction and materials on opposite sides of the same wall, the combined nominal unit shear capacity, v_{sc} or v_{wc} , shall be permitted to be taken as twice the nominal unit shear capacity for an equivalent shear wall sheathed on one side.

4.3.3.3.1 For seismic design of shear walls sheathed with the same construction and materials on opposite sides of a shear wall, the shear wall deflection shall be calculated using the combined apparent shear wall shear stiffness, G_{ac} and the combined nominal unit shear capacity, v_{sc} , using the following equations:

$$G_{ac} = G_{a1} + G_{a2} \quad (4.3-3)$$

$$v_{sc} = K_{min} G_{ac} \quad (4.3-4)$$

where:

G_{ac} = combined apparent shear wall shear stiffness of two-sided shear wall, kips/in.

G_{a1} = apparent shear wall shear stiffness for side 1, kips/in. (from Column A, Tables 4.3A, 4.3B, 4.3C, or 4.3D)

G_{a2} = apparent shear wall shear stiffness for side 2, kips/in. (from Column A, Tables 4.3A, 4.3B, 4.3C, or 4.3D)

K_{min} = minimum ratio of v_{s1}/G_{a1} or v_{s2}/G_{a2}

v_{s1} = nominal unit shear capacity for side 1, lbs/ft (from Column A, Tables 4.3A, 4.3B, 4.3C, or 4.3D)

v_{s2} = nominal unit shear capacity for side 2, lbs/ft (from Column A, Tables 4.3A, 4.3B, 4.3C, or 4.3D)

v_{sc} = Combined nominal unit shear capacity of two-sided shear wall for seismic design, lbs/ft

4.3.3.3.2 Nominal unit shear capacities for shear walls sheathed with dissimilar materials on the same side of the wall are not cumulative. For shear walls sheathed with dissimilar materials on opposite sides, the combined nominal unit shear capacity, v_{sc} or v_{wc} , shall be either two times the smaller nominal unit shear capacity or the larger nominal unit shear capacity, whichever is greater.

Exception: For wind design, the combined nominal unit shear capacity, v_{wc} , of shear walls sheathed with a combination of wood structural panels, hardboard panel siding, or structural fiberboard on one side and gypsum wallboard on the opposite side shall equal the sum of the sheathing capacities of each side.

4.3.3.4 Summing Shear Wall Lines: The nominal shear capacity for shear walls in a line, utilizing shear walls sheathed with the same materials and construction, shall be permitted to be combined if the induced shear load is distributed so as to provide the same deflection, δ_{sw} , in each shear wall. Summing nominal unit shear capacities of dissimilar materials applied to the same wall line is not allowed.

4.3.3.5 Shear Capacity of Perforated Shear Walls: The nominal shear capacity of a perforated shear wall shall be taken as the tabulated nominal unit shear capacity multiplied by the sum of the shear wall segment lengths, ΣL_i , and the appropriate shear capacity adjustment factor, C_o , from Table 4.3.3.5 or calculated using the following equation:

$$C_o = \left(\frac{r}{3-2r} \right) \frac{L_{tot}}{\Sigma L_i} \quad (4.3-5)$$

$$r = \frac{1}{1 + \frac{A_o}{h \Sigma L_i}} \quad (4.3-6)$$

where:

r = sheathing area ratio

L_{tot} = total length of a perforated shear wall including the lengths of perforated shear wall segments and the lengths of segments containing openings

A_o = total area of openings in the perforated shear wall where individual opening areas are calculated as the opening width times the clear opening height. Where sheathing is not applied to framing above or be-

low the opening, these areas shall be included in the total area of openings.

Where the opening height is less than $h/3$, an opening height of $h/3$ shall be used

h = height of the perforated shear wall

ΣL_i = sum of perforated shear wall segment lengths, ft

4.3.4 Shear Wall Aspect Ratios

Size and shape of shear walls shall be limited to the aspect ratios in Table 4.3.4.

4.3.4.1 Aspect Ratio of Perforated Shear Wall Segments: The aspect ratio limitations of Table 4.3.4 shall apply to perforated shear wall segments within a perforated shear wall as illustrated in Figure 4D. Portions of walls with aspect ratios exceeding 3.5:1 shall not be considered in the sum of shear wall segments. In the design of perforated shear walls to resist seismic forces, the nominal shear capacity of the perforated shear wall shall be multiplied by $2b_s/h$ when the aspect ratio of the narrowest perforated shear wall segment included in the sum of shear wall segment lengths, ΣL_i , is greater than 2:1, but does not exceed 3.5:1.

Table 4.3.3.5 Shear Capacity Adjustment Factor, C_o

Wall Height, h	Maximum Opening Height ¹				
	h/3	h/2	2h/3	5h/6	h
8' Wall	2'-8"	4'-0"	5'-4"	6'-8"	8'-0"
10' Wall	3'-4"	5'-0"	6'-8"	8'-4"	10'-0"
Percent Full-Height Sheathing ²	Effective Shear Capacity Ratio				
10%	1.00	0.69	0.53	0.43	0.36
20%	1.00	0.71	0.56	0.45	0.38
30%	1.00	0.74	0.59	0.49	0.42
40%	1.00	0.77	0.63	0.53	0.45
50%	1.00	0.80	0.67	0.57	0.50
60%	1.00	0.83	0.71	0.63	0.56
70%	1.00	0.87	0.77	0.69	0.63
80%	1.00	0.91	0.83	0.77	0.71
90%	1.00	0.95	0.91	0.87	0.83
100%	1.00	1.00	1.00	1.00	1.00

¹ The maximum opening height shall be taken as the maximum opening clear height in a perforated shear wall. Where areas above and/or below an opening remain unsheathed, the height of each opening shall be defined as the clear height of the opening plus the unsheathed areas.

² The sum of the perforated shear wall segment lengths, ΣL_i , divided by the total length of the perforated shear wall.

Table 4.3.4 Maximum Shear Wall Aspect Ratios

Shear Wall Sheathing Type	Maximum h/b_s Ratio
Wood structural panels, unblocked	2:1
Wood structural panels, blocked	3.5:1 ¹
Particleboard, blocked	2:1
Diagonal sheathing, conventional	2:1
Gypsum wallboard	2:1 ²
Portland cement plaster	2:1 ²
Structural Fiberboard	3.5:1 ³

- 1 For design to resist seismic forces, the shear wall aspect ratio shall not exceed 2:1 unless the nominal unit shear capacity is multiplied by $2b_s/h$.
- 2 Walls having aspect ratios exceeding 1.5:1 shall be blocked shear walls.
- 3 For design to resist seismic forces, the shear wall aspect ratio shall not exceed 1:1 unless the nominal unit shear capacity is multiplied by the Aspect Ratio Factor (Seismic) = $0.1+0.9b_s/h$. The value of the Aspect Ratio Factor (Seismic) shall not be greater than 1.0. For design to resist wind forces, the shear wall aspect ratio shall not exceed 1:1 unless the nominal unit shear capacity is multiplied by the Aspect Ratio Factor (Wind) = $1.09-0.09h/b_s$. The value of the Aspect Ratio Factor (Wind) shall not be greater than 1.0.

4.3.4.2 Aspect Ratio of Force-transfer Shear Walls: The aspect ratio limitations of Table 4.3.4 shall apply to the overall shear wall including openings and to each wall pier at the sides of openings. The height of a wall pier with an opening on one side shall be defined as the clear height of the pier at the side of the opening. The height of a wall pier with an opening on each side shall be defined as the larger of the clear heights of the pier at the sides of the openings. The length of a wall pier shall be defined as the sheathed length of the pier. Wall piers with aspect ratios exceeding 3.5:1 shall not be considered as portions of force-transfer shear walls.

4.3.5 Shear Wall Types

Where individual full-height wall segments are designed as shear walls, the provisions of 4.3.5.1 shall apply. For shear walls with openings, where framing members, blocking, and connections around the openings are designed for force transfer around the openings (force-transfer shear walls) the provisions of 4.3.5.2 shall apply. For shear walls with openings, where framing members, blocking, and connections around the opening are not designed for force transfer around the openings (perforated shear walls) the provisions of 4.3.5.3 shall apply or individual full-height wall segments shall be designed per 4.3.5.1

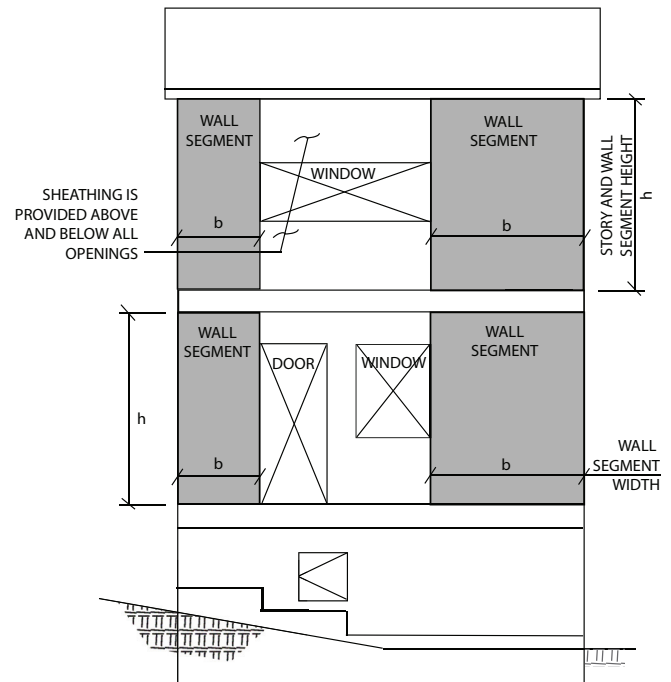
Figure 4D Typical Shear Wall Height-to-Width Ratio for Perforated Shear Walls

Note: b_s is the minimum shear wall segment length, b , in the perforated shear wall.

4.3.5.1 Individual Full-Height Wall Segments: Where individual full-height wall segments are designed as shear walls without openings, the aspect ratio limitations of 4.3.4 shall apply to each full-height wall segment as illustrated in Figure 4E. The following limitations shall apply:

1. Openings shall be permitted to occur beyond the ends of a shear wall. The length of such openings shall not be included in the length of the shear wall.
2. Where out-of-plane offsets occur, portions of the wall on each side of the offset shall be considered as separate shear wall lines.
3. Collectors for shear transfer shall be provided through the full length of the shear wall line.

Figure 4E Typical Individual Full-Height Wall Segments Height-to-Width Ratio

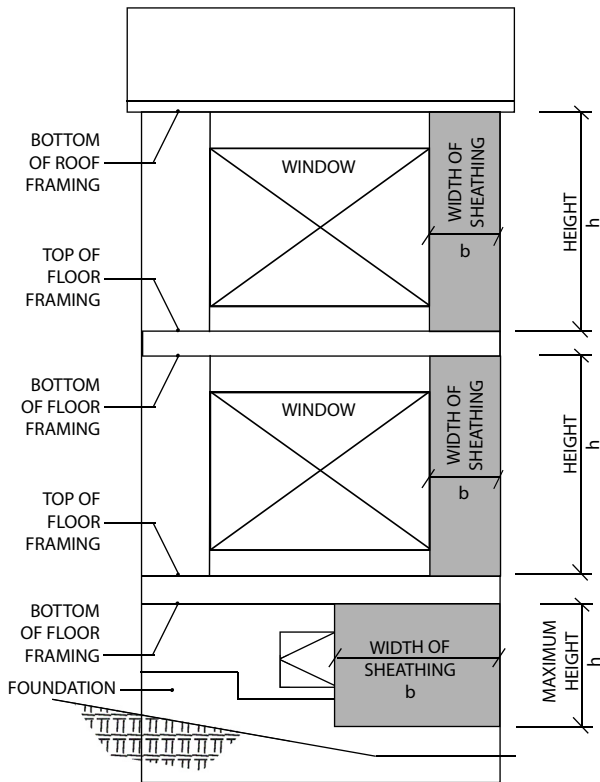

4.3.5.2 Force-transfer Shear Walls: Where shear walls with openings are designed for force transfer around the openings, the aspect ratio limitations of 4.3.4.2 shall apply as illustrated in Figure 4F. Design for force transfer shall be based on a rational analysis. The following limitations shall apply:

1. The length of each wall pier shall not be less than 2'.
2. A full-height wall segment shall be located at each end of a force-transfer shear wall.
3. Where out-of-plane offsets occur, portions of the wall on each side of the offset shall be considered as separate force-transfer shear walls.
4. Collectors for shear transfer shall be provided through the full length of the force-transfer shear wall.

Figure 4F Typical Shear Wall Height-to-Width Ratio for Shear Walls Designed for Force Transfer Around Openings

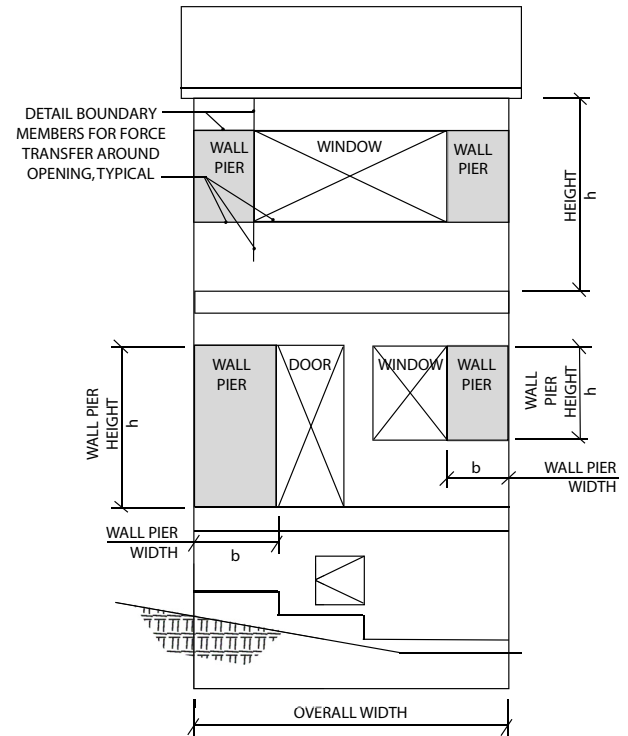

4.3.5.3 Perforated Shear Walls: Where wood structural panel shear walls with openings are not designed for force transfer around the openings, they shall be designed as perforated shear walls. The following limitations shall apply:

1. A perforated shear wall segment shall be located at each end of a perforated shear wall. Openings shall be permitted to occur beyond the ends of the perforated shear wall, provided the lengths of such openings are not included in the length of the perforated shear wall.
2. The aspect ratio limitations of Section 4.3.4.1 shall apply.
3. The nominal unit shear capacity for a single-sided wall shall not exceed 1,740 plf for seismic or 2,435 plf for wind as given in Table 4.3A. The nominal unit shear capacity for a double-sided wall shall not exceed 2,435 plf for wind.
4. Where out-of-plane offsets occur, portions of the wall on each side of the offset shall be considered as separate perforated shear walls.

5. Collectors for shear transfer shall be provided through the full length of the perforated shear wall.
6. A perforated shear wall shall have uniform top-of-wall and bottom-of-wall elevations. Perforated shear walls not having uniform elevations shall be designed by other methods.
7. Perforated shear wall height, h , shall not exceed 20'

4.3.6 Construction Requirements

4.3.6.1 Framing Requirements: All framing members and blocking used for shear wall construction shall be 2" nominal or greater. Where shear walls are designed as blocked, all joints in sheathing shall occur over and be fastened to common framing members or common blocking. Shear wall boundary elements, such as end posts, shall be provided to transmit the design tension and compression forces. Shear wall sheathing shall not be used to splice boundary elements. End posts (studs or columns) shall be framed to provide full end bearing.

4.3.6.1.1 Tension and Compression Chords: Tension force, T , and a compression force, C , resulting from shear wall overturning forces at each story level shall be calculated in accordance with the following:

$$T = C = \nu h \quad (4.3-7)$$

where:

C = compression force, lbs

h = shear wall height, ft

T = tension force, lbs

ν = induced unit shear, lbs/ft

4.3.6.1.2 Tension and Compression Chords of Perforated Shear Walls: Each end of each perforated shear wall shall be designed for a tension force, T , and a compression force, C . Each end of each perforated shear wall segment shall be designed for a compression force, C , in each segment. For perforated shear walls, the values for T and C resulting from shear wall overturning at each story level shall be calculated in accordance with the following:

$$T = C = \frac{Vh}{C_o \sum L_i} \quad (4.3-8)$$

where:

C_o = shear capacity adjustment factor from Table 4.3.3.5

V = induced shear force in perforated shear wall, lbs

$\sum L_i$ = sum of perforated shear wall segment lengths, ft

4.3.6.2 Sheathing: Shear walls shall be sheathed with approved materials attached directly to the framing members, and blocking where required, except as permitted in 4.3.7.2. Details on sheathing types and thicknesses for commonly used shear wall assemblies are provided in 4.3.7 and Tables 4.3A, 4.3B, 4.3C, and 4.3D.

4.3.6.3 Fasteners: Sheathing shall be attached to framing members using nails or other approved fasteners. Nails shall be driven with the head of the nail flush with the surface of the sheathing. Other approved fasteners shall be driven as required for proper installation of that fastener. See Appendix A for common, box, and sinker nail dimensions.

4.3.6.3.1 Adhesives: Adhesive attachment of shear wall sheathing shall not be used alone, or in combination with mechanical fasteners.

Exception: Approved adhesive attachment systems shall be permitted for wind and seismic design in Seismic Design Categories A, B, and C where $R = 1.5$ and $\Omega_0 = 2.5$, unless other values are approved.

4.3.6.4 Shear Wall Anchorage and Load Path Design of shear wall anchorage and load path shall conform to the requirements of this section, or shall be calculated using principles of mechanics.

4.3.6.4.1 Anchorage for In-plane Shear: Connections shall be provided to transfer the induced unit shear force, ν , into and out of each shear wall.

4.3.6.4.1.1 In-plane Shear Anchorage for Perforated Shear Walls: The maximum induced unit shear force, ν_{max} , transmitted into the top of a perforated shear wall, out of the base of the perforated shear wall at full height sheathing, and into collectors connecting shear wall segments, shall be calculated in accordance with the following:

$$v_{\max} = \frac{V}{C_o \sum L_i} \quad (4.3-9)$$

4.3.6.4.2 Uplift Anchorage at Shear Wall Ends: Where the dead load stabilizing moment is not sufficient to prevent uplift due to overturning moments on the wall (from 4.3.6.1.1 or 4.3.6.1.2), an anchoring device shall be provided at the end of each shear wall.

4.3.6.4.2.1 Uplift Anchorage for Perforated Shear Walls: In addition to the requirements of 4.3.6.4.2, perforated shear wall bottom plates at full height sheathing shall be anchored for a uniform uplift force, t , equal to the unit shear force, v_{\max} , determined in 4.3.6.4.1.1, or calculated by rational analysis.

4.3.6.4.3 Anchor Bolts: Foundation anchor bolts shall have a steel plate washer under each nut not less than 0.229"x3"x3" in size. The hole in the plate washer shall be permitted to be diagonally slotted with a width of up to 3/16" larger than the bolt diameter and a slot length not to exceed 1-3/4", provided a standard cut washer (see Appendix A) is placed between the plate washer and the nut. The plate washer shall extend to within 1/2" of the edge of the bottom plate on the side(s) with sheathing or other material with nominal unit shear capacity greater than 400 plf for wind or seismic.

Exception: Standard cut washers shall be permitted to be used where anchor bolts are designed to resist shear only and the following requirements are met:

- The shear wall is designed in accordance with provisions of 4.3.5.1 with required uplift anchorage at shear wall ends sized to resist overturning neglecting dead load stabilizing moment.
- Shear wall aspect ratio, $h:b$, does not exceed 2:1.
- The nominal unit shear capacity of the shear wall does not exceed 980 plf for seismic or 1370 plf for wind.

4.3.6.4.4 Load Path: A load path to the foundation shall be provided for uplift, shear, and compression forces. Elements resisting shear wall forces contributed by multiple stories shall be designed for the sum of forces contributed by each story.

4.3.7 Shear Wall Systems

4.3.7.1 Wood Structural Panel Shear Walls: Shear walls sheathed with wood structural panel sheathing shall be permitted to be used to resist seismic and wind forces. The size and spacing of fasteners at shear wall boundaries and panel edges shall be as provided in Table 4.3A. The shear wall shall be constructed as follows:

1. Panels shall not be less than 4' x 8', except at boundaries and changes in framing. All edges of all panels shall be supported by and fastened to framing members or blocking.

Exception: Horizontal blocking shall be permitted to be omitted, provided that the shear wall is designed in accordance with all of the following:

- The deflection of the unblocked wood structural panel shear wall shall be permitted to be calculated in accordance with Section 4.3.2.2.
 - The strength of the unblocked wood structural panel shear wall is determined in accordance with Section 4.3.3.2, and
 - Specified nail spacing at supported edges is no closer than 6" o.c.
2. Nails shall be located at least 3/8" from the panel edges. Maximum nail spacing at panel edges shall be 6" on center.
 3. Nails along intermediate framing members shall be the same size as nails specified for panel edge nailing. At intermediate framing members, the maximum nail spacing shall be 6" on center.

Exception: Where panels are thicker than 7/16" or studs are spaced less than 24" on center, the maximum nail spacing shall be 12" on center.

4. The width of the nailed face of framing members and blocking shall be 2" nominal or greater at adjoining panel edges except that a 3" nominal or greater width at adjoining panel edges and staggered nailing at all panel edges are required where:
 - a. Nail spacing of 2" on center or less at adjoining panel edges is specified, or
 - b. 10d common nails having penetration into

- framing members and blocking of more than 1-1/2" are specified at 3" on center, or less at adjoining panel edges, or
- c. Required nominal unit shear capacity on either side of the shear wall exceeds 700 plf in Seismic Design Category D, E, or F.

Exception: Where the width of the nailed face of framing members is required to be 3" nominal, two framing members that are 2" in nominal thickness shall be permitted to be used provided they are fastened together with fasteners designed in accordance with the *NDS* to transfer the induced shear between members. When fasteners connecting the two framing members are spaced less than 4" on center, they shall be staggered.

5. Maximum stud spacing shall be 24" on center.
6. Wood structural panels shall conform to the requirements for its type in DOC PS 1 or PS 2.

4.3.7.2 Shear Walls using Wood Structural Panels over Gypsum Wallboard or Gypsum Sheathing Board: Shear walls sheathed with wood structural panel sheathing over gypsum wallboard or gypsum sheathing board shall be permitted to be used to resist seismic and wind forces. The size and spacing of fasteners at shear wall boundaries and panel edges shall be as provided in Table 4.3B. The shear wall shall be constructed in accordance with Section 4.3.7.1.

4.3.7.3 Particleboard Shear Walls: Shear walls sheathed with particleboard sheathing shall be permitted to be used to resist wind forces and seismic forces in Seismic Design Categories A, B, and C. The size and spacing of fasteners at shear wall boundaries and panel edges shall be as provided in Table 4.3A. The shear wall shall be constructed as follows:

1. Panels shall not be less than 4' x 8', except at boundaries and changes in framing. All edges of all panels shall be supported by and fastened to framing members or blocking.
2. Nails shall be located at least 3/8" from the panel edges. Maximum nail spacing at panel edges shall be 6" on center.
3. Nails along intermediate framing members shall be the same size as nails specified for panel edge nailing. At intermediate framing members, the maximum nail spacing shall be 6" on center.

Exception: Where panels are thicker than 3/8" or studs are spaced less than 24" on center, the maximum nail spacing shall be 12" on center.

4. The width of the nailed face of framing members and blocking shall be 2" nominal or greater at adjoining panel edges except that a 3" nominal or greater width at adjoining panel edges and staggered nailing at all panel edges are required where:
 - a. Nail spacing of 2" on center or less at adjoining panel edges is specified, or
 - b. 10d common nails having penetration into framing members and blocking of more than 1-1/2" are specified at 3" on center, or less at adjoining panel edges.
5. Maximum stud spacing shall be 24" on center.
6. Particleboard shall conform to ANSI A208.1.

4.3.7.4 Structural Fiberboard Shear Walls: Shear walls sheathed with fiberboard sheathing shall be permitted to be used to resist wind forces and seismic forces in Seismic Design Categories A, B, and C. The size and spacing of fasteners at shear wall boundaries and panel edges shall be as provided in Table 4.3A. The shear wall shall be constructed as follows:

1. Panels shall not be less than 4' x 8', except at boundaries and changes in framing. All edges of all panels shall be supported by and fastened to framing members or blocking.
2. Nails shall be located at least 3/4" from edges of panels at top and bottom plates and at least 3/8" from all other edges of panels. Maximum nail spacing at panel edges shall be 4" on center.
3. Nails along intermediate framing members and blocking shall be the same size as installed at the panel edges. Maximum nail spacing shall be 6" on center.
4. The width of the nailed face of framing members and blocking shall be 2" nominal or greater at adjoining panel edges.
5. Maximum stud spacing shall be 16" on center.
6. Fiberboard sheathing shall conform to ASTM C 208.

4.3.7.5 Gypsum Wallboard, Gypsum Base for Veneer Plaster, Water-Resistant Gypsum Backing Board, Gypsum Sheathing Board, Gypsum Lath and Plaster,

or Portland Cement Plaster Shear Walls: Shear walls sheathed with gypsum wallboard, gypsum base for veneer plaster, water-resistant gypsum backing board, gypsum sheathing board, gypsum lath and plaster, or portland cement plaster shall be permitted to be used to resist wind forces and seismic forces in Seismic Design Categories A, B, C, and D. End joints of adjacent courses of gypsum wallboard or sheathing shall not occur over the same stud. The size and spacing of fasteners at shear wall boundaries, panel edges, and intermediate supports shall be as provided in Table 4.3C. Nails shall be located at least 3/8" from the edges and ends of panels. The width of the nailed face of framing members and blocking shall be 2" nominal or greater.

4.3.7.5.1 Gypsum Wallboard, Gypsum Base for Veneer Plaster, Water-Resistant Gypsum Backing Board: Gypsum wallboard, gypsum base for veneer plaster, or water resistant gypsum backing board shall be applied parallel or perpendicular to studs. Gypsum wallboard shall conform to ASTM C 1396 and shall be installed in accordance with ASTM C 840. Gypsum base for veneer plaster shall conform to ASTM C 1396 and shall be installed in accordance with ASTM C 844. Water-resistant gypsum backing board shall conform to ASTM C 1396 and shall be installed in accordance with ASTM C 840.

4.3.7.5.2 Gypsum Sheathing Board: Four-foot-wide pieces of gypsum sheathing board shall be applied parallel or perpendicular to studs. Two-foot-wide pieces of gypsum sheathing board shall be applied perpendicular to the studs. Gypsum sheathing board shall conform to ASTM C 1396 and shall be installed in accordance with ASTM C 1280.

4.3.7.5.3 Gypsum Lath and Plaster: Gypsum lath shall be applied perpendicular to the studs. Gypsum lath shall conform to ASTM C 1396 and shall be installed in accordance with ASTM C 841. Gypsum plaster shall conform to the requirements of ASTM C 28.

4.3.7.5.4 Expanded Metal or Woven Wire Lath and Portland Cement: Expanded metal or woven wire lath and portland cement shall conform to ASTM C 847, ASTM C 1032, and ASTM C 150 and shall be installed in accordance with ASTM C 926 and ASTM

C 1063. Metal lath and lath attachments shall be of corrosion-resistant material.

4.3.7.6 Shear Walls Diagonally Sheathed with Single-Layer of Lumber: Single diagonally sheathed lumber shear walls shall be permitted to be used to resist wind forces and seismic forces in Seismic Design Categories A, B, C, and D. Single diagonally sheathed lumber shear walls shall be constructed of minimum 1" thick nominal sheathing boards laid at an angle of approximately 45° to the supports. End joints in adjacent boards shall be separated by at least one stud space and there shall be at least two boards between joints on the same support. Nailing of diagonally sheathed lumber shear walls shall be in accordance with Table 4.3D.

4.3.7.7 Shear Walls Diagonally Sheathed with Double-Layer of Lumber: Double diagonally sheathed lumber shear walls shall be permitted to be used to resist wind forces and seismic forces in Seismic Design Categories A, B, C, and D. Double diagonally sheathed lumber shear walls shall be constructed of two layers of 1" thick nominal diagonal sheathing boards laid perpendicular to each other on the same face of the supporting members. Nailing of diagonally sheathed lumber shear walls shall be in accordance with Table 4.3D.

4.3.7.8 Shear Walls Horizontally Sheathed with Single-Layer of Lumber: Horizontally sheathed lumber shear walls shall be permitted to be used to resist wind forces and seismic forces in Seismic Design Categories A, B, and C. Horizontally sheathed lumber shear walls shall be constructed of minimum 1" thick nominal sheathing boards applied perpendicular to the supports. End joints in adjacent boards shall be separated by at least one stud space and there shall be at least two boards between joints on the same support. Nailing of horizontally sheathed lumber shear walls shall be in accordance with Table 4.3D.

4.3.7.9 Shear Walls Sheathed with Vertical Board Siding: Vertical board siding shear walls shall be permitted to be used to resist wind forces and seismic forces in Seismic Design Categories A, B, and C. Vertical board siding shear walls shall be constructed of minimum 1" thick nominal sheathing boards applied directly to studs and blocking. Nailing of vertical board siding shear walls shall be in accordance with Table 4.3D.

Table 4.3A Nominal Unit Shear Capacities for Wood-Frame Shear Walls^{1,3,6,7}

Wood-based Panels⁴

Sheathing Material	Minimum Nominal Panel Thickness (in.)	Minimum Fastener Penetration in Framing Member or Blocking (in.)	Fastener Type & Size	A SEISMIC										B WIND							
				Panel Edge Fastener Spacing (in.)										Panel Edge Fastener Spacing (in.)							
				6		4		3		2		2		6		4		3		2	
V _s (plf)	G _a (kips/in.)	V _s (plf)	G _a (kips/in.)	V _s (plf)	G _a (kips/in.)	V _s (plf)	G _a (kips/in.)	V _s (plf)	G _a (kips/in.)	V _s (plf)	G _a (kips/in.)	V _s (plf)	G _a (kips/in.)	V _s (plf)	G _a (kips/in.)	V _s (plf)	G _a (kips/in.)	V _s (plf)	G _a (kips/in.)		
Wood Structural Panels - Structural ^{4,5}	5/16	1-1/4	Nail (common or galvanized box) 6d	OSB	PLY	OSB	PLY	OSB	PLY	OSB	PLY	OSB	PLY	OSB	PLY	OSB	PLY	OSB	PLY	OSB	PLY
	3/8 ²	1-3/8		400	13	10	600	18	13	780	23	16	1020	35	22	560	840	1090	1430	1430	1430
	7/16 ²	15/32		460	19	14	720	24	17	920	30	20	1220	43	24	645	1010	1290	1710	1710	1710
	15/32	1-1/2		510	16	13	790	21	16	1010	27	19	1340	40	24	715	1105	1415	1875	1875	1875
Wood Structural Panels - Sheathing ^{4,5}	5/16	1-1/4	Nail (common or galvanized box) 6d	OSB	PLY	OSB	PLY	OSB	PLY	OSB	PLY	OSB	PLY	OSB	PLY	OSB	PLY	OSB	PLY	OSB	PLY
	3/8	1-3/8		680	22	16	1020	29	20	1330	36	22	1740	51	28	950	1430	1860	2435	2435	2435
	7/16 ²	15/32		360	13	9.5	540	18	12	700	24	14	900	37	18	505	755	980	1260	1260	1260
	15/32	1-1/2		400	11	8.5	600	15	11	780	20	13	1020	32	17	560	840	1090	1430	1430	1430
Plywood Siding	5/16	1-1/4	Nail (galvanized casing) 6d	OSB	PLY	OSB	PLY	OSB	PLY	OSB	PLY	OSB	PLY	OSB	PLY	OSB	PLY	OSB	PLY	OSB	PLY
	3/8	1-3/8		440	17	12	640	25	15	820	31	17	1060	45	20	615	895	1150	1485	1485	1485
	7/16 ²	15/32		480	15	11	700	22	14	900	28	17	1170	42	21	670	980	1260	1640	1640	1640
	15/32	1-1/2		520	13	10	760	19	13	980	25	15	1280	39	20	730	1065	1370	1790	1790	1790
Particleboard Sheathing - (M-S "Exterior Glue" and M-2 "Exterior Glue")	5/16	1-1/4	Nail (common or galvanized box) 6d	OSB	PLY	OSB	PLY	OSB	PLY	OSB	PLY	OSB	PLY	OSB	PLY	OSB	PLY	OSB	PLY	OSB	PLY
	3/8	1-3/8		620	22	14	920	30	17	1200	37	19	1540	52	23	870	1290	1680	2155	2155	2155
	7/16 ²	15/32		680	19	13	1020	26	16	1330	33	18	1740	48	22	950	1430	1860	2435	2435	2435
	15/32	1-1/2		280	13	10	420	16	11	550	17	12	720	21	11	390	590	770	1010	1010	1010
Structural Fiberboard Sheathing	1/2	1-1/2	Nail (galvanized roofing) 11 ga. galv. roofing nail (0.120" x 1-1/2" long x 7/16" head)	OSB	PLY	OSB	PLY	OSB	PLY	OSB	PLY	OSB	PLY	OSB	PLY	OSB	PLY	OSB	PLY	OSB	PLY
	5/8	1-3/8		340	4.0	4.0	360	17	14	460	19	14	600	22	11	335	505	645	840	840	840
	25/32	1-1/2		260	18	14	380	20	15	480	21	15	630	23	12	365	530	670	880	880	880
	25/32	1-3/8		280	18	14	420	20	15	540	22	15	700	24	12	390	590	755	980	980	980
Structural Fiberboard Sheathing	1/2	1-1/2	Nail (galvanized roofing) 11 ga. galv. roofing nail (0.120" x 1-1/2" long x 7/16" head)	OSB	PLY	OSB	PLY	OSB	PLY	OSB	PLY	OSB	PLY	OSB	PLY	OSB	PLY	OSB	PLY	OSB	PLY
	5/8	1-3/8		370	21	15	550	23	17	720	24	16	920	25	13	520	770	1010	1290	1290	1290
	25/32	1-1/2		400	21	15	610	23	17	790	24	16	1040	26	13	560	855	1105	1455	1455	1455
	25/32	1-3/8		340	4.0	4.0	340	4.0	4.0	460	5.0	5.0	520	5.5	5.5	475	645	730	730	730	730

1. Nominal unit shear values shall be adjusted in accordance with 4.3.3 to determine ASD allowable unit shear capacity and LRFD factored unit resistance. For general construction requirements see 4.3.6. For specific requirements, see 4.3.7.1 for wood structural panel shear walls, 4.3.7.2 for particleboard shear walls, and 4.3.7.3 for fiberboard shear walls. See Appendix A for common and box nail dimensions.

2. Shears are permitted to be increased to values shown for 15/32 inch sheathing with same nailing provided (a) studs are spaced a maximum of 16 inches on center, or (b) panels are applied with long dimension across studs.

3. For species and grades of framing other than Douglas-Fir-Larch or Southern Pine, reduced nominal unit shear capacities shall be determined by multiplying the tabulated nominal unit shear capacity by the Specific Gravity Adjustment Factor = $[1 - (0.5 - G)]$, where G = Specific Gravity of the framing lumber from the NDS (Table 11.3.2A). The Specific Gravity Adjustment Factor shall not be greater than 1.

4. Apparent shear stiffness values G_a are based on nail slip in framing with moisture content less than or equal to 19% at time of fabrication and panel stiffness values for shear walls constructed with either OSB or 3-ply plywood panels. When 4-ply or 5-ply plywood panels or composite panels are used, G_a values shall be permitted to be increased by 1.2.

5. Where moisture content of the framing is greater than 19% at time of fabrication, G_a values shall be multiplied by 0.5.

6. Where panels are applied on both faces of a shear wall and nail spacing is less than 6" on center on either side, panel joints shall be offset to fall on different framing members. Alternatively, the width of the nailed face of framing members shall be 3" nominal or greater at adjoining panel edges and nails at all panel edges shall be staggered.

7. Galvanized nails shall be hot-dipped or tumbled.

Table 4.3B Nominal Unit Shear Capacities for Wood-Frame Shear Walls^{1,2,5,6}**Wood Structural Panels Applied over 1/2" or 5/8" Gypsum Wallboard or Gypsum Sheathing Board**

Sheathing Material	Minimum Nominal Panel Thickness (in.)	Minimum Fastener Penetration in Framing Member or Blocking (in.)	Fastener Type & Size	A SEISMIC						B WIND							
				Panel Edge Fastener Spacing (in.)						Panel Edge Fastener Spacing (in.)							
				6		4		3		2		6		4		3	
Wood Structural Panels - Structural ^{3,4}	5/16 3/8, 7/16, 15/32	1-1/4 1-3/8	Nail (common or galvanized box)	V_s (plf)	G_a (kips/in.)	V_s (plf)	G_a (kips/in.)	V_s (plf)	G_a (kips/in.)	V_s (plf)	G_a (kips/in.)	V_s (plf)	G_a (kips/in.)	V_w (plf)	V_w (plf)	V_w (plf)	V_w (plf)
Wood Structural Panels - Sheathing ^{3,4}	5/16 3/8	1-1/4	Nail (common or galvanized casing)	400	13	10	600	18	13	780	23	16	1020	35	22	560	1430
Plywood Siding	5/16 3/8	1-1/4 1-3/8	Nail (galvanized casing)	560	14	11	860	18	14	1100	24	17	1460	37	23	785	2045
				360	13	9.5	540	18	12	700	24	14	900	37	18	505	1260
				400	11	8.5	600	15	11	780	20	13	1020	32	17	560	1430
				520	13	10	760	19	13	980	25	15	1280	39	20	730	1790
				280	13	13	420	16	16	550	17	17	720	21	21	390	1010
				320	16	16	480	18	18	620	20	20	820	22	22	450	1150

- Nominal unit shear capacities shall be adjusted in accordance with 4.3.3 to determine ASD allowable unit shear capacity and LRFD factored unit resistance. For general construction requirements see 4.3.6. For specific requirements, see 4.3.7.1 for wood structural panel shear walls. See Appendix A for common and box nail dimensions.
- For species and grades of framing other than Douglas-Fir-Larch or Southern Pine, reduced nominal unit shear capacities shall be determined by multiplying the tabulated nominal unit shear capacity by the Specific Gravity Adjustment Factor = $[1 - (0.5 - G)]$, where G = Specific Gravity of the framing lumber from the *MDS* (Table 11.3.2A). The Specific Gravity Adjustment Factor shall not be greater than 1.
- Apparent shear stiffness values, G_a , are based on nail slip in framing with moisture content less than or equal to 19% at time of fabrication and panel stiffness values for shear walls constructed with either OSB or 3 ply plywood panels. When 4-ply or 5-ply plywood panels or composite panels are used, G_a values for plywood shall be permitted to be increased by 1.2.
- Where moisture content of the framing is greater than 19% at time of fabrication, G_a values shall be multiplied by 0.5.
- Where panels are applied on both faces of a shear wall and nail spacing is less than 6" on center on either side, panel joints shall be offset to fall on different framing members. Alternatively, the width of the nailed face of framing members shall be 3" nominal or greater at adjoining panel edges and nails at all panel edges shall be staggered.
- Galvanized nails shall be hot-dipped or tumbled.

Table 4.3C Nominal Unit Shear Capacities for Wood-Frame Shear Walls¹

Gypsum and Portland Cement Plaster

Sheathing Material	Material Thickness	Fastener Type & Size ²	Max. Fastener Edge Spacing (in.) ³	Max. Stud Spacing (in.)	SEISMIC		WIND		
					V _s (plf)	G _a (kips/in)			
Gypsum wallboard, gypsum base for veneer plaster, or water-resistant gypsum backing board	1/2"	5d cooler (0.086" x 1-5/8" long, 15/64" head) or wallboard nail (0.086" x 1-5/8" long, 9/32" head) or 0.120" nail x 1-1/2" long, min 3/8" head	7	24	unblocked	150	4.0	150	
			4	24	unblocked	220	6.0	220	
			7	16	unblocked	200	5.5	200	
			4	16	unblocked	250	6.5	250	
			7	16	blocked	250	6.5	250	
	5/8"	No. 6 Type S or W drywall screws 1-1/4" long	4	16	blocked	300	7.5	300	
			8/12	16	unblocked	120	3.5	120	
			4/16	16	blocked	320	8.0	320	
			4/12	24	blocked	310	8.0	310	
			8/12	16	blocked	140	4.0	140	
Gypsum sheathing board	1/2" x 2' x 8'	6d cooler (0.092" x 1-7/8" long, 1/4" head) or wallboard nail (0.0915" x 1-7/8" long, 19/64" head) or 0.120" nail x 1-3/4" long, min 3/8" head	7	24	unblocked	230	6.0	230	
			4	24	unblocked	290	7.5	290	
			7	16	blocked	290	7.5	290	
			4	16	blocked	350	8.5	350	
			8/12	16	unblocked	140	4.0	140	
	1/2" x 4'	Face ply-6d cooler (0.113" x 2-3/8" long, 0.281" head) or wallboard nail (0.113" x 2-3/8" long, 3/8" head) or 0.120" nail x 2-3/8" long, min 3/8" head	8/12	16	unblocked	180	5.0	180	
			8/12	16	blocked	500	11	500	
			Base: 9	16	blocked				
			Face: 7	16	blocked				
			4	16	unblocked	150	4.0	150	
Gypsum lath, plain or perforated with vertical joints staggered	3/8" lath and 1/2" plaster	0.092" x 1-1/8" long, 19/64" head, gypsum wallboard blue nail or 0.120" nail x 1-1/4" long, min 3/8" head	4	16	unblocked	150	4.0	150	
			4	24	blocked	350	8.5	350	
			7	16	unblocked	200	5.5	200	
			4/7	16	blocked	400	9.5	400	
			5	16	unblocked	360	9.0	360	
	7/8"	0.092" x 1-1/8" long, 19/64" head, gypsum wallboard blue nail or 0.120" nail x 1-1/4" long, min 3/8" head	0.092" x 1-1/8" long, 19/64" head, gypsum wallboard blue nail or 0.120" nail x 1-1/4" long, min 3/8" head	5	16	unblocked	200	5.5	200
				5	16	unblocked	360	9.0	360
				6	16	unblocked			
				0.120" nail x 1-1/2" long, 7/16" head	16	unblocked	360	9.0	360
					16	unblocked			

1. Nominal unit shear capacities shall be adjusted in accordance with 4.3.3 to determine ASD allowable unit shear capacity and LRFD factored unit resistance. For general construction requirements see 4.3.6. For specific requirements, see 4.3.7.4.
 2. Type S or W drywall screws shall conform to requirements of ASTM C 1002.
 3. Where two numbers are given for maximum fastener edge spacing, the first number denotes fastener spacing at the edges and the second number denotes fastener spacing along intermediate framing members.

Table 4.3D Nominal Unit Shear Capacities for Wood-Frame Shear Walls¹**Lumber Shear Walls**

Sheathing Material	Sheathing Nominal Dimensions	Type, Size, and Number of Nails per Board		A		B	
		Nailing at Intermediate Studs (nails/board/support)	Nailing at Shear Wall Boundary Members (nails/board/endl)	v _g (plf)	G _a (kips/in.)	v _w (plf)	WIND
Horizontal Lumber	1x6 & smaller	2-8d common nails (3-8d box nails)	3-8d common nails (5-8d box nails)	100	1.5	140	
Sheathing	1x8 & larger	3-8d common nails (4-8d box nails)	4-8d common nails (6-8d box nails)				
Diagonal Lumber	1x6 & smaller	2-8d common nails (3-8d box nails)	3-8d common nails (5-8d box nails)	600	6.0	840	
Sheathing	1x8 & larger	3-8d common nails (4-8d box nails)	4-8d common nails (6-8d box nails)				
Double Diagonal Lumber	1x6 & smaller	2-8d common nails (3-8d box nails)	3-8d common nails (5-8d box nails)	1200	10	1680	
Sheathing	1x8 & larger	3-8d common nails (4-8d box nails)	4-8d common nails (6-8d box nails)				
Vertical Lumber Siding	1x6 & smaller	2-8d common nails (3-8d box nails)	3-8d common nails (5-8d box nails)	90	1.0	125	
	1x8 & larger	3-8d common nails (4-8d box nails)	4-8d common nails (6-8d box nails)				

1. Nominal unit shear capacities shall be adjusted in accordance with 4.3.3 to determine ASD allowable unit shear capacity and LRF factored unit resistance. For general construction requirements see 4.3.6. For specific requirements, see 4.3.7.5 through 4.3.7.8. See Appendix A for common and box nail dimensions.

4.4 Wood Structural Panels Designed to Resist Combined Shear and Uplift from Wind

4.4.1 Application

Wood structural panel sheathing or siding shall be permitted to be used for simultaneously resisting shear and uplift from wind forces. The ASD allowable unit uplift capacity shall be determined by dividing the tabulated nominal uplift capacity in Table 4.4.1, modified by applicable footnotes, by the ASD reduction factor of 2.0. The LRFD factored unit uplift resistance shall be determined by multiplying the tabulated nominal uplift capacity in Table 4.4.1 modified by applicable footnotes, by a resistance factor, ϕ_z , of 0.65.

4.4.1.1 Nails: Nails in any single row shall not be spaced closer than 3" on center.

4.4.1.2 Panels: Panels shall have a minimum thickness of 7/16" and shall be installed with the strength axis parallel to the studs.

4.4.1.3 Horizontal Joints: All horizontal joints shall occur over common framing members or common blocking and shall meet all other requirements of Section 4.3.

4.4.1.4 Openings: Where windows and doors interrupt wood structural panel sheathing or siding, framing anchors or connectors shall be provided to resist and transfer the appropriate uplift loads around the opening and into the foundation.

4.4.1.5 Sheathing Extending to Top Plate: The following requirements shall apply:

1. The top edge of the wood structural panel shall be attached to the upper top plate. Nail row, end spacing, and edge spacing shall be as shown in Figure 4G.
2. Roof or upper level uplift connectors shall be on the same side of the wall as the sheathing unless other methods are used to prevent twisting of the top plate due to eccentric loading.

4.4.1.6 Sheathing Extending to Bottom Plate or Sill Plate: The following requirements shall apply:

1. The bottom edge of the wood structural panel shall extend to and be attached to the bottom plate or sill plate as shown in Figure 4G.
2. Anchorage of bottom plates or sill plates to the

foundation shall be designed to resist the combined uplift and shear forces developed in the wall. Anchors shall be spaced at 16" on center or less.

- a. Where anchor bolts are used, a minimum 0.229" x 3" x 3" steel plate washer shall be used at each anchor bolt location. The edge of the plate washer shall extend to within 1/2" of the edge of the bottom plate on the sheathed side.
- b. Where other anchoring devices are used to anchor the wall to the foundation, they shall be installed on the same side of the wall as the sheathing unless other approved methods are used.

4.4.1.7 Sheathing Splices:

1. In multi-story applications where the upper story and lower story sheathing adjoin over a common horizontal framing member, the nail spacing shall not be less than 3" o.c. for a single row nor 6" o.c. for a double row in Table 4.4.1 (see Figure 4H).
2. In single or multi-story applications where horizontal joints in the sheathing occur over blocking between studs, nailing of the sheathing to the studs above and below the joint shall be designed to transfer the uplift across the joint (see Figure 4I). The uplift capacity shall not exceed the capacity in Table 4.4.1. Blocking shall be designed in accordance with Section 4.4.1.3 for shear transfer.

Exception: Horizontal blocking and sheathing tension splices placed between studs and backing the horizontal joint shall be permitted to be used to resist both uplift and shear at sheathing splices over studs provided the following conditions are met (see Figure 4J):

- a. Sheathing tension splices shall be made from the same thickness and grade as the shear wall sheathing.
- b. Edges of sheathing shall be nailed to sheathing tension splices using the same nail size and spacing as the sheathing or siding nails at the bottom plate.

4.4.2 Wood Structural Panels Designed to Resist Only Uplift from Wind

Where wood structural panel sheathing or siding is designed to resist only uplift from wind forces, it shall be installed in accordance with Section 4.4.1, except that panels with a minimum thickness of 3/8" shall be permitted when installed with the strength axis parallel

to the studs. The ASD allowable unit uplift shall be determined by dividing the tabulated nominal uplift capacity in Table 4.4.2, modified by applicable footnotes, by the ASD reduction factor of 2.0. The LFRD factored uplift resistance shall be determined by multiplying the tabulated nominal unit uplift capacity in Table 4.4.2, modified by applicable footnotes, by a resistance factor, ϕ_z , of 0.65.

Figure 4G Panel Attachment

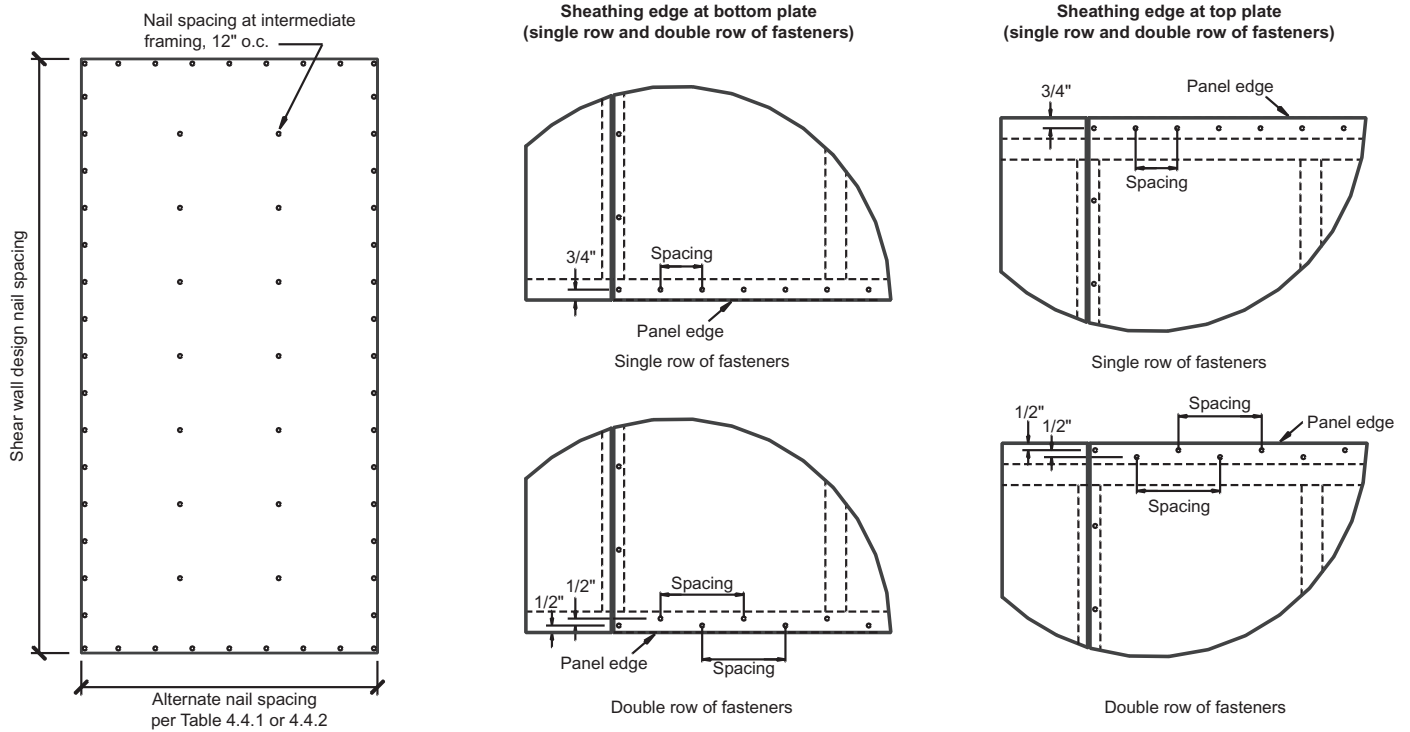

Figure 4H Panel Splice Occurring over Horizontal Framing Member

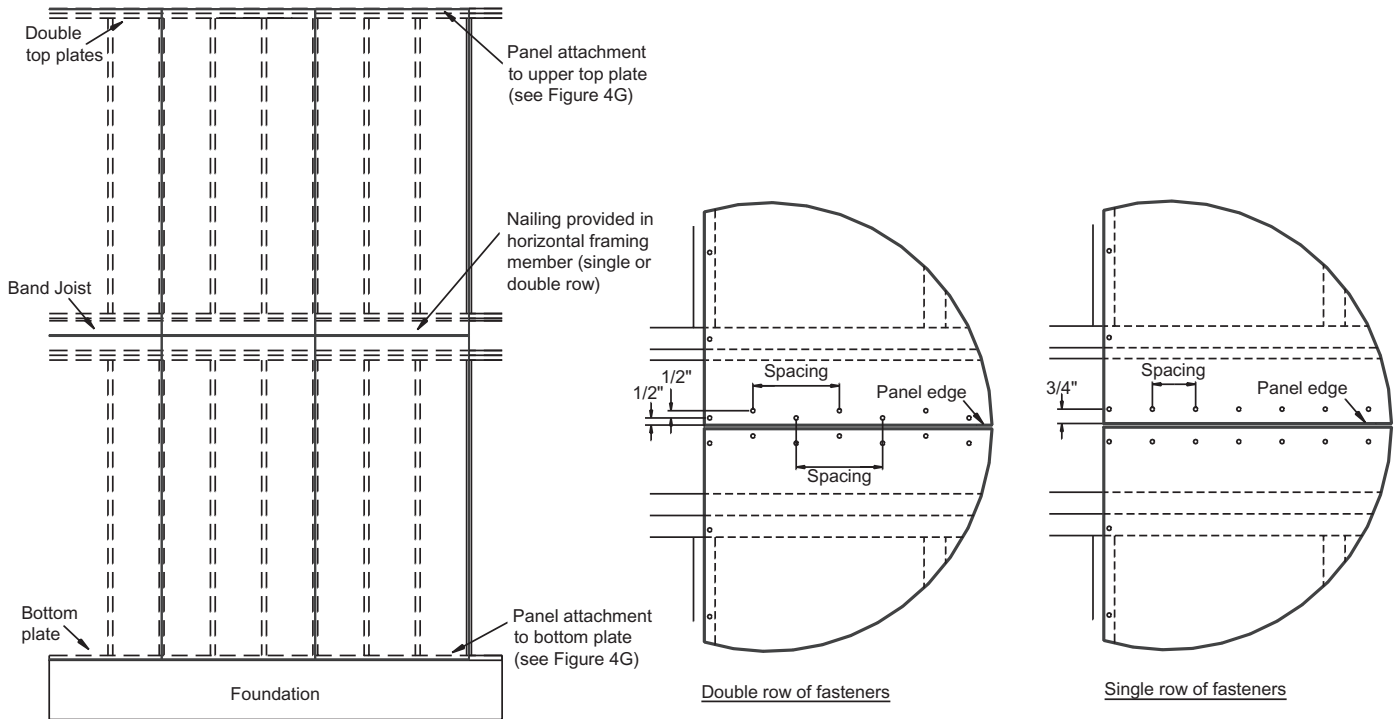

Figure 4I Panel Splice Occurring across Studs

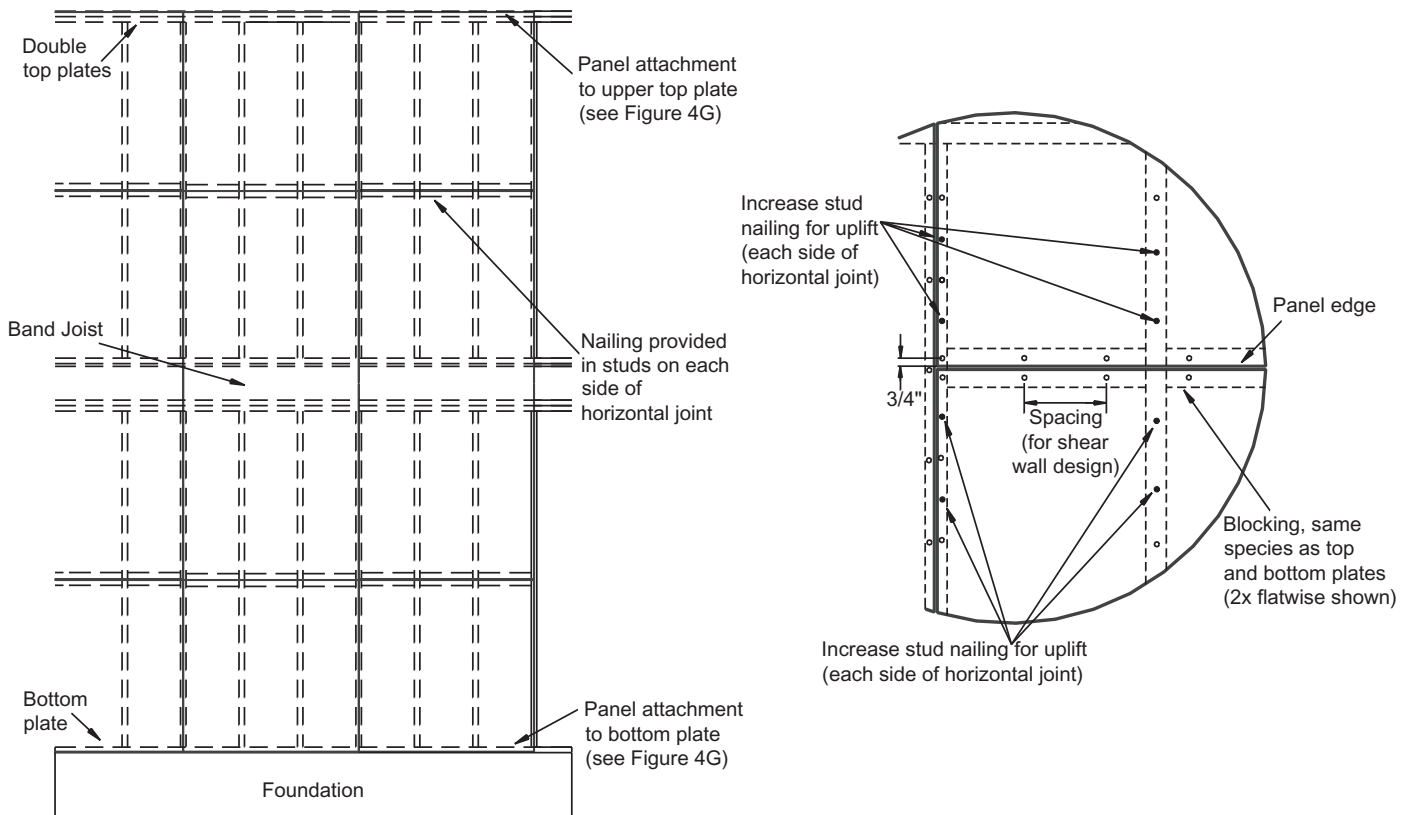

Figure 4J Sheathing Splice Plate (Alternate Detail)

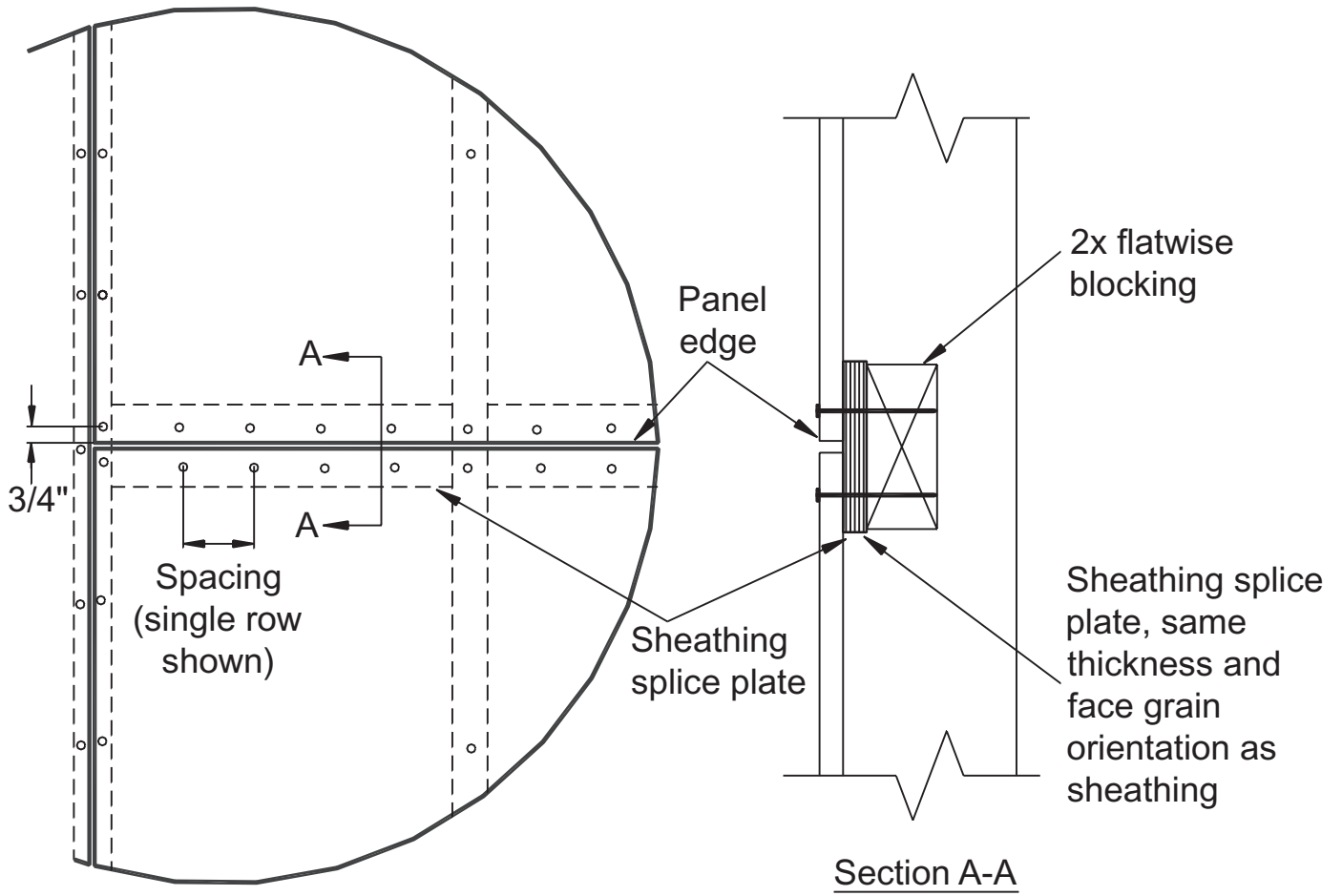

Table 4.4.1 Nominal Uplift Capacity of 7/16" Minimum Wood Structural Panel Sheathing or Siding When Used for Both Shear Walls and Wind Uplift Simultaneously over Framing with a Specific Gravity of 0.42 or Greater ¹

	Nail Spacing Required for Shearwall Design											
	6d Common Nail 6" panel edge spacing 12" field spacing			8d Common Nail 6" panel edge spacing 12" field spacing			8d Common Nail 4" panel edge spacing 12" field spacing			10d Common Nail 6" panel edge spacing 12" field spacing		
	Alternate Nail Spacing at Top and Bottom Plate Edges											
	6"	4"	3"	6"	4"	3"	6"	4"	3"	6"	4"	3"
Uplift Capacity (plf) of Wood Structural Panel Sheathing or Siding ^{2,3}												
Nails-Single Row ⁴	0	168	336	0	216	432	NA	0	216	0	262	524
Nails-Double Row ⁵	336	672	1008	432	864	1296	216	648	1080	524	1048	1572

- Nominal unit uplift capacities shall be adjusted in accordance with 4.4.1 to determine ASD allowable unit uplift capacity and LRFD factored unit resistance. Anchors shall be installed in accordance with this section. See Appendix A for common nail dimensions.
- Where framing has a specific gravity of 0.49 or greater, uplift values in table 4.4.1 shall be permitted to be multiplied by 1.08.
- Where nail size is 6d common or 8d common, the tabulated uplift values are applicable to 7/16" minimum OSB panels or 15/32" minimum plywood with species of plies having a specific gravity of 0.49 or greater. Where nail size is 10d common, the tabulated uplift values are applicable to 15/32" minimum OSB or plywood with a species of plies having a specific gravity of 0.49 or greater. For plywood with other species, multiply the tabulated uplift values by 0.90.
- Wood structural panels shall overlap the top member of the double top plate and bottom plate by 1-1/2" and a single row of fasteners shall be placed 3/4" from the panel edge.
- Wood structural panels shall overlap the top member of the double top plate and bottom plate by 1-1/2". Rows of fasteners shall be 1/2" apart with a minimum edge distance of 1/2". Each row shall have nails at the specified spacing.

Table 4.4.2 Nominal Uplift Capacity of 3/8" Minimum Wood Structural Panel Sheathing or Siding When Used for Wind Uplift Only over Framing with a Specific Gravity of 0.42 or Greater ¹

	6d Common Nail 6" panel edge spacing 12" field spacing			8d Common Nail 6" panel edge spacing 12" field spacing			10d Common Nail 6" panel edge spacing 12" field spacing		
	Alternate Nail Spacing at Top and Bottom Panel Edges								
	6"	4"	3"	6"	4"	3"	6"	4"	3"
	Uplift Capacity (plf) of Wood Structural Panel Sheathing or Siding ^{2,3}								
Nails-Single Row ⁴	320	480	640	416	624	832	500	750	1000
Nails-Double Row ⁵	640	960	1280	832	1248	1664	1000	1500	2000

- Nominal unit uplift capacities shall be adjusted in accordance with 4.4.2 to determine ASD allowable unit uplift capacity and LRFD factored unit resistance. Anchors shall be installed in accordance with this section. See Appendix A for common nail dimensions.
- Where framing has a specific gravity of 0.49 or greater, uplift values in table 4.4.2 shall be permitted to be multiplied by 1.08.
- The tabulated uplift values are applicable to 3/8" minimum OSB panels or plywood with species of plies having a specific gravity of 0.49 or greater. For plywood with other species, multiply the tabulated uplift values by 0.90.
- Wood structural panels shall overlap the top member of the double top plate and bottom plate by 1-1/2" and a single row of fasteners shall be placed 3/4" from the panel edge.
- Wood structural panels shall overlap the top member of the double top plate and bottom plate by 1-1/2". Rows of fasteners shall be 1/2" apart with a minimum edge distance of 1/2". Each row shall have nails at the specified spacing.

Page left blank intentionally

APPENDIX A

Table A1	Standard Common, Box, and Sinker Nails.....	42
Table A2	Standard Cut Washers	42

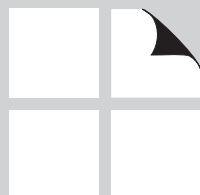



Table A1 Standard Common, Box, and Sinker Nails¹

D = diameter
L = length
H = head diameter

Type		Pennyweight										
		6d	7d	8d	10d	12d	16d	20d	30d	40d	50d	60d
Common	L	2"	2-1/4"	2-1/2"	3"	3-1/4"	3-1/2"	4"	4-1/2"	5"	5-1/2"	6"
	D	0.113"	0.113"	0.131"	0.148"	0.148"	0.162"	0.192"	0.207"	0.225"	0.244"	0.263"
	H	0.266"	0.266"	0.281"	0.312"	0.312"	0.344"	0.406"	0.438"	0.469"	0.5"	0.531"
Box	L	2"	2-1/4"	2-1/2"	3"	3-1/4"	3-1/2"	4"	4-1/2"	5"		
	D	0.099"	0.099"	0.113"	0.128"	0.128"	0.135"	0.148"	0.148"	0.162"		
	H	0.266"	0.266"	0.297"	0.312"	0.312"	0.344"	0.375"	0.375"	0.406"		
Sinker	L	1-7/8"	2-1/8"	2-3/8"	2-7/8"	3-1/8"	3-1/4"	3-3/4"	4-1/4"	4-3/4"		5-3/4"
	D	0.092"	0.099"	0.113"	0.12"	0.135"	0.148"	0.177"	0.192"	0.207"		0.244"
	H	0.234"	0.250"	0.266"	0.281"	0.312"	0.344"	0.375"	0.406"	0.438"		0.5"

1. Tolerances specified in ASTM F 1667. Typical shape of common, box, and sinker nails shown. See ASTM F1667 for other nail types.

Table A2 Standard Cut Washers

Dimensions of Standard Cut Washers ¹			
Nominal Washer Size (in.)	A	B	C
	Inside Diameter (in.)	Outside Diameter (in.)	Thickness (in.)
	Basic	Basic	Basic
3/8	0.438	1.000	0.083
1/2	0.562	1.375	0.109
5/8	0.688	1.750	0.134
3/4	0.812	2.000	0.148
7/8	0.938	2.250	0.165
1	1.062	2.500	0.165

1. For other standard cut washers, see ANSI/ASME B18.22.1. Tolerances are provided in ANSI/ASME B18.22.1.

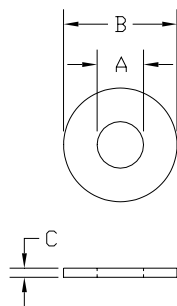

REFERENCES

R

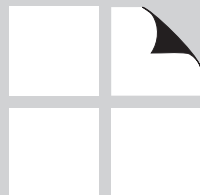

AMERICAN FOREST & PAPER ASSOCIATION

References

1. ASD/LRFD Manual for Engineered Wood Construction, American Forest & Paper Association, Washington, DC, 2005.
2. ANSI A208.1-99, Particleboard, ANSI, New York, NY, 1999.
3. ANSI/ASME B18.22.1, Plain Washers, American Society of Mechanical Engineers, New York, NY, 1965.
4. ANSI/CPA A135.6 Hardboard Siding, Composite Panel Association, Gaithersburg, MD, 2006.
5. ASTM C1396/C1396M-06a Standard Specification for Gypsum Board, ASTM, West Conshohocken, PA, 2006.
6. ASTM C 28/C 28M-01, Standard Specification for Gypsum Plasters, ASTM, West Conshohocken, PA, 2001.
7. ASTM C 150-00, Standard Specification for Portland Cement, ASTM, West Conshohocken, PA, 2000.
8. ASTM C 208-95(2001), Standard Specification for Cellulosic Fiber Insulation Board, ASTM, West Conshohocken, PA, 2001.
9. ASTM C 840-01, Standard Specification for Application and Finishing of Gypsum Board, ASTM, West Conshohocken, PA, 2001.
10. ASTM C 841-99, Standard Specification for Installation of Interior Lathing and Furring, ASTM, West Conshohocken, PA, 1999.
11. ASTM C 844-99, Standard Specification for Application of Gypsum Base to Receive Gypsum Veneer Plaster, ASTM, West Conshohocken, PA, 1999.
12. ASTM C 847-95 (2000), Standard Specification for Metal Lath, ASTM, West Conshohocken, PA, 2000.
13. ASTM C 926-98a, Standard Specification for Application of Portland Cement Based Plaster, ASTM, West Conshohocken, PA, 1998.
14. ASTM C 1002 Standard Specification for Steel Self-Piercing Tapping Screws for the Application of Gypsum Panel Products or Metal Plaster Bases to Wood Studs or Steel Studs, ASTM, West Conshohocken, PA, 2007.
15. ASTM C 1032-96, Standard Specification for Woven Wire Plaster Base, ASTM, West Conshohocken, PA, 1996.
16. ASTM C 1063-99, Standard Specification for Installation of Lathing and Furring to Receive Interior and Exterior Portland Cement-Based Plaster, ASTM, West Conshohocken, PA, 1999.
17. ASTM C 1280-99, Standard Specification for Application of Gypsum Sheathing, ASTM, West Conshohocken, PA, 1999.
18. ASTM F 1667-03, Standard for Driven Fasteners: Nails, Spikes, and Staples, ASTM, West Conshohocken, PA, 2003.
19. National Design Specification (NDS) for Wood Construction, American Forest & Paper Association, Washington, DC, 2005.
20. PS 1-07 Structural Plywood, United States Department of Commerce, National Institute of Standards and Technology, Gaithersburg, MD, 2007.
21. PS 2-04 Performance Standard for Wood-Based Structural Use Panels, United States Department of Commerce, National Institute of Standards and Technology, Gaithersburg, MD, 2004.

SDPWS COMMENTARY

C2	General Design Requirements	47
C3	Members and Connections	49
C4	Lateral Force-Resisting Systems	53
	Commentary References	77

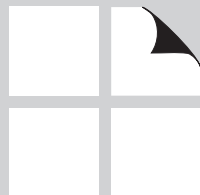
C

FOREWORD

The *Special Design Provisions for Wind and Seismic (SDPWS)* document was first issued in 2002. It contains provisions for materials, design, and construction of wood members, fasteners, and assemblies to resist wind and seismic forces. The 2008 edition is the third edition of this publication.

The Commentary to the *SDPWS* is provided herein and includes background information for most sections as well as sample calculations for each of the design value tables.

The Commentary follows the same subject matter organization as the *SDPWS*. Discussion of a particular provision in the *SDPWS* is identified in the Commentary by the same section or subsection. When available, references to more detailed information on specific subjects are included.

In developing the provisions of the *SDPWS*, data and experience with structures in-service has been carefully evaluated by the AF&PA Wood Design Standards Committee for the purpose of providing a standard of practice. It is intended that this document be used in conjunction with competent engineering design, accurate fabrication, and adequate supervision of construction. Therefore AF&PA does not assume any responsibility for errors or omissions in the *SDPWS* and *SDPWS Commentary*, nor for engineering designs and plans prepared from it.

Inquiries, comments and suggestions from the readers of this document are invited.

American Forest & Paper Association

C2 GENERAL DESIGN REQUIREMENTS

C2.1 General

C2.1.1 Scope

Allowable stress design (ASD) and load and resistance factor design (LRFD) provisions are applicable for the design of wood members and systems to resist wind and seismic loads. For other than short-term wind and seismic loads (10-minute basis), adjustment of design capacities for load duration or time effect shall be in accordance with the *National Design Specification® (NDS®) for Wood Construction* (6).

C2.1.2 Design Methods

Both ASD and LRFD (also referred to as strength design) formats are addressed by reference to the *National Design Specification (NDS) for Wood Construction* (6) for

design of wood members and connections. The design of elements throughout a structure will generally utilize either the ASD or LRFD format; however, specific requirements to use a single design format for all elements within a structure are not included. The suitability of mixing formats within a structure is the responsibility of the designer in compliance with requirements of the authority having jurisdiction. *ASCE 7 – Minimum Design Loads for Buildings and Other Structures* (5) limits mixing of design formats to cases where there are changes in materials.

C2.2 Terminology

ASD Reduction Factor: This term denotes the specific adjustment factor used to convert nominal design values to ASD reference design values.

Nominal Strength: Nominal strength (or nominal capacity) is used to provide a common reference point from which to derive ASD or LRFD reference design values. For wood structural panels, tabulated nominal unit shear capacities for wind, v_w , (nominal strength) were derived using ASD tabulated values from industry design documents and model building codes (2, 18, 19, and 20) times a factor of 2.8. The factor of 2.8, based on minimum performance requirements (8), has commonly been considered the target minimum safety factor associated with ASD unit shear capacity for wood structural panel shear walls and diaphragms. To be consistent with the ratio of wind and seismic design capacities for wood structural panel shear walls and diaphragms in model building codes (2), the nominal unit shear capacity for seismic, v_s , was derived by dividing the nominal unit shear capacity for wind by 1.4. For fiberboard and lumber shear walls and lumber diaphragms, similar assumptions were used.

For shear walls utilizing other materials, ASD unit shear capacity values from model building codes (2) and

industry design documents (20) were multiplied by 2.0 to develop nominal unit shear capacity values for both wind and seismic.

Resistance Factor: For LRFD, resistance factors are assigned to various wood properties with only one factor for each stress mode (i.e. bending, shear, compression, tension, and stability). Theoretically, the magnitude of a resistance factor is considered to, in part, reflect relative variability of wood product properties. However, for wood design provisions, actual differences in product variability are already embedded in the reference design values. This is due to the fact that typical reference design values are based on a statistical estimate of a near-minimum value (5th percentile).

The following resistance factors are used in the *SDPWS*: a) sheathing in-plane shear, $\phi_p = 0.80$, b) sheathing out-of-plane bending $\phi_b = 0.85$, and c) connections, $\phi_z = 0.65$. LRFD resistance factors have been determined by an ASTM consensus standard committee (16). The factors were derived to achieve a target reliability index, β , of 2.4 for a reference design condition. Examination of other design conditions verified a reasonable range of reliability indices would be achieved by application of ASTM D 5457



(16) resistance factors. Because the target reliability index was selected based on historically acceptable design practice, there is virtually no difference between designs using either ASD or LRFD at the reference design condition (16). However, differences will occur due to varying ASD and LRFD load factors and under certain load combinations. It should be noted that this practice (of calibrating LRFD to historically acceptable design) was also used by other major building material groups. The calibration calculation between ASD and LRFD for in-plane shear considered the following:

Wind Design

$$\text{ASD: } \frac{R_{wind}}{2.0} \geq 1.0W \quad (\text{C2.2-1})$$

$$\text{LRFD: } \phi_D R_{wind} \geq 1.6W \quad (\text{C2.2-2})$$

Seismic Design

$$\text{ASD: } \frac{R_{seismic}}{2.0} \geq 0.7E \quad (\text{C2.2-3})$$

$$\text{LRFD: } \phi_D R_{seismic} \geq 1.0E \quad (\text{C2.2-4})$$

R_{wind} = nominal capacity for wind

$R_{seismic}$ = nominal capacity for seismic

2.0 = ASD Reduction Factor

ϕ_D = resistance factor for in-plane shear of shear walls and diaphragms

W = wind load effect

E = earthquake load effect

From Equation C2.2-1 and Equation C2.2-2, the value of ϕ_D that produces exact calibration between ASD and LRFD design for wind is:

$$\phi_D = \frac{1.6W}{R_{wind}} = \frac{1.6W}{1.0W(2.0)} = 0.80 \quad (\text{C2.2-5})$$

From Equation C2.2-3 and Equation C2.2-4, the value of ϕ_D that produces exact calibration between ASD and LRFD design for seismic is:

$$\phi_D = \frac{1.0E}{R_{seismic}} = \frac{1.0E}{0.7E(2.0)} = 0.70 \quad (\text{C2.2-6})$$

A single resistance factor, ϕ_D , of 0.80 for wind and seismic design was chosen by both the ASTM and the SDPWS consensus committees because the added complexity of utilizing two separate factors was not warranted given the small relative difference in calibrations. The same approach was used for earlier calibrations and resulted in $\phi_D = 0.65$ as shown in *ASCE 16-95* and the *2001 SDPWS*; however, the calibration was tied to load combinations given in *ASCE 7-88* resulting in a value of $\phi_D = 0.65$.

Recalling that nominal unit shear capacities for seismic were derived by dividing the nominal unit shear capacity for wind by 1.4 (see C2.2 Nominal Strength), the “Effective ϕ_D ” for seismic shear resistance is approximately 0.57:

$$\text{“Effective } \phi_D \text{”} = \frac{0.80}{1.4} = 0.57 \quad (\text{C2.2-7})$$

where:

0.80 = ϕ_D from Equation C2.2-5 calibration for wind

1.4 = ratio of R_{wind} to $R_{seismic}$ ($R_{wind}/R_{seismic}$)

From Equation C.2.2-7, LRFD factored unit shear resistance for seismic is approximately 0.57 times the minimum target strength (e.g. R_{wind}) set by underlying product standards.

C3 MEMBERS AND CONNECTIONS

C3.1 Framing

C3.1.1 Wall Framing

Wall studs sheathed on both sides are stronger and stiffer in flexure (i.e., wind loads applied perpendicular to the wall plane) than those in similar, unsheathed wall assemblies. The enhanced performance or “system effect” is recognized in wood design with the repetitive member factor, C_r , which accounts for effects of partial composite action and load-sharing (1). Wall stud bending stress increase factors in *SDPWS* Table 3.1.1.1 are applicable for out-of-plane wind loads and were derived based on wall tests (9). A factor of 1.56 was determined for a wall configured as follows:

Framing	2x4 Stud grade Douglas fir studs at 16" o.c.
Interior Sheathing	1/2" gypsum wallboard attached with 4d cooler nails at 7" o.c. edge and 10" o.c. field (applied vertically).
Exterior Sheathing	3/8" rough sanded 303 siding attached with 6d box nails at 6" o.c. edge and 12" o.c. field (applied vertically).

For design purposes, a slightly more conservative value of 1.5 was chosen to represent a modified 2x4 stud wall system as follows:

C3.2 Sheathing

Nominal uniform load capacities in *SDPWS* Tables 3.2.1 and 3.2.2 assume a two-span continuous condition. Out-of-plane sheathing capacities are often tabulated in other documents on the basis of a three-span continuous condition. Although the three-span continuous condition results in higher capacity, the more conservative two-span continuous condition was selected because this condition frequently exists at building end zones where the largest wind forces occur.

Framing	2x4 Stud grade Douglas fir studs at 24" o.c.
Interior Sheathing	1/2" gypsum wallboard attached with 5d cooler nails at 7" o.c. edge and 10" o.c. field (applied vertically).
Exterior Sheathing	3/8" wood structural panels attached with 8d common nails at 6" o.c. edge and 12" o.c. field (blocked).

For other stud depths, the wall stud bending stress increase factor was assumed to be proportional to the relative stiffness (EI) of the stud material. A repetitive member factor of 1.15 (6) was assumed for a 2x12 stud in a wall system and Equation C3.1.1-1 was used to interpolate repetitive member factors for 2x6, 2x8, and 2x10 studs:

$$C_r = 1.15 \left[\frac{178 \text{ in}^4}{I_{stud}} \right]^{0.076} \quad (\text{C3.1.1-1})$$

Slight differences between calculated C_r values and those appearing in *SDPWS* Table 3.1.1.1 are due to rounding.

Examples C3.2.1-1 and C3.2.1-2 illustrate how values in *SDPWS* Table 3.2.1 were generated using wood structural panel out-of-plane bending and shear values given in Tables C3.2A and C3.2B. Although the following two examples are for *SDPWS* Table 3.2.1, the same procedure can be used to generate values shown in *SDPWS* Table 3.2.2.



Table C3.2C provides out-of-plane bending strength capacities for cellulosic fiberboard sheathing based on minimum modulus of rupture criteria in ASTM C 208. Nominal uniform load capacities for cellulosic fiberboard sheathing in *SDPWS* Table 3.2.1 can be derived using the same procedure as described in Example C3.2.1-1.

Table C3.2A Wood Structural Panel Dry Design Bending Strength Capacities

Span Rating: <i>Sheathing</i>	Bending Strength, F_b , S (lb-in./ft width)	
	Strength Axis Perpendicular to Supports	Strength Axis Parallel to Supports
24/0	250	54
24/16	320	64
32/16	370	92
40/20	625	150
48/24	845	225

Table C3.2B Wood Structural Panel Dry Shear Capacities in the Plane

Span Rating: <i>Sheathing</i>	Shear in the Plane, F_s [lb/Q] (lb/ft width)
	Strength Axis Either Perpendicular or Parallel to Supports
24/0	130
24/16	150
32/16	165
40/20	205
48/24	250

Table C3.2C Cellulosic Fiberboard Sheathing Design Bending Strength Capacities

Span Rating: <i>Sheathing</i>	Bending Strength, F_b , S (lb-in./ft width)
	Strength Axis Either Parallel or Perpendicular to Supports
Regular 1/2"	55
Structural 1/2"	80
Structural 25/32"	97

EXAMPLE C3.2.1-1 Determine the Nominal Uniform Load Capacity in SDPWS Table 3.2.1

Determine the nominal uniform load capacity in *SDPWS* Table 3.2.1 Nominal Uniform Load Capacities (psf) for Wall Sheathing Resisting Out-of-Plane Wind Loads for the following conditions:

Sheathing type = wood structural panels
 Span rating or grade = 24/0
 Min. thickness = 3/8 in.
 Strength axis = perpendicular to supports
 Actual stud spacing = 12 in.

ASD (normal load duration, i.e., 10-yr) bending capacity:
 $F_b S = 250$ lb-in./ft width from Table C3.2A

ASD (normal load duration, i.e., 10-yr) shear capacity:
 $F_s I b/Q = 130$ lb/ft width from Table C3.2B

Maximum uniform load based on bending strength for a two-span condition:

$$w_b = \frac{96F_b S}{l^2} = \frac{96 \times 250}{12^2} = 167 \text{ psf}$$

Maximum uniform load based on shear strength for a two-span condition:

$$w_s = \frac{19.2F_s I b / Q}{l_{clearspan}} = \frac{19.2 \times 130}{(12 - 1.5)} = 238 \text{ psf}$$

Maximum uniform load based on bending governs. Converting to the nominal capacity basis of *SDPWS* Table 3.2.1:

$$w_{nominal} = \left(\frac{2.16}{\phi_b} \right) \times ASD_{10\text{-yr}} \quad \text{SDPWS Table 3.2.1}$$

$$= \frac{2.16}{0.85} \times 167 = 424 \text{ psf}$$

$$\approx 425 \text{ psf}$$

where:

2.16/0.85 = conversion from a normal load duration (i.e., 10-yr ASD basis) to the short-term (10-min) nominal capacity basis of *SDPWS* Table 3.2.1.



EXAMPLE C3.2.1-2 Determine the Nominal Uniform Load Capacity in SDPWS Table 3.2.1

Determine the nominal uniform load capacity in *SDPWS* Table 3.2.1 Nominal Uniform Load Capacities (psf) for Wall Sheathing Resisting Out-of-Plane Wind Loads for the following conditions:

Sheathing type = wood structural panels
 Span rating or grade = 40/20
 Min. thickness = 19/32 in.
 Strength axis = perpendicular to supports
 Actual stud spacing = 12 in.

ASD (normal load duration, i.e., 10-yr) bending capacity:
 $F_b S = 625 \text{ lb-in./ft width from Table C3.2A}$

ASD (normal load duration, i.e., 10-yr) shear capacity:
 $F_s I b/Q = 205 \text{ lb/ft width from Table C3.2B}$

Maximum uniform load based on bending strength for a two-span condition:

$$w_b = \frac{96F_b S}{l^2} = \frac{96 \times 625}{12^2} = 417 \text{ psf}$$

Maximum uniform load based on shear strength for a two-span condition:

$$w_s = \frac{19.2F_s I b / Q}{l_{clearspan}} = \frac{19.2 \times 205}{(12 - 1.5)} = 375 \text{ psf}$$

Maximum uniform load based on shear governs. Converting to the nominal capacity basis of *SDPWS* Table 3.2.1:

$$w_{nominal} = \left(\frac{2.16}{\phi_b} \right) \times ASD_{10-yr} \quad \text{SDPWS Table 3.2.1}$$

$$= \frac{2.16}{0.85} \times 375 = 953 \text{ psf}$$

$$\approx 955 \text{ psf}$$

where:

2.16/0.85 = conversion from a normal load duration (i.e., 10-yr ASD basis) to the short-term (10-min) nominal capacity basis of *SDPWS* Table 3.2.1.

C3.3 Connections

Section 3.3 refers the user to the *NDS* (6) when designing connections to resist wind or seismic forces. In many cases, resistance to out-of-plane forces due to wind may be limited by connection capacity (withdrawal capacity of the connection) rather than out-of-plane bending or shear capacity of the panel.

C4 LATERAL FORCE-RESISTING SYSTEMS

C4.1 General

C4.1.1 Design Requirements

General design requirements for lateral force-resisting systems are described in this section and are applicable to engineered structures.

C4.1.2 Shear Capacity

Nominal unit shear capacities (see C2.2) for wind and seismic require adjustment in accordance with *SDPWS* 4.2.3 for diaphragms and *SDPWS* 4.3.3 for shear walls to derive an appropriate design value.

C4.1.3 Deformation Requirements

Consideration of deformations (such as deformation of the overall structure, elements, connections, and systems within the structure) that can occur is necessary to maintain load path and ensure proper detailing. Special requirements are provided for wood members resisting forces from concrete and masonry (see C4.1.5) due to potentially large differences in stiffness and deflection limits for wood and concrete systems. Special requirements are also provided for open front buildings (see C4.2.5.1.1) where forces are distributed by diaphragm rotation.

C4.1.4 Boundary Elements

Boundary elements must be sized to transfer design tension and compression forces. Good construction practice and efficient design and detailing for boundary elements utilize framing members in the plane or tangent to the plane of the diaphragm or shear wall.

C4.1.5 Wood Members and Systems Resisting Seismic Forces Contributed by Masonry and Concrete Walls

The use of wood diaphragms with masonry or concrete walls is common practice. Story height and other limitations for wood members and wood systems resisting seismic forces from concrete or masonry walls are given to address deformation compatibility and are largely based on

field observations following major seismic events. Wood diaphragms and horizontal trusses are specifically permitted to resist horizontal seismic forces from masonry or concrete walls provided that the design of the diaphragm does not rely on torsional force distribution through the diaphragm. Primary considerations for this limitation are the flexibility of the wood diaphragm relative to masonry or concrete walls and the limited ability of masonry or concrete walls to tolerate out-of-plane wall displacements without failure.

The term “horizontal trusses” refers to trusses that are oriented such that their top and bottom chords and web members are in a horizontal or near horizontal plane. A horizontal truss transmits lateral loads to shear walls in a manner similar to a floor or roof diaphragm. In this context, a horizontal truss is a bracing system capable of resisting horizontal seismic forces contributed by masonry or concrete walls.

Where wood structural panel shear walls are used to provide resistance to seismic forces contributed by masonry and concrete walls, deflections are limited to 0.7% of the story height in accordance with deflection limits (5) for masonry and concrete construction. Strength level forces and appropriate deflection amplification factors, C_d , in accordance with *ASCE 7* should be used when calculating design story drift, Δ . The intent of the design story drift limit is to limit failure of the masonry or concrete portions of the structure due to excessive deflection. For example, inadequate diaphragm stiffness may lead to excessive out-of-plane deformation of the attached masonry or concrete wall.

C4.1.6 Wood Members and Systems Resisting Seismic Forces from Other Concrete or Masonry Construction

Seismic forces from other concrete or masonry construction (i.e. other than walls) are permitted and should be accounted for in design. *SDPWS* 4.1.6 is not intended to restrict the use of concrete floors – including wood floors with concrete toppings as well as reinforced concrete slabs – or similar such elements in floor construction. It is intended to clarify that, where such elements are pres-



ent in combination with a wood system, the wood system shall be designed to account for seismic forces generated by the additional mass of such elements.

Design of wood members to support the additional mass of concrete and masonry elements shall be in accordance with the *NDS* and required deflection limits as specified in concrete or masonry standards or model building codes (2). Masonry is defined as a built-up construction or combination of building units or materials of clay, shale, concrete, glass, gypsum, stone, or other approved units bonded together with or without mortar or grout or other accepted methods of joining.

C4.2 Wood Diaphragms

C4.2.1 Application Requirements

General requirements for wood diaphragms include consideration of diaphragm strength and deflection.

C4.2.2 Deflection

The total mid-span deflection of a blocked, uniformly nailed wood structural panel diaphragm can be calculated by summing the effects of four sources of deflection: framing bending deflection, panel shear deflection, deflection from nail slip, and deflection due to chord splice slip:

$$\delta_{dia} = \frac{\overset{\text{(bending, chord deformation excluding slip)}}{5vL^3}}{8EAW} + \frac{\overset{\text{(shear, panel deformation)}}{vL}}{4G_v t_v} + 0.188Le_n + \frac{\overset{\text{(shear, panel nail slip)}}{\sum (x\Delta_c)} \overset{\text{(bending, chord splice slip)}}{}}{2W} \quad (\text{C4.2.2-1})$$

where:

- v = induced unit shear, plf
- L = diaphragm dimension perpendicular to the direction of the applied force, ft
- E = modulus of elasticity of diaphragm chords, psi
- A = area of chord cross-section, in.²
- W = width of diaphragm in direction of applied force, ft
- G_vt_v = shear stiffness, lb/in. of panel depth. See Table C4.2.2A or C4.2.2B.
- x = distance from chord splice to nearest support, ft. For example, a shear wall aligned parallel to the loaded direction of the diaphragm would typically be considered a support.

C4.1.7 Toe-Nailed Connections

Limits on use of toe-nailed connections in seismic design categories D, E, and F for transfer of seismic forces is consistent with building code requirements (2). Test data (12) suggests that the toe-nailed connection limit on a bandjoist to wall plate connection may be too restrictive; however, an appropriate alternative limit requires further study. Where blocking is used to transfer high seismic forces, toe-nailed connections can sometimes split the block or provide a weakened plane for splitting.

Δ_c = diaphragm chord splice slip at the induced unit shear, in.

e_n = nail slip, in. See Table C4.2.2D.

Note: the 5/8 constant incorporates background derivations that cancel out the units of feet in the first term of the equation.

SDPWS Equation 4.2-1 is a simplification of Equation C4.2.2-1, using only three terms for calculation of the total mid-span diaphragm deflection:

$$\delta_{dia} = \frac{\overset{\text{(bending, chord deformation excluding slip)}}{5vL^3}}{8EAW} + \frac{\overset{\text{(shear, panel shear and nail slip)}}{0.25vL}}{1000G_a} + \frac{\overset{\text{(bending, chord splice slip)}}{\sum (x\Delta_c)}}{2W} \quad (\text{C4.2.2-2})$$

where:

- v = induced unit shear, plf
- L = diaphragm dimension perpendicular to the direction of the applied force, ft
- E = modulus of elasticity of diaphragm chords, psi
- A = area of chord cross-section, in.²
- W = width of diaphragm in direction of applied force, ft
- G_a = apparent diaphragm shear stiffness, kips/in.
- x = distance from chord splice to nearest support, ft
- Δ_c = diaphragm chord splice slip at the induced unit shear, in.

Distribution of shear forces among shear panels in a diaphragm is a function of the layup and nailing pattern of panels to framing. For this reason, shear deflection in a wood diaphragm is related to panel shear, panel layout, nailing pattern, and nail load-slip relationship. In Equation C4.2.2-2, panel shear and nail slip are assumed to be inter-related and have been combined into a single term to account for shear deformations. Equation C4.2.2-3 equates apparent shear stiffness, G_a , to nail slip and panel shear stiffness terms used in the four-term equation:

$$G_a = \frac{1.4v_{s(ASD)}}{\frac{1.4v_{s(ASD)}}{G_v t_v} + 0.75e_n} \quad (C4.2.2-3)$$

where:

1.4 $v_{s(ASD)}$ = 1.4 times the ASD unit shear capacity for seismic. The value of 1.4 converts ASD level forces to strength level forces.

Calculated deflection, using either the 4-term (Equation C4.2.2-1) or 3-term equation (*SDPWS* Equation 4.2-1), is identical at the critical strength design level — 1.4 times the allowable shear value for seismic (see Figure C4.3.2).

For unblocked wood structural panel diaphragms, tabulated values of G_a are based on limited test data for blocked and unblocked diaphragms (3, 4, and 11). For diaphragms of Case 1, reduced shear stiffness equal to 0.6 G_a

Table C4.2.2A Shear Stiffness, $G_v t_v$ (lb/in. of depth), for Wood Structural Panels

Span Rating ⁴	Minimum Nominal Panel Thickness (in.)	Structural Sheathing				Structural I			
		Plywood			OSB	Plywood			OSB
		3-ply	4-ply	5-ply ³		3-ply	4-ply	5-ply ³	
Sheathing Grades¹									
24/0	3/8 ²	25,000	32,500	37,500	77,500	32,500	42,500	41,500	77,500
24/16	7/16	27,000	35,000	40,500	83,500	35,000	45,500	44,500	83,500
32/16	15/32	27,000	35,000	40,500	83,500	35,000	45,500	44,500	83,500
40/20	19/32	28,500	37,000	43,000	88,500	37,000	48,000	47,500	88,500
48/24	23/32	31,000	40,500	46,500	96,000	40,500	52,500	51,000	96,000
Single Floor Grades									
16 oc	19/32	27,000	35,000	40,500	83,500	35,000	45,500	44,500	83,500
20 oc	19/32	28,000	36,500	42,000	87,000	36,500	47,500	46,000	87,000
24 oc	23/32	30,000	39,000	45,000	93,000	39,000	50,500	49,500	93,000
32 oc	7/8	36,000	47,000	54,000	110,000	47,000	61,000	59,500	110,000
48 oc	1-1/8	50,500	65,500	76,000	155,000	65,500	85,000	83,500	155,000

1. Sheathing grades used for calculating G_a values for diaphragm and shear wall tables.
2. $G_v t_v$ values for 3/8" panels with span rating of 24/0 used to estimate G_a values for 5/16" panels.
3. 5-ply applies to plywood with five or more layers. For 5-ply plywood with three layers, use $G_v t_v$ values for 4-ply panels.
4. See Table 4.2.2C for relationship between span rating and nominal panel thickness.

Table C4.2.2B Shear Stiffness, $G_v t_v$ (lb/in. of depth), for Other Sheathing Materials

Sheathing Material	Minimum Nominal Panel Thickness (in.)	$G_v t_v$
Plywood Siding	5/16 & 3/8	25,000
	3/8	25,000
Particleboard	1/2	28,000
	5/8	28,500
Structural Fiberboard	1/2 & 25/32	25,000
Gypsum board	1/2 & 5/8	40,000
Lumber	All	25,000

EXAMPLE C4.2.2-1 Derive G_a in SDPWS Table 4.2A

Derive G_a in <i>SDPWS</i> Table 4.2A for a blocked wood structural panel diaphragm constructed as follows:	Panel shear stiffness: $G_v t_v = 77,500$ lb/in. of panel depth Table C4.2.2A
Sheathing grade = Structural I (OSB)	Nail load/slip at $1.4 v_{s(ASD)}$: $V_n =$ fastener load (lb/nail) $= 1.4 v_{s(ASD)} (6 \text{ in.}) / (12 \text{ in.})$ $= 129.5$ lb/nail
Sheathing layup = Case 1	$e_n = (V_n / 456)^{3.144}$ Table C4.2.2D $= (129.5 / 456)^{3.144} = 0.0191$ in.
Nail size = 6d common (0.113" diameter, 2" length)	
Minimum nominal panel thickness = 5/16 in.	
Boundary and panel edge nail spacing = 6 in.	Calculate G_a:
Minimum width of nailed face = 2x nominal	$G_a = \frac{1.4 v_{s(ASD)}}{\frac{1.4 v_{s(ASD)}}{G_v t_v} + 0.75 e_n} \quad (C4.2.2-3)$
Nominal unit shear capacity for seismic, $v_s = 370$ plf <i>SDPWS</i> Table 4.2A	$G_a = 14,660$ lb/in. ≈ 15 kips/in. <i>SDPWS</i> Table 4.2A
Allowable unit shear capacity for seismic: $v_{s(ASD)} = 370 \text{ plf} / 2 = 185$ plf	

EXAMPLE C4.2.2-2 Derive G_a in SDPWS Table 4.2B

Derive G_a in <i>SDPWS</i> Table 4.2B for an unblocked wood structural panel diaphragm constructed as follows:	$G_a = 15$ kips/in. <i>SDPWS</i> Table 4.2A
Sheathing grade = Structural I (OSB)	Case 1 - unblocked $G_a = 0.6 G_a$ (blocked) $= 0.6 (15.0) = 9.0$ kips/in. <i>SDPWS</i> Table 4.2B
Nail size = 6d common (0.113" diameter, 2" length)	Cases 2, 3, 4, 5, and 6 - unblocked $G_a = 0.4 G_a$ (blocked) $= 0.4 (15.0) = 6.0$ kips/in. <i>SDPWS</i> Table 4.2B
Minimum nominal panel thickness = 5/16 in.	
Minimum width of nailed face = 2x nominal	
Boundary and panel edge nail spacing = 6 in.	

was used to derive tabulated G_a values. For unblocked diaphragms of Case 2, 3, 4, 5, and 6, reduced shear stiffness equal to $0.4G_a$ was used to derive tabulated G_a values. Examples C4.2.2-1 and C4.2.2-2 show derivations of G_a in *SDPWS* Tables 4.2A and 4.2B, respectively.

In diaphragm table footnotes, a factor of 0.5 is provided in the diaphragm table footnotes to adjust tabulated G_a values (based on fabricated dry condition) to approximate G_a where "green" framing is used. This factor is based on analysis of apparent shear stiffness for wood structural panel shear wall and diaphragm construction where:

- 1) framing moisture content is greater than 19% at time of fabrication (green); and,

- 2) framing moisture content is less than or equal to 19% at time of fabrication (dry).

The average ratio of "green" to "dry" for G_a across shear wall and diaphragm cells ranged from approximately 0.52 to 0.55. A rounded value of 0.5 results in slightly greater values of calculated deflection for "green" framing when compared to the more detailed 4-term deflection equations. Although based on nail slip relationships applicable to wood structural panel shear walls, this reduction can also be extended to lumber sheathed diaphragm construction.

Comparison with Diaphragm Test Data

Tests of blocked and unblocked diaphragms (4) are compared in Table C4.2.2E for diaphragms constructed as follows:

- Sheathing material = Sheathing Grade, 3/8" minimum nominal panel thickness
- Nail size = 8d common (0.131" diameter, 2½" length)
- Diaphragm length, L = 24 ft
- Diaphragm width, W = 24 ft
- Panel edge nail spacing = 6 in.
- Boundary nail spacing = 6 in. o.c. at boundary parallel to load (4 in. o.c. at boundary perpendicular to load for walls A and B)

Calculated deflections at $1.4 \times v_{s(ASD)}$ closely match test data for blocked and unblocked diaphragms.

In Table C4.2.2F, calculated deflections using *SDPWS* Equation 4.2-1 are compared to deflections from two tests of 20 ft x 60 ft (W = 20 ft, L = 60 ft) diaphragms (26) at 1.4 times the allowable seismic design value for a horizontally sheathed and single diagonally sheathed lumber diaphragm. Calculated deflections include estimates of deflection due to bending, shear, and chord slip. For both diaphragms, calculated shear deformation accounted for nearly 85% of the total calculated mid-span deflection. Tested deflection for Diaphragm 4 is slightly greater than estimated by calculation and may be attributed to limited effectiveness of the diaphragm chord construction which

Table C4.2.2C Relationship Between Span Rating and Nominal Thickness

Span Rating	Nominal Thickness (in.)											
	3/8	7/16	15/32	1/2	19/32	5/8	23/32	3/4	7/8	1	1-1/8	
Sheathing												
24/0	P	A	A	A								
24/16		P	A	A								
32/16			P	A	A	A						
40/20					P	A	A	A				
48/24							P	A	A			
Single Floor Grade												
16 oc					P	A						
20 oc					P	A						
24 oc							P	A				
32 oc									P	A		
48 oc												P

P = Predominant nominal thickness for each span rating.

A = Alternative nominal thickness that may be available for each span rating. Check with suppliers regarding availability.

Table C4.2.2D Fastener Slip, e_n (in.)

Sheathing	Fastener Size	Maximum Fastener Load (V_n) (lb/fastener)	Fastener Slip, e_n (in.)	
			Fabricated w/green (>19% m.c.) lumber	Fabricated w/dry (\leq 19% m.c.) lumber
Wood Structural Panel (WSP) or Particleboard ¹	6d common	180	$(V_n/434)^{2.314}$	$(V_n/456)^{3.144}$
	8d common	220	$(V_n/857)^{1.869}$	$(V_n/616)^{3.018}$
	10d common	260	$(V_n/977)^{1.894}$	$(V_n/769)^{3.276}$
Structural Fiberboard	All	-	-	0.07
Gypsum Board	All	-	-	0.03
Lumber	All	-	-	0.07

1. Slip values are based on plywood and OSB fastened to lumber with a specific gravity of 0.50 or greater. The slip shall be increased by 20 percent when plywood is not Structural I. Nail slip for common nails have been extended to galvanized box or galvanized casing nails of equivalent penny weight for purposes of calculating G_a .



utilized blocking to transfer forces to the double 2x6 top plate chord. For Diaphragm 2, chord construction utilized 2-2x10 band joists.

C4.2.3 Unit Shear Capacities

ASD and LRFD unit shear capacities for wind and seismic are calculated as follows from nominal values for wind, v_w , and seismic, v_s .

ASD unit shear capacity for wind, $v_{w(ASD)}$:

$$v_{w(ASD)} = \frac{v_w}{2.0} \quad (C4.2.3-1)$$

ASD unit shear capacity for seismic, $v_{s(ASD)}$:

$$v_{s(ASD)} = \frac{v_s}{2.0} \quad (C4.2.3-2)$$

where:

2.0 = ASD reduction factor

LRFD unit shear capacity for wind, $v_{w(LRFD)}$:

$$v_{w(LRFD)} = 0.8v_w \quad (C4.2.3-3)$$

LRFD unit shear capacity for seismic, $v_{s(LRFD)}$:

$$v_{s(LRFD)} = 0.8v_s \quad (C4.2.3-4)$$

where:

0.8 = resistance factor, ϕ_D , for shear walls and diaphragms

Table C4.2.2E Data Summary for Blocked and Unblocked Wood Structural Panel Diaphragms

Wall	Blocked/ Unblocked	$1.4v_{s(ASD)}$ (plf)	Actual Deflection, (in.)	Apparent Stiffness ¹ , G_a , (kips/in.)	Calculated Deflection, (in.)	Diaphragm Layout
A	Blocked	378	0.22	14.4	0.18	Case 1
D	Unblocked	336	0.26	(0.60 x 14.4) = 8.6	0.26	Case 1
B	Blocked	378	0.15	14.4	0.18	Case 3
E	Unblocked	252	0.23	(0.40 x 14.4) = 5.8	0.29	Case 3

1. Values of G_a for the blocked diaphragm case were taken from SDPWS Table 4.2A and multiplied by 1.2 (see footnote 3) because sheathing material was assumed to be comparable to 4/5-ply construction.

Table C4.2.2F Data Summary for Horizontal Lumber and Diagonal Lumber Sheathed Diaphragms

Diaphragm	Description	Calculated			Actual
		$1.4v_{s(ASD)}$ (plf)	G_a (kips/in.)	δ^1 (in.)	δ (in.)
Diaphragm 4	Horizontal Lumber Sheathing – Dry Lumber Sheathing – 2 x 6 chord (double top plates), 5 splices	70	1.5	0.81	0.93
Diaphragm 2	Diagonal Lumber Sheathing – Green Lumber Sheathing – 2 x 10 chord, 3 splices – Exposed outdoors for 1 month	420	6.0	1.23	1.05

1. Calculated deflection equal to 0.81" includes estimates of deflection due to bending, shear, and chord slip (0.036" + 0.7" + 0.07" = 0.81"). Calculated deflection equal to 1.23" includes estimates of deflection due to bending, shear, and chord slip (0.13" + 1.05" + 0.05" = 1.23").

EXAMPLE C4.2.2-3 Calculate Mid-Span Diaphragm Deflection

Figure C4.2.2-3a Diaphragm Dimensions and Shear and Moment Diagram

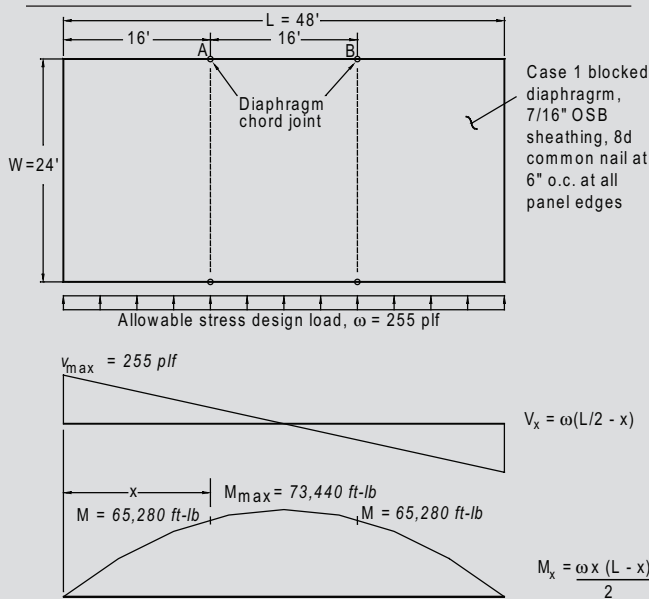

Calculate mid-span deflection for the blocked wood structural panel diaphragm shown in Figure C4.2.2-3a. The diaphragm chord splice is sized using allowable stress design loads from seismic while deflection due to seismic is based on strength design loads in accordance with ASCE 7.

Diaphragm apparent shear stiffness, G_a :

$$G_a = 14 \text{ kips/in.} \quad (\text{SDPWS Table 4.2A})$$

Diaphragm allowable unit shear capacity for seismic, $V_s(ASD)$:

$$V_s(ASD) = 255 \text{ plf} \quad (\text{SDPWS Table 4.2A})$$

Diaphragm chord:

Two 2x6 No. 2 Douglas Fir-Larch, $E = 1,600,000$ psi, and $G = 0.50$

Part 1 - Calculate the number of 16d common nails in the chord splice

For each chord, one top plate is designed to resist induced axial force (tension or compression) while the second top plate is designed as a splice plate (see Figure C4.2.2-3b). The connection at the chord splice consists of 16d common nails (0.162" diameter x 3-1/2" length).

The allowable design value for a single 16d common nail in a face-nailed connection is: $Z'_{ASD} = 226 \text{ lb}$.

The axial force (T or C) at each joint:

$$(T \text{ or } C) = \frac{M_x}{W} = \frac{65,280 \text{ ft-lb}}{24 \text{ ft}} = 2,720 \text{ lb}$$

The number of 16d common nails, n , is:

$$n = \frac{2,720 \text{ lb}}{226 \text{ lb/nail}} = 12 \text{ nails}$$

Use twelve 16d common nails on each side of joint A and joint B to transfer chord axial forces. Designers should consider whether a single maximum chord force at mid-span of the diaphragm should be used to determine the number of fasteners in each splice joint since the actual location of joints may not be known. The number of 16d common nails based on the maximum chord force at mid-span of the diaphragm is:

$$n = \frac{73,440 \text{ ft-lb} / 24 \text{ ft}}{226 \text{ lb/nail}} = 14 \text{ nails}$$

Figure C4.2.2-3b Diaphragm Chord, Double Top Plate with Two Joints in Upper Plate

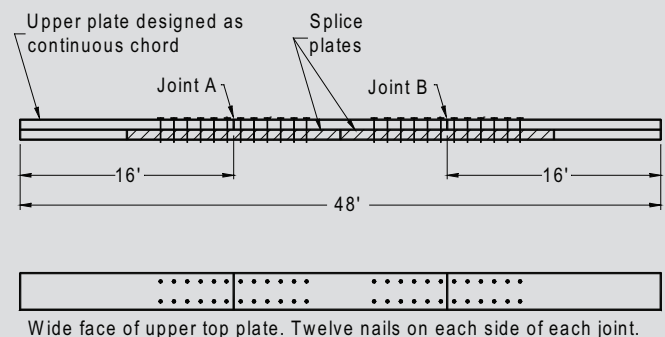

Part 2 - Calculated mid-span deflection

ASCE 7 requires that seismic story drift be determined using strength level design loads; therefore, induced unit shears and chord forces used in terms 1, 2, and 3 of the deflection equation are calculated using strength level

(continued)

EXAMPLE C4.2.2-3 Calculate Mid-Span Diaphragm Deflection (continued)

design loads. Strength level design loads can be estimated by multiplying the allowable stress design seismic loads, shown in Figure C4.2.2-3a, by 1.4.

A spliced chord member has an “effective” stiffness (EA) due to the splice slip that occurs throughout the chord. In this example, and for typical applications of Equation C4.2.2-2, the effect of the spliced chord on mid-span deflection is addressed by independently considering deflection from: a) chord deformation due to elongation or shortening assuming a continuous chord member per deflection equation Term 1, and b) deformations due to chord splice slip at chord joints per deflection equation Term 3.

Diaphragm deflection is calculated in accordance with the following:

$$\delta_{dia} = \frac{5vL^3}{8EAW} + \frac{0.25vL}{1000G_a} + \frac{\sum(x\Delta_c)}{2W} \quad (SDPWS C4.2.2-2)$$

Term 1. Deflection due to bending and chord deformation (excluding chord splice slip):

$$\begin{aligned} \delta_{dia(bending, chords)} &= \frac{5vL^3}{8EAW} \\ &= \frac{5(1.4 \times 255 \text{ plf})(48 \text{ ft})^3}{8(1,600,000 \text{ psi})(8.25 \text{ in.}^2)(24 \text{ ft})} \\ &= 0.078 \text{ in.} \end{aligned}$$

where:

- $v = 1.4 \times 255 \text{ plf}$, induced unit shear due to strength level seismic load
- $L = 48 \text{ ft}$, diaphragm length
- $W = 24 \text{ ft}$, diaphragm width
- $E = 1,600,000 \text{ psi}$, modulus of elasticity of the 2x6 chord member ignoring effects of chord splice slip. The effect of chord splice slip on chord deformation is addressed in deflection equation Term 3.
- $A = 8.25 \text{ in.}^2$, cross sectional area of one 2x6 top plate designed to resist axial forces.

The second top plate is designed as a splice plate.

Term 2. Deflection due to shear, panel shear, and nail slip:

$$\begin{aligned} \delta_{dia(panel\ shear+nail\ slip)} &= \frac{0.25vL}{1000G_a} \\ &= \frac{0.25(1.4 \times 255 \text{ plf})(48 \text{ ft})}{1000(14 \text{ kips/in.})} \\ &= 0.306 \text{ in.} \end{aligned}$$

where:

$$G_a = 14 \text{ kips/in.}, \text{ apparent shear stiffness} \quad (SDPWS \text{ Table } 4.2A)$$

Term 3. Deflection due to bending and chord splice slip:

$$\delta_{dia(chord\ splice\ slip)} = \frac{\sum(x\Delta_c)}{2W}$$

where:

- $x = 16 \text{ ft}$, distance from the joint to the nearest support (see Figure C4.2.2-3a). Each joint is located 16 ft from the nearest support.
- $\Delta_c = \text{Joint deformation (in.) due to chord splice slip in each joint. The chord force, } T \text{ or } C, \text{ at each joint is:}$

$$(T \text{ or } C) = \frac{(1.4 \times 65,280 \text{ ft-lb})}{24 \text{ ft}} = 3,808 \text{ lb}$$

The slip, Δ , associated with each joint:

$$\begin{aligned} \Delta_c &= \frac{2(T \text{ or } C)}{\gamma n} \\ &= \frac{2(3,808 \text{ lb})}{11,737 \text{ lb/in.} / \text{nail} (12 \text{ nails})} \\ &= 0.054 \text{ in.} \end{aligned}$$

(continued)

EXAMPLE C4.2.2-3 Calculate Mid-Span Diaphragm Deflection (continued)**where:**

$\gamma = 11,737 \text{ lb/in./nail}$, load slip modulus for dowel type fasteners determined in accordance with *National Design Specification for Wood Construction* (NDS) Section 10.3.6, $\gamma = 180,000 \text{ D}^{1.5}$.

(Note: A constant of 2 is used in the numerator to account for slip in nailed splices on each side of the joint.)

Deflection due to tension chord splice slip is:

$$\delta_{dia(\text{tension chord splice slip})} = \frac{\sum (16 \text{ ft} \times 0.054 \text{ in.}) + (16 \text{ ft} \times 0.054 \text{ in.})}{2(24 \text{ ft})} = 0.036 \text{ in.}$$

Assuming butt joints in the compression chord are not tight and have a gap that exceeds the splice slip, the tension chord slip calculation is also applicable to the compression chord:

$$\delta_{dia(\text{compression chord splice slip})} = 0.036 \text{ in.}$$

Total deflection due to chord splice slip is:

$$\delta_{dia(\text{chord splice slip})} = 0.036 \text{ in.} + 0.036 \text{ in.} = 0.072 \text{ in.}$$

Total mid-span deflection:

Summing deflection components from deflection equation Term 1, Term 2, and Term 3 results in the following total diaphragm mid-span deflection:

$$\delta_{dia} = 0.078 \text{ in.} + 0.306 \text{ in.} + 0.072 \text{ in.} = 0.456 \text{ in.}$$

C4.2.4 Diaphragm Aspect Ratios

Maximum aspect ratios for floor and roof diaphragms (*SDPWS* Table 4.2.4) using wood structural panel or diagonal board sheathing are based on building code requirements (See *SDPWS* 4.2.5.1 for aspect ratio limits for cases where a torsional irregularity exists, for open front buildings, and cantilevered diaphragms).

C4.2.5 Horizontal Distribution of Shear

General seismic design requirements (5) define conditions applicable for the assumption of flexible diaphragms. For flexible diaphragms, loads are distributed to wall lines according to tributary area whereas for rigid diaphragms, loads are distributed according to relative stiffness of shear walls.

The actual distribution of seismic forces to vertical elements (shear walls) of the seismic-force-resisting system is dependent on: 1) the stiffness of vertical elements relative to horizontal elements, and 2) the relative stiffness of various vertical elements.

Where a series of vertical elements of the seismic-force-resisting system are aligned in a row, seismic forces will distribute to the different elements according to their relative stiffness.

C4.2.5.1 Torsional Irregularity: Excessive torsional response of a structure can be a potential cause of failure. As a result, diaphragm dimension and diaphragm aspect ratio limitations are provided for different building configurations. The test for torsional irregularity is consistent with general seismic design requirements (5).

C4.2.5.1.1 Open Front Structures: A structure with shear walls on three sides only (open front) is one category of structure that requires transfer of forces through diaphragm rotation. Assuming rigid diaphragms, shear force is transferred to shear wall(s) parallel to the applied force and torsional moment due to eccentric loading is transferred into perpendicular walls. Applicable limitations are provided in *SDPWS* 4.2.5.1.1. Design considerations include *SDPWS* prescriptive limitations on diaphragm length and diaphragm aspect ratio to limit transfer of forces through diaphragm rotation, and requirements of general seismic design criteria (5) including drift limits, increased forces due to presence



of irregularities, and increased forces in accordance with redundancy provisions.

C4.2.5.2 Cantilevered Diaphragms: Limitations on cantilever distance and diaphragm aspect ratios for diaphragms that cantilever horizontally past the outermost shear wall (or other vertical lateral force resisting element) are in addition to requirements of general seismic design criteria (5), including drift limits, increased forces due to presence of irregularities, and increased forces in accordance with redundancy provisions.

C4.2.6 Construction Requirements

C4.2.6.1 Framing Requirements: The transfer of forces into and out of diaphragms is required for a continuous load path. Boundary elements must be sized and connected to the diaphragm to ensure force transfer. This section provides basic framing requirements for boundary elements in diaphragms. Good construction practice and efficient design and detailing for boundary elements utilizes framing members in the plane of the diaphragm or tangent to the plane of the diaphragm (See C4.1.4). Where splices occur in boundary elements, transfer of force between boundary elements should be through the addition of framing members or metal connectors. The use of diaphragm sheathing to splice boundary elements is not permitted.

C4.2.6.2 Sheathing: Sheathing types for diaphragms included in *SDPWS* Table 4.2A and Table 4.2B are categorized in terms of the following structural use panel grades: Structural I, Sheathing, and Single-Floor. Sheathing grades rated for subfloor, roof, and wall use are usually unsanded and are manufactured with exterior glue. The Structural I sheathing grade is used where the greatest available shear and cross-panel strength properties are required. Structural I is made with exterior glue only. The Single-Floor sheathing grade is rated for use as a combination of subfloor and underlayment, usually with tongue and groove edges, and has sanded or touch sanded faces.

SDPWS Table 4.2A and Table 4.2B are applicable to both oriented strand board (OSB) and plywood. While strength properties between equivalent grades and thickness of OSB and plywood are the same, shear stiffness of OSB is greater than that of plywood of equivalent grade and thickness.

Tabulated plywood G_a values are based on 3-ply plywood. Separate values of G_a for 4-ply, 5-ply, and composite panels were calculated and ratios of these values to G_a based on 3-ply were shown to be in the order of 1.09 to 1.22 for shear walls and 1.04 to 1.16 for diaphragms. A single G_a multiplier of 1.2 was chosen for 4-ply, 5-ply, and composite panels in table footnotes. This option was considered preferable to tabulating G_a values for 3-ply,

4-ply, 5-ply, and composite panels separately.

C4.2.6.3 Fasteners: Adhesive attachment in diaphragms can only be used in combination with fasteners. Details on type, size, and spacing of mechanical fasteners used for typical floor, roof, and ceiling diaphragm assemblies are provided in Tables 4.2A, 4.2B, and 4.2C and in *SDPWS* 4.2.7 Diaphragm Assemblies.

C4.2.7 Diaphragm Assemblies

C4.2.7.1 Wood Structural Panel Diaphragms: Where wood structural panel sheathing is applied to solid lumber planking or laminated decking – such as in a retrofit or new construction where wood structural panel diaphragm capacities are desired – additional fastening, aspect ratio limits, and other requirements are prescribed to develop diaphragm capacity and transfer forces to boundary elements.

C4.2.7.1.1 Blocked Diaphragms: Standard construction of wood structural panel diaphragms requires use of full size sheets, not less than 4'x8' except at changes in framing where smaller pieces may be needed to cover the roof or floor. Panel edges must be supported by and fastened to framing members or blocking. The 24" width limit coincides with the minimum width where panel strength capacities for bending and axial tension are applicable (6). For widths less than 24", capacities for bending and axial tension should be reduced in accordance with applicable panel size adjustment factors (panel width adjustment factors are described in the Commentary to the *National Design Specification for Wood Construction* (6)). Apparent shear stiffness values provided in *SDPWS* Table 4.2A are based on standard assumptions for panel shear stiffness for oriented strand board (OSB), plywood, and nail load slip (see C4.2.2).

In accordance with *SDPWS* Table 4.2A, nail spacing requirements for a given unit shear capacity vary by panel lay-out, framing orientation, and load direction and are grouped into six unique cases as shown in *SDPWS* Table 4.2A. An alternative presentation which clarifies influence of load direction on determination of applicable case is provided in Figure C4.2.7.1.1.

C4.2.7.1.1(3): For closely spaced or larger diameter nails, staggered nail placement at each panel edge is intended to prevent splitting in the framing member (see Figure C4.2.7.1.1(3)).

C4.2.7.1.2 High Load Blocked Diaphragms: Provisions for wood structural panel blocked diaphragms with multiple rows of fasteners, also known as "high load diaphragms" are consistent with provisions in the *2006 International Building Code (IBC)* and the *2003 National Earthquake Hazard Reduction Program (NEHRP) Provisions*. Tests of nailed plywood-lumber joints (32)

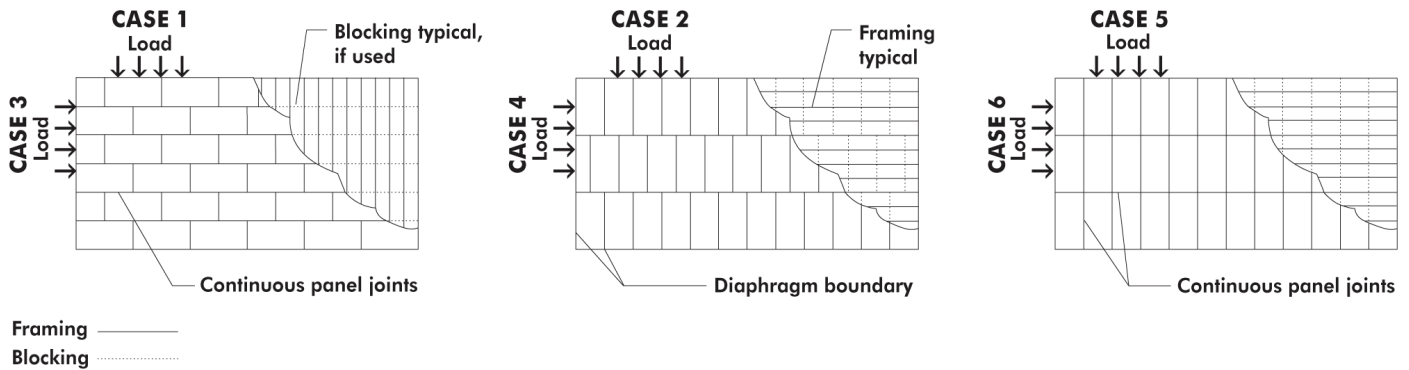
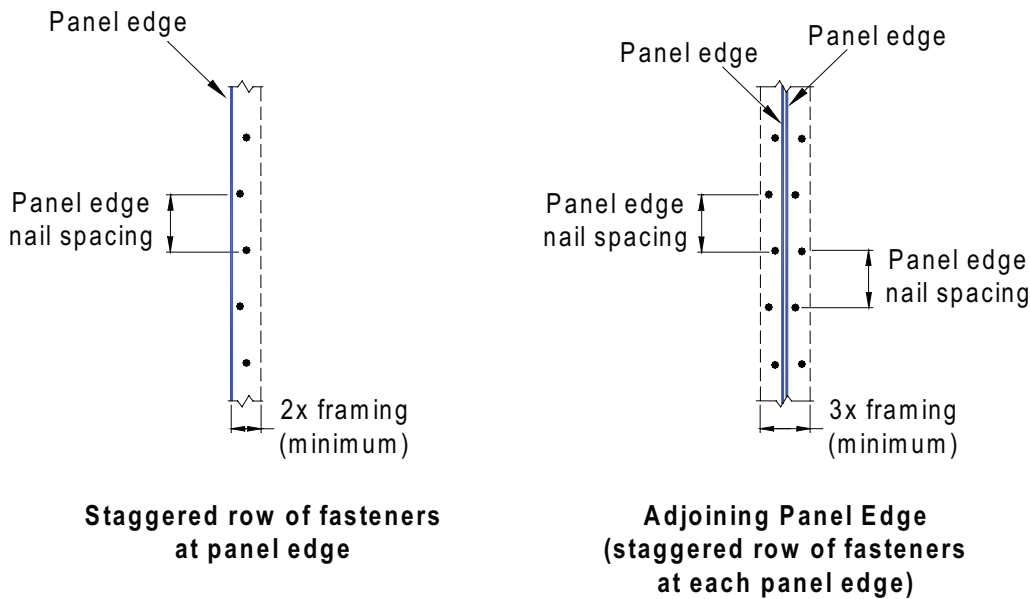
Figure C4.2.7.1.1 Diaphragm Cases 1 through 6**Figure C4.2.7.1.1(3) Staggering of Nails at Panel Edges of Blocked Diaphragms**

closely match recommended nailing patterns and verify calculations of unit shear associated with multiple rows of 10d common wire nails in Table 4.2B. The high load diaphragm table specifies use of framing with a 3x or 4x minimum nominal width of nailed face at adjoining panel edges and boundaries and the presence of multiple rows of 10d common wire nails at these locations (see *SDPWS* Figure 4C). Fastener spacing per line is listed in Table 4.2B as well as number of lines of fasteners. Nails should not be located closer than $3/8$ " from panel edges. Where the nominal width of nailed face and nail schedule permits greater panel edge distance, a $1/2$ " minimum distance from adjoining panel edges is specified. Apparent shear stiffness values are tabulated for each combination of nailing and sheathing thickness consistent with the format of tabulat-

ing apparent shear stiffness, G_a , for typical blocked and unblocked diaphragms.

SDPWS Figure 4C depicts a $1/8$ " minimum gap between adjoining panel edges to allow for dimensional change of the panel. In general, 4'x8' panels will increase slightly in dimension due to increased moisture content in-use relative to moisture content immediately following manufacture. In some cases, due to exposure conditions following manufacture, the expected increase in panel dimensions is smaller than anticipated by the $1/8$ " minimum gap and therefore the gap at time of installation may be less than $1/8$ " minimum. Dimensional change and recommendations for installation can vary by product and manufacturer, therefore recommendations of the manufacturer for the specific product should be followed.

C4.2.7.1.3 Unblocked Diaphragms: Standard construction of unblocked wood structural panel diaphragms requires use of full size sheets, not less than 4'x8' except at changes in framing where smaller sections may be needed to cover the roof or floor. Unblocked panel widths are limited to 24" or wider. Where smaller widths are used, panel edges must be supported by and fastened to framing members or blocking. The 24" width limit coincides with the minimum width where panel strength capacities for bending and axial tension are applicable (6). For widths less than 24", capacities for bending and axial tension should be reduced in accordance with applicable panel size adjustment factors (panel width adjustment factors are described in the Commentary to the *National Design Specification for Wood Construction* (6)). Apparent shear stiffness values provided in *SDPWS* Table 4.2C are based on standard assumptions for panel shear stiffness for oriented strand board (OSB), plywood, and nail load slip (see C4.2.2).

C4.2.7.2 Diaphragms Diagonally Sheathed with Single Layer of Lumber: Single diagonally sheathed lumber diaphragms have comparable strength and stiffness to many

wood structural panel diaphragm systems. Apparent shear stiffness in *SDPWS* Table 4.2D is based on assumptions of relative stiffness and nail slip (see C4.2.2).

C4.2.7.3 Diaphragms Diagonally Sheathed with Double-Layer of Lumber: Double diagonally sheathed lumber diaphragms have comparable strength and stiffness to many wood structural panel diaphragm systems. Apparent shear stiffness in *SDPWS* Table 4.2D is based on assumptions of relative stiffness and nail slip (see C4.2.2).

C4.2.7.4 Diaphragms Horizontally Sheathed with Single-Layer of Lumber: Horizontally sheathed lumber diaphragms have low strength and stiffness when compared to those provided by wood structural panel diaphragms and diagonally sheathed lumber diaphragms of the same overall dimensions. In new and existing construction, added strength and stiffness can be developed through attachment of wood structural panels over horizontally sheathed lumber diaphragms (see *SDPWS* 4.2.7.1). Apparent shear stiffness in *SDPWS* Table 4.2D is based on assumptions of relative stiffness and nail slip (see C4.2.2).

C4.3 Wood Shear Walls

C4.3.1 Application Requirements

General requirements for wood shear walls include consideration of shear wall deflection (discussed in 4.3.2) and strength (discussed in 4.3.3).

Shear wall performance has been evaluated by monotonic and cyclic testing and references to test reports are provided throughout the Commentary. Cyclic testing in accordance with ASTM E 2126 (34) Method C is commonly used to study seismic performance of wood frame shear wall behavior (14, 22, 25, 29, and 33). The cyclic loading protocol associated with ASTM E 2126 Method C is also known as the "CUREE" protocol (37). Reports containing results (15, 28, and 36) from other cyclic protocol, such as ASTM E 2126 Method A and Method B, commonly referred to as the "SEAoSC" and "ISO" protocols respectively, are also included as references for seismic design provisions of the *SDPWS*.

C4.3.2 Deflection

The deflection of a shear wall can be calculated by summing the effects of four sources of deflection: framing bending deflection, panel shear deflection, deflection from nail slip, and deflection due to wall anchorage slip:

$$\delta_{sw} = \frac{8vh^3}{EAb} + \frac{vh}{G_v t_v} + 0.75he_n + \frac{h}{b}\Delta_a \quad (\text{C4.3.2-1})$$

where:

v = induced unit shear, plf

h = shear wall height, ft

E = modulus of elasticity of end posts, psi

A = area of end posts cross-section, in.²

b = shear wall length, ft

$G_v t_v$ = shear stiffness, lb/in. of panel depth. See Table C4.2.2A or C4.2.2B.

Δ_a = total vertical elongation of wall anchorage system (including fastener slip, device elongation, rod elongation, etc.) at the induced unit shear in the shear wall, in.

e_n = nail slip, in. See Table C4.2.2D.

Note: the constant 8 in the first term and the constant 0.75 in the third term incorporate background derivations that cancel out the units of feet in each term.

SDPWS Equation 4.3-1 is a simplification of Equation C4.3.2-1, using only three terms for calculation of shear wall deflection:

$$\delta_{sw} = \frac{8vh^3}{EAb} + \frac{vh}{1000G_a} + \frac{h}{b}\Delta_a \quad (\text{C4.3.2-2})$$

where:

- v = induced unit shear, plf
- h = shear wall height, ft
- E = modulus of elasticity of end posts, psi
- A = area of end post cross-section, in.²
- b = shear wall length, ft
- G_a = apparent shear wall shear stiffness, kips/in.
- Δ_a = total vertical elongation of wall anchorage system (including fastener slip, device elongation, rod elongation, etc.) at the induced unit shear in the shear wall, in.

In *SDPWS* Equation 4.3-1, deflection due to panel shear and nail slip are accounted for by a single apparent shear stiffness term, G_a . Calculated deflection, using either the 4-term (Equation C4.3.2-1) or 3-term equation (*SDPWS* Equation 4.3-1), are identical at 1.4 times the allowable shear value for seismic (see Figure C4.3.2). Small “absolute” differences in calculated deflection - below 1.4 times the allowable shear value for seismic - are generally negligible for design purposes. These small differences, however, can influence load distribution assumptions based on relative stiffness if both deflection calculation methods are used in a design. For consistency and to minimize calculation-based differences, either the 4-term equation or 3-term equation should be used.

Each term of the 3-term deflection equation accounts for independent deflection components that contribute to overall shear wall deflection. For example, apparent shear stiffness is intended to represent only the shear component of deflection and does not also attempt to account for bending or wall anchorage slip. In many cases, such as for gypsum wallboard shear walls and fiberboard shear walls, results from prior testing (17 and 23) used to verify apparent shear stiffness estimates were based on ASTM E 72 (41) where effect of bending and wall anchorage slip are minimized due to the presence of metal tie-down rods in the standard test set-up. The relative contribution of each of the deflection components will vary by aspect

ratio of the shear wall. For other than narrow shear walls, deformation due to shear deformation (combined effect of nail slip and panel shear deformation) is the largest component of overall shear wall deflection.

Effect of wall anchorage slip becomes more significant as the aspect ratio increases. The *SDPWS* requires an anchoring device (see *SDPWS* 4.3.6.4.2) at each end of the shear wall where dead load stabilizing moment is not sufficient to prevent uplift due to overturning. For standard anchoring devices (tie-downs), manufacturers’ literature typically includes ASD capacity (based on short-term load duration for wind and seismic), and corresponding deflection of the device at ASD levels. Deflection of the device at strength level forces may also be obtained from manufacturers’ literature. Reported deflection may or may not include total deflection of the device relative to the wood post and elongation of the tie-down bolt in tension. All sources of vertical elongation of the anchoring device, such as slip in the connection of the device to the wood post and elongation of the tie-down rod should be considered when estimating the Δ_a term in *SDPWS* Equation 4.3-1. Estimates of Δ_a at strength level forces are needed when evaluating drift in accordance with *ASCE 7* is required.

In shear wall table footnotes (*SDPWS* Table 4.3A), a factor of 0.5 is provided to adjust tabulated G_a values (based on fabricated dry condition) to approximate G_a where “green” framing is used. This factor is based on analysis of apparent shear stiffness for wood structural panel shear wall and diaphragm construction where:

Figure C4.3.2 Comparison of 4-Term and 3-Term Deflection Equations

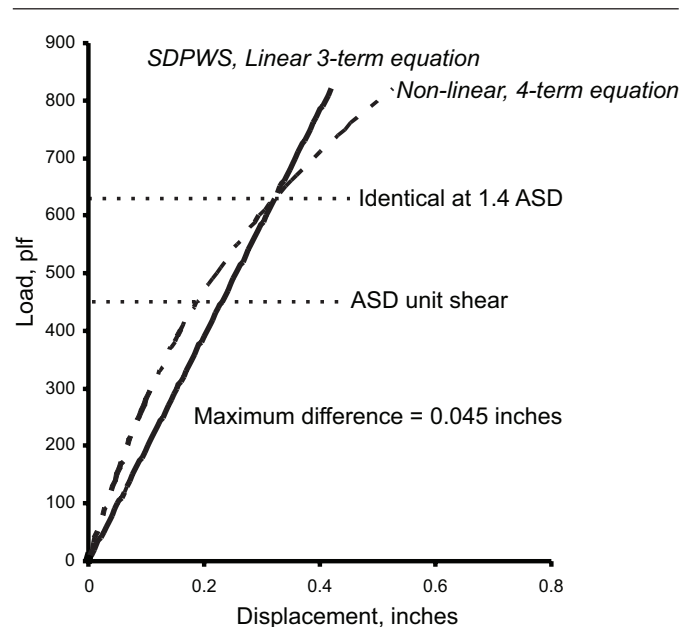

- 1) framing moisture content is greater than 19% at time of fabrication (green), and
- 2) framing moisture content is less than or equal to 19% at time of fabrication (dry).

The average ratio of “green” to “dry” for G_a across shear wall and diaphragm cells ranged from approximately 0.52 to 0.55. A rounded value of 0.5 results in slightly greater values of calculated deflection for “green” framing when compared to the more detailed 4-term deflection equations. Although based on nail slip relationships applicable to wood structural panel shear walls, this reduction is also extended to other shear wall types.

In Table C4.3.2A, calculated deflections using *SDPWS* Equation 4.3-1 are compared to deflections from tests at 1.4 times the allowable design value of the assembly for

shear walls with fiberboard, gypsum sheathing, and lumber sheathing. For lumber sheathing, calculated stiffness is underestimated when compared to test-based stiffness values. However, the lower stated stiffness for horizontal and diagonal lumber sheathing is considered to better reflect stiffness after lumber sheathing dries in service. Early studies (24) suggest that stiffness after drying in service may be 1/2 of that during tests where friction between boards in lumber sheathed assemblies is a significant factor.

Table C4.3.2A Data Summary for Structural Fiberboard, Gypsum Wallboard, and Lumber Sheathed Shear Walls

Reference	Description	Calculated ¹			Actual	
		$1.4V_{s(ASD)}$ (plf)	G_a (kips/in.)	δ (in.)	δ (in.)	G_a (kips/in.)
Structural Fiberboard Sheathing						
Ref. 17	1/2" structural fiberboard, roofing nail (11 gage x 1-3/4"), 2" edge spacing, 6" field spacing, 16" stud spacing. 8' x 8' wall. (3 tests).	364	5.5	0.53	0.46	6.3
	25/32" structural fiberboard, roofing nail (11 gage x 1-3/4"), 2" edge spacing, 6" field spacing, 16" stud spacing. 8' x 8' wall. (3 tests).	378	5.5	0.55	0.53	5.7
Gypsum Wallboard (GWB) Sheathing						
Ref. 23 ²	1/2" GWB both sides applied horizontally, GWB Nail (1-1/4") at 8" o.c., 24" stud spacing. 8' x 8' wall. (3 tests).	184	7.0	0.21	0.17	8.7
	1/2" GWB both sides applied horizontally, GWB Nail (1-1/4") at 8" o.c., 16" stud spacing. 8' x 8' wall. (3 tests).	245	9.6	0.20	0.16	12.2
Lumber Sheathing						
Ref. 24	Horizontal lumber sheathing. 9' x 14' wall. 1 x 6 and 1 x 8 boards. Two 8d nails at each stud crossing. Stud spacing 16" o.c. (3 tests - panel 2A, 33, and 27).	70	1.5	0.42	0.25	3.9
	Diagonal lumber sheathing (in tension), 9' x 14' wall. 1 x 8 boards. Two 8d nails at each stud crossing. Stud spacing 16" o.c. (2 tests – panel 5 and 31).	420	6.0	0.63	0.45	13.1

1. Calculated deflection based on shear component only. For walls tested, small aspect ratio and use of tie-down rods (ASTM E 72) minimize bending and tie-down slip components of deflection.

2. Unit shear and apparent shear stiffness in *SDPWS* Table 4.3B for 7" fastener spacing multiplied by 7/8 to approximate unit shear and stiffness for tested assemblies using 8" fastener spacing.

EXAMPLE C4.3.2-1 Calculate the Apparent Shear Stiffness, G_a , in SDPWS Table 4.3A

Calculate the apparent shear stiffness, G_a , in *SDPWS* Table 4.3A for a wood structural panel shear wall constructed as follows:

Sheathing grade	= Structural I (OSB)
Nail size	= 6d common (0.113" diameter, 2" length)
Minimum nominal panel thickness	= 5/16 in.
Panel edge fastener spacing	= 6 in.
Nominal unit shear capacity for seismic, v_s	= 400 plf <i>SDPWS</i> Table 4.3A

Allowable unit shear capacity for seismic:

$$v_{s(ASD)} = 400 \text{ plf}/2 = 200 \text{ plf}$$

Panel shear stiffness:

$$G_{v,t} = 77,500 \text{ lb/in. of panel depth}$$

Table C4.2.2A

Nail load/slip at $1.4 v_{s(ASD)}$:

$$V_n = \text{fastener load (lb/nail)}$$

$$= 1.4 v_{s(ASD)} (6 \text{ in.})/(12 \text{ in.})$$

$$= 140 \text{ lb/nail}$$

$$e_n = (V_n/456)^{3.144}$$

Table C4.2.2D

$$= (140/456)^{3.144} = 0.0244 \text{ in.}$$

Calculate G_a :

$$G_a = \frac{1.4 v_{s(ASD)}}{\frac{1.4 v_{s(ASD)}}{G_v t_v} + 0.75 e_n} \quad \text{Equation C4.2.2-3}$$

$$G_a = 12,772 \text{ lb/in.} \approx 13 \text{ kips/in.} \quad \text{SDPWS Table 4.3A}$$

C4.3.2.1 Deflection of Perforated Shear Walls: The deflection of a perforated shear wall can be calculated using *SDPWS* Equation 4.3-1 using substitution rules as follows to account for reduced stiffness of full-height perforated shear wall segments:

v = maximum induced unit shear force (plf) in a perforated shear wall per *SDPWS* Equation 4.3-9

b = sum of perforated shear wall segment lengths (full-height), ft

C4.3.2.2 Deflection of Unblocked Wood Structural Panel Shear Walls: Unblocked shear walls exhibit load-deflection behavior similar to that of a blocked shear wall but with reduced values of strength. The unblocked shear wall adjustment factor, C_{ub} , accounts for the effect of unblocked joints on strength and stiffness. Nominal unit shear capacity of a blocked wood structural panel shear wall with stud spacing of 24" o.c. and panel edge nail spacing of 6" o.c. is the reference condition for determination of unblocked shear wall nominal unit shear capacity (e.g. $v_{ub} = v_b C_{ub}$). Blocked shear wall nominal unit shear

capacity is not to be adjusted by Table 4.3A footnote 2 even if unblocked shear wall construction consists of studs spaced a maximum of 16" o.c. or panels applied with the long dimension across studs.

To account for the reduction in unblocked shear wall stiffness, which is proportional to reduction in strength, *SDPWS* 4.3.2.2 specifies that deflection of unblocked shear walls is to be calculated from standard deflection equations using an amplified value of induced unit shear equal to v/C_{ub} . Substituting v/C_{ub} for v in Equation 4.3-1 results in the following equation for shear wall deflection:

$$\delta_{sw} = \frac{8 \left(\frac{v}{C_{ub}} \right) h^3}{EAb} + \frac{\left(\frac{v}{C_{ub}} \right) h}{1000G_a} + \frac{h}{b} \Delta_a \quad \text{(C4.3.2.2-1)}$$

(bending) (shear) (wall anchorage slip)

Where values of C_{ub} are less than 1.0, induced unit shear is amplified by $1/C_{ub}$ resulting in larger deflection for the less stiff unblocked shear wall relative to the blocked shear wall reference condition. The C_{ub} factor can also



be viewed as a stiffness reduction factor. For example, simplification of the shear term in Eq. C4.3.2.2-1 yields:

$$\frac{vh}{1000 (C_{ub} G_a)} \quad (\text{C4.3.2.2-2})$$

where:

$(C_{ub} G_a)$ = Apparent shear stiffness of an unblocked shear wall, G_a unblocked

C4.3.3 Unit Shear Capacities

See C4.2.3 for calculation of ASD unit shear capacity and LRFD factored unit shear resistance. Shear capacity of perforated shear walls is discussed further in section C4.3.3.5.

C4.3.3.1 Tabulated Nominal Unit Shear Capacities: *SDPWS* Table 4.3A provides nominal unit shear capacities for seismic, v_s , and for wind, v_w , (see C2.2) for OSB, plywood, plywood siding, particleboard, and structural fiberboard sheathing. *SDPWS* Table 4.3B provides nominal unit shear capacities for wood structural panels applied over 1/2" or 5/8" gypsum wallboard or gypsum sheathing board. *SDPWS* Table 4.3C provides nominal unit shear capacities for gypsum wallboard, gypsum sheathing, plaster, gypsum lath and plaster, and portland cement plaster (stucco). Nominal unit strength capacities are based on adjustment of allowable values in building codes and industry reference documents (See C2.2).

C4.3.3.2 Unblocked Wood Structural Panel Shear Walls: Monotonic and cyclic tests of unblocked wood structural panel shear walls (18, 27, and 28) are the basis of the unblocked shear wall factor, C_{ub} , which accounts for reduced strength and stiffness of unblocked shear walls when compared to similarly constructed blocked shear walls. Test results show comparable displacement capacity characteristics to similarly constructed blocked wood structural panel shear walls over a range of unblocked panel configurations. Tests included a range of panel edge and field nail spacing, stud spacing, wall height, gap distance at adjacent unblocked panel edges, and simultaneous application of gravity load. The maximum unblocked shear wall height tested was 16' and the maximum gap distance between adjacent unblocked panel edges was 1/2". Maximum unit shear capacities are limited to values applicable for 6" o.c. panel edge nail spacing to address limited observations of stud splitting in walls tested with panel edge nail spacing of 4" o.c.

C4.3.3.3 Summing Shear Capacities: A wall sheathed on two-sides (e.g., a two-sided wall) has twice the capacity of a wall sheathed on one-side (e.g., a one-sided

wall) where sheathing material and fastener attachment schedules on each side are identical. Where sheathing materials are the same on both sides, but different fastening schedules are used, provisions of *SDPWS* 4.3.3.3.1 are applicable. Although not common for new construction, use of different fastening schedules is more likely to occur in retrofit of existing construction.

C4.3.3.3.1 For two-sided walls with the same sheathing material on each side (e.g., wood structural panel) and same fastener type, *SDPWS* Equation 4.3-3 and *SDPWS* Equation 4.3-4 provide for determination of combined stiffness and unit shear capacity based on relative stiffness of each side.

C4.3.3.3.2 For seismic design of two-sided walls with different materials on each side (e.g., gypsum on side one and wood structural panels on side two), the combined unit shear capacity is taken as twice the smaller nominal unit shear capacity or the larger nominal unit shear capacity, whichever is greater. Due to lateral system combination rules for seismic design (5), the two-sided unit shear capacity based on different materials on each side of the wall will require use of the least seismic response modification coefficient, R , for calculation of seismic loads. For a two-sided shear wall consisting of wood-structural panel exterior and gypsum wallboard interior, $R = 2$ is applicable where shear wall design is based on two times the capacity of the gypsum wallboard because $R = 2$ (associated with gypsum wallboard shear walls in a bearing wall system) is the least R contributing to the two-sided shear wall design capacity. For the same wall condition, when design is based on wood structural panel shear wall capacity alone, $R = 6.5$ (associated with wood structural panel shear walls in a bearing wall system) is applicable.

For wind design, direct summing of the contribution of gypsum wallboard with the unit shear capacity of wood structural panel, structural fiberboard, or hardboard panel siding is permitted based on tests (10 and 15).

Figure C4.3.3 illustrates the provisions in Footnote 6 of Table 4.3A and Footnote 5 of Table 4.3B requiring panel joints to be offset to fall on different framing members when panels are applied on both faces of a shear wall, nail spacing is less than 6" on center on either side, and the framing member nailed face width is less than 3x framing.

C4.3.3.5 Shear Capacity of Perforated Shear Walls: The shear capacity adjustment factor, C_o , for perforated shear walls accounts for reduced shear wall capacity due to presence of openings and is derived from empirical Equations C4.3.3.5-1 and C4.3.3.5-2 (13):

$$F = r/(3 - 2r) \quad (\text{C4.3.3.5-1})$$

$$r = 1/(1 + A_o/(h \sum L_i)) \quad (\text{C4.3.3.5-2})$$

Figure C4.3.3 Detail for Adjoining Panel Edges where Structural Panels are Applied to Both Faces of the Wall

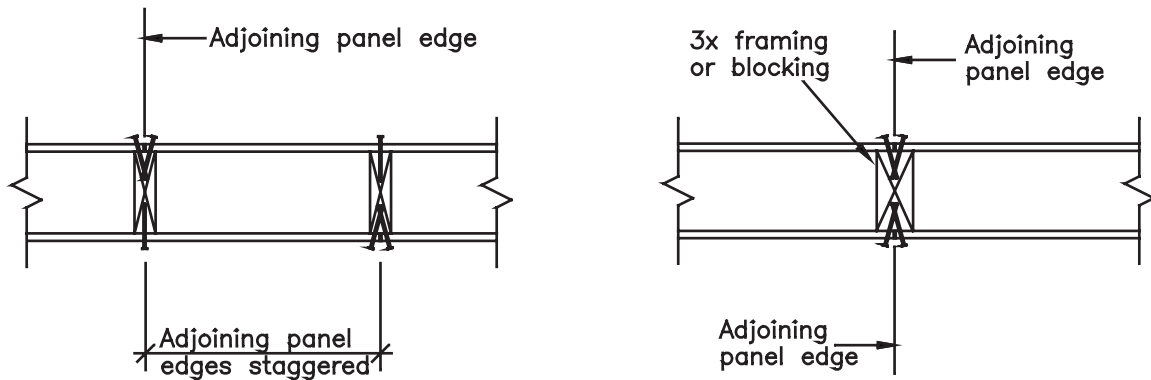

a. Adjoining panel edges staggered

b. Adjoining panel edges not staggered

The opening adjustment factor, C_o , and the shear capacity ratio, F , are related as follows:

$$C_o(\sum L_i) = F(L_{tot}) \quad (C4.3.3.5-3)$$

SDPWS Equation 4.3-5 can be obtained by simplification of C4.3.3.5-1, C4.3.3.5-2, and C4.3.3.5-3.

Values of the shear capacity adjustment factors in Table 4.3.3.5 can be determined by assuming a constant maximum opening height, h_{o-max} , such that $A_o = h_{o-max}(L_{tot} - \sum L_i)$. Substituting this value of A_o into Equation C4.3.3.5-2 and simplifying:

$$C_o = \left(\frac{L_{tot}}{\sum L_i} \right) \left(\frac{\left(1 + \frac{h_{o-max}}{h} \left(\frac{L_{tot}}{\sum L_i} \right) \right)^{-1}}{3 - 2 \left(1 + \frac{h_{o-max}}{h} \left(\frac{L_{tot}}{\sum L_i} \right) \right)^{-1}} \right) \quad (C4.3.3.5-4)$$

where:

C_o = shear capacity adjustment factor (for perforated shear wall segments)

F = shear capacity ratio based on total length of the perforated shear wall

r = sheathing area ratio

A_o = total area of openings, ft²

h = wall height, ft

h_{o-max} = maximum opening height, ft

L_{tot} = total length of a perforated shear wall including lengths of perforated shear wall segments and segments containing openings, ft

$\sum L_i$ = sum of perforated shear wall segment lengths, ft

Full-scale perforated shear wall tests include monotonic and cyclic loads, long perforated shear walls with asymmetrically placed openings, perforated shear walls sheathed on two sides, and perforated shear walls with high aspect ratio shear wall segments (15, 42, 43, and 44).

C4.3.4 Shear Wall Aspect Ratios

The aspect ratio factor, $2b_s/h$, is applicable to blocked wood structural panel shear walls designed to resist seismic forces. The factor ranges in value from 1.0 for 2:1 aspect ratio shear walls to 0.57 for 3.5:1 aspect ratio shear walls and is intended to account for reduced stiffness of high aspect ratio wall segments relative to lower aspect ratio wall segments (such as 1:1 aspect ratio) in the same wall line. Increased contribution of bending and overturning components of shear wall deflection as aspect ratio increases are consistent with findings determined by calculations and monotonic and cyclic tests (35 and 36).

Aspect ratios for structural fiberboard shear walls in Table 4.3.4 are based on strength and stiffness determined from cyclic testing (29). The maximum aspect ratio for structural fiberboard is limited to 3.5:1; however, adjustment factors accounting for reduced strength and stiffness are applicable where the aspect ratio is greater than 1.0.



For seismic design, the aspect ratio reduction factor is based on analysis of reduced stiffness of high aspect ratio walls relative to the reference case (aspect ratio 1:1) and results in a maximum reduction factor of 0.36 at a 3.5:1 aspect ratio. For wind design, the strength reduction factor accounts for observed reduction in peak unit shear strength as aspect ratio increases relative to the reference case and results in a reduction factor of 0.78 at a 3.5:1 aspect ratio.

C4.3.5 Shear Wall Types

SDPWS identifies shear walls as one of the following “types”:

1. Individual Full-Height Wall Segment Shear Walls (i.e., no openings within an individual full-height segment);
2. Force-transfer Shear Walls (i.e., with openings, but framing members, blocking, and connections around openings are designed for force-transfer);
3. Perforated Shear Walls (i.e., with openings, but rather than design for force-transfer around openings, reduced shear strength is used based on size of openings).

C4.3.5.1 Individual Full-Height Wall Segments: Shear wall design provisions for individual full-height wall segments, designed as shear walls without openings, are applicable to walls with wood structural panel sheathing, designed and constructed in accordance with provisions as outlined in *SDPWS* 4.3.5.1.

C4.3.5.2 Force-transfer Shear Walls: Force-transfer shear wall design provisions are applicable to walls with wood structural panel sheathing, designed and constructed in accordance with provisions as outlined in *SDPWS* 4.3.5.2.

C4.3.5.3 Perforated Shear Walls: Perforated shear wall design provisions are applicable to walls with wood structural panel sheathing, designed and constructed in accordance with provisions as outlined in *SDPWS* 4.3.5.3. The single side limits for seismic and wind, 1,740 plf nominal and 2,435 plf nominal respectively, are based on tests utilizing 10d nails at 2” o.c. at panel edges on one side (45). The single side limits on maximum nominal unit shear capacity are also applicable for double-sided walls (walls sheathed on two sides) because the tested walls represent the maximum unit shear strength for which tests are available. The maximum nominal unit shear capacity for seismic design of a double-sided wall, while not explicitly stated in *SDPWS*, is limited to 1,740 plf for consistency with the judgment to limit maximum nominal unit shear capacity for wind based on tests.

Anchorage and load path requirements for perforated

shear walls are specified in *SDPWS* 4.3.6.1.2, 4.3.6.4.1.1, 4.3.6.4.2.1, and 4.3.6.4.4. Anchorage for uplift at perforated shear wall ends, shear, uplift between perforated shear wall ends, and compression chord forces are prescribed to address the non-uniform distribution of shear within a perforated shear wall (7). Prescribed forces for shear and uplift connections are intended to be in excess of the capacity of individual wall segments such that wall capacity based on the sheathing to framing attachment (shear wall nailing) is not limited by bottom plate attachment for shear and/or uplift.

C4.3.6 Construction Requirements

C4.3.6.1 Framing Requirements: Framing requirements are intended to ensure that boundary members and other framing are adequately sized to resist induced loads.

C4.3.6.1.1 Tension and Compression Chords: *SDPWS* Equation 4.3-7 provides for calculation of tension and compression chord force due to induced unit shear acting at the top of the wall (e.g., tension and compression due to wall overturning moment). To provide an adequate load path per *SDPWS* 4.3.6.4.4, design of elements and connections must consider forces contributed by each story (i.e., shear and overturning moment must be accumulated and accounted for in the design).

C4.3.6.1.2 Tension and Compression Chords of Perforated Shear Walls: *SDPWS* Equation 4.3-8 provides for calculation of tension force and compression force at each end of a perforated shear wall, due to shear in the wall, and includes the term $1/C_o$ to account for the non-uniform distribution of shear in a perforated shear wall. For example, a perforated shear wall segment with tension end restraint at the end of the perforated shear wall can develop the same shear capacity as an individual full-height wall segment (7).

C4.3.6.3 Fasteners: Details on type, size, and spacing of mechanical fasteners used for typical shear wall assemblies in Table 4.3A, 4.3B, 4.3C, and 4.3D are provided in *SDPWS* 4.3.7 Shear Wall Systems.

C4.3.6.3.1 Adhesives: Adhesive attachment of shear wall sheathing is generally prohibited unless approved by the authority having jurisdiction. Because of limited ductility and brittle failure modes of rigid adhesive shear wall systems (38) such systems are limited to seismic design categories A, B, and C and the values of R and Ω_o are limited ($R = 1.5$ and $\Omega_o = 2.5$ unless other values are approved). If adhesives are used to attach shear wall sheathing, the effects of increased stiffness (see C4.1.3 and C4.2.5), increased strength, and potential for brittle failure modes corresponding to adhesive or wood failure, should be addressed.

Tabulated values of apparent shear stiffness, G_a , are based on assumed nail slip behavior (see Table C4.2.2D) and are therefore not applicable for adhesive shear wall systems where shear wall sheathing is rigidly bonded to shear wall boundary members.

C4.3.6.4.1.1 In-plane Shear Anchorage for Perforated Shear Walls: *SDPWS* Equation 4.3-9 for in-plane shear anchorage includes the term $1/C_o$ to account for non-uniform distribution of shear in a perforated shear wall. For example, a perforated shear wall segment with tension end restraint at the end of the perforated shear wall can develop the same shear capacity as an individual full-height wall segment (7).

C4.3.6.4.2.1 Uplift Anchorage for Perforated Shear Walls: Attachment of the perforated shear wall bottom plate to elements below is intended to ensure that the wall capacity is governed by sheathing to framing attachment (shear wall nailing) and not bottom plate attachment for shear (see C4.3.6.4.1.1) and uplift. An example design (7) provides typical details for transfer of uplift forces.

C4.3.6.4.3 Anchor Bolts: Plate washer size and location are specified for anchoring of wall bottom plates to minimize potential for cross-grain bending failure in the bottom plate (see Figure C4.3.6.4.3). For a 3" x 3" plate washer centered on the wide face of a 2x4 bottom plate, edges of the plate washer are always within 1/2" of the sheathed side of the bottom plate. For wider bottom plates, such as 2x6, a larger plate washer may be used so that the edge of the plate washer extends to within 1/2" of the sheathed side, or alternatively, the anchor bolt can be located such that the 3" x 3" plate washer extends to within 1/2" of the sheathed side of the wall.

The washer need not extend to within 1/2" of the sheathed edge where sheathing material unit shear capacity is less than or equal to 400 plf nominal. This allowance is based on observations from tests and field performance of gypsum products where sheathing fastener tear-out or sheathing slotting at fastener locations were the dominant failure modes. Other sheathing materials with unit shear capacity less than 400 plf nominal are included in this provision based on the judgment that the magnitude of unit uplift force versus sheathing type is the significant factor leading to potential for bottom plate splitting.

Cyclic testing of wood structural panel shear walls (25 and 30) forms the basis of the exception to the 1/2" distance requirement. In these tests, edge distance was not a significant factor for shear walls having full-overturning restraint provided at end posts. Overturning restraint of wall segments coupled with the nominal capacity of walls tested were viewed as primary factors in determining wall performance and failure limit states.

Bottom plate anchor straps can also be effective in

Figure C4.3.6.4.3 Distance for Plate Washer Edge to Sheathed Edge

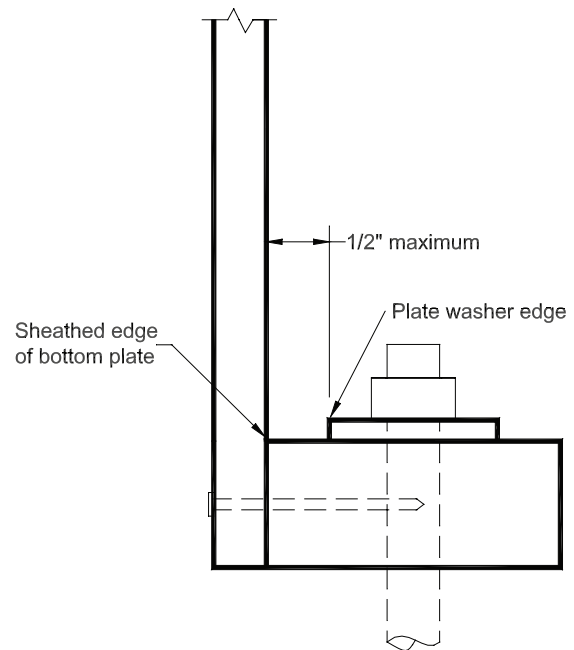

mitigating cross-grain bending failure in the bottom plate provided they have been properly tested, load rated, and installed on the sheathed side of the bottom plate.

C4.3.6.4.4 Load Path: Specified requirements for shear, tension, and compression in *SDPWS* 4.3.6 are to address the effect of induced unit shear on individual wall elements. Overall design of an element must consider forces contributed from multiple stories (i.e., shear and moment must be accumulated and accounted for in the design). In some cases, the presence of load from stories above may increase forces (e.g., effect of gravity loads on compression end posts) while in other cases it may reduce forces (e.g., effect of gravity loads reduces net tension on end posts).

Consistent with a continuous load path for individual full-height wall segments and force transfer shear walls, a continuous load path to the foundation must also be provided for perforated shear walls. Consideration of accumulated forces (for example, from stories above) is required and may lead to increases or decreases in member/connection requirements. Accumulation of forces will affect tie-downs at each end of the perforated shear wall, compression resistance at each end of each perforated shear wall segment, and distributed forces, v and t , at each perforated shear wall segment. Where ends of perforated shear wall segments occur over beams or headers, the beam or header will need to be checked for vertical tension and compression forces in addition to gravity forces. Where

adequate collectors are provided to distribute shear, the average shear in the perforated shear wall above (e.g., equivalent to design shear loads), and not the increased shear for anchorage of upper story wall bottom plates to elements below (7), needs to be considered.

C4.3.7 Shear Wall Systems

Requirements for shear wall sheathing materials, framing, and nailing are consistent with industry recommendations and building code requirements. The minimum width of the nailed face of framing members and blocking for all shear wall types is 2" nominal with maximum spacing between framing of 24". Edges of wood-based panels (wood structural panel, particleboard, and structural fiberboard) are required to be backed by blocking or framing except as specified in 4.3.3.2. In addition, fasteners are to be placed at least 3/8" from edges and ends of panels but not less than distances specified by the manufacturer in the manufacturers' literature or code evaluation report.

C4.3.7.1 Wood Structural Panel Shear Walls: For wood structural panel shear walls, framing members or blocking is required at edges of all panels except as specified in 4.3.3.2 and a minimum panel dimension of 4' x 8' is specified except at boundaries and changes in framing. Shear wall construction is intended to consist primarily of full-size sheets except where wall dimensions require use of smaller sheathing pieces (e.g. where shear wall height or length is not in increments of 4', shear wall height is less than a full 8', or shear wall length is less than 4'). Racking tests conducted on 4.5' x 8.5' blocked shear walls showed similar performance whether sheathed length and height consisted of: one 4'x8' panel and two 6" wide sheathing pieces to make up the height and length, or one 2.5' x 6.5' panel and two 2' wide sheathing pieces to make up the height and length (14).

C4.3.7.1(4): A single 3x framing member is specified at adjoining panel edges for cases prone to splitting and where nominal unit shear capacity exceeds 700 plf in seismic design categories (SDC) D, E, and F. An alternative to single 3x framing, included in *SDPWS*, and based on principles of mechanics, is the use of 2-2x "stitched" members adequately fastened together. Cyclic tests of shear walls confirms that use of 2-2x members nailed (22, 25, and 30) or screwed (33) together results in shear wall performance that is comparable to that obtained by use of a single 3x member at the adjoining panel edge. Attachment of the 2-2x members to each other is required to equal or exceed design unit shear forces in the shear wall. As an alternative, a capacity-based design approach can be used where the connection between the 2-2x members equals or exceeds the capacity of the sheathing to framing attach-

ment. Where fastener spacing in the "stitched" members at adjoining panel edges is closer than 4" on center, staggered placement is required.

For sheathing attachment to framing with closely spaced or larger diameter nails, staggered nail placement at each panel edge is intended to prevent splitting in the framing member (see Figure C4.2.7.1.1(3)).

C4.3.7.2 Shear Walls using Wood Structural Panels over Gypsum Wallboard or Gypsum Sheathing Board: Shear walls using wood structural panels applied over gypsum wallboard or gypsum sheathing are commonly used for exterior walls of buildings that are fire-rated for both interior and exterior exposure. For example, a one-hour fire resistance rating can be achieved with 5/8" Type X gypsum wallboard.

Nominal unit shear capacities and apparent shear stiffness values in Table 4.3B for 8d and 10d nails are based on nominal unit shear capacities and apparent shear stiffness values in Table 4.3A for 6d and 8d nails, respectively, to account for the effect of gypsum wallboard or gypsum sheathing between wood framing and wood structural panel sheathing. Tests of 3/8" wood structural panels over 1/2" and 5/8" gypsum wallboard support using lower nominal unit shear capacities associated with smaller nails (18).

C4.3.7.3 Particleboard Shear Walls: Panel size requirements are consistent with those for wood structural panels (see C4.3.7.1). Apparent shear stiffness in *SDPWS* Table 4.3A is based on assumptions of relative stiffness and nail slip (see C4.2.2 and C4.3.2). For closely spaced or larger diameter nails, staggered nail placement at each panel edge is intended to prevent splitting in the framing member (see figure C4.2.7.1.1(3)).

C4.3.7.4 Structural Fiberboard Shear Walls: Panel size requirements are consistent with those for wood structural panels (see C4.3.7.1). Apparent shear stiffness in *SDPWS* Table 4.3A is based on assumptions of relative stiffness and nail slip (see C4.2.2 and C4.3.2). Minimum panel edge distance for nailing at top and bottom plates is 3/4" to match edge distances present in cyclic tests of high aspect ratio structural fiberboard shear walls (29).

C4.3.7.5 Gypsum Wallboard, Gypsum Veneer Base, Water-Resistant Backing Board, Gypsum Sheathing, Gypsum Lath and Plaster, or Portland Cement Plaster Shear Walls: The variety of gypsum-based sheathing materials reflects systems addressed in the model building code (2). Appropriate use of these systems requires adherence to referenced standards for proper materials and installation. Where gypsum wallboard is used as a shear wall, edge fastening (e.g. nails or screws) in accordance with *SDPWS* Table 4.3C requirements should be specified and overturning restraint provided where applicable (see *SDPWS* 4.3.6.4.2). Apparent shear stiffness in *SDPWS*

Table 4.3C is based on assumptions of relative stiffness and nail slip (see C4.2.2 and C4.3.2). The nominal unit shear capacity and apparent shear stiffness values for plain or perforated gypsum lath with staggered vertical joints are based on results from cyclic tests (31). Unit shear capacity and apparent shear stiffness values are larger than those for plain or perforated gypsum lath where vertical joints are not staggered.

C4.3.7.6 Shear Walls Diagonally Sheathed with Single-Layer of Lumber: Diagonally sheathed lumber shear walls have comparable strength and stiffness to many wood structural panel shear wall systems. Apparent shear stiffness in *SDPWS* Table 4.3D is based on assumptions of relative stiffness and nail slip (see C4.2.2 and C4.3.2). Early reports (24) indicated that diagonally sheathed lumber shear walls averaged four times the rigidity of horizontally sheathed lumber walls when boards were loaded primarily in tension. Where load was primarily in

compression, a single test showed about seven times the rigidity of a horizontally sheathed lumber wall.

C4.3.7.7 Shear Walls Diagonally Sheathed with Double-Layer of Lumber: Double diagonally sheathed lumber shear walls have comparable strength and stiffness to many wood structural panel shear wall systems. Apparent shear stiffness in *SDPWS* Table 4.3D is based on assumptions of relative stiffness and nail slip (see C4.2.2 and C4.3.2).

C4.3.7.8 Shear Walls Horizontally Sheathed with Single-Layer of Lumber: Horizontally sheathed lumber shear walls have limited unit shear capacity and stiffness when compared to those provided by wood structural panel shear walls of the same overall dimensions. Early reports (21 and 24) attributed strength and stiffness of lumber sheathed walls to nail couples at stud crossings and verified low unit shear capacity and stiffness when compared to other bracing methods.

C4.4 Wood Structural Panels Designed to Resist Combined Shear and Uplift from Wind

C4.4.1 Application

Panels with a minimum thickness of 7/16" and strength axis oriented parallel to studs are permitted to be used in combined uplift and shear applications for resistance to wind forces. Tabulated values of nominal uplift capacity (see *SDPWS* Table 4.4.1) for various combinations of nailing schedules and panel type and thickness are based on calculations in accordance with the *National Design Specification (NDS) for Wood Construction* and verified by full-scale testing (39 and 40).

ASD and LRFD unit uplift and shear capacities are calculated as follows from nominal unit uplift and shear values.

ASD unit uplift capacity for wind, $u_{w(ASD)}$:

$$u_{w(ASD)} = \frac{u_w}{2.0} \quad (C4.4.1-1)$$

ASD unit shear capacity for wind, $v_{w(ASD)}$:

$$v_{w(ASD)} = \frac{v_w}{2.0} \quad (C4.4.1-2)$$

where:

2.0 = ASD reduction factor

LRFD unit uplift capacity for wind, $u_{w(LRFD)}$:

$$u_{w(LRFD)} = 0.65u_w \quad (C4.4.1-3)$$

LRFD unit shear capacity for wind, $v_{w(LRFD)}$:

$$v_{w(LRFD)} = 0.8v_w \quad (C4.4.1-4)$$

where:

0.65 = resistance factor, ϕ_z , for connections

0.8 = resistance factor, ϕ_D , for shear walls and diaphragms

Examples C4.4.1-1 and C4.4.2-1 illustrate how the values in *SDPWS* Tables 4.4.1 and 4.4.2, respectively, were generated. Tabulated values of nominal uplift capacity in Table 4.4.1 and Table 4.4.2 are based on assumed use of framing with specific gravity, G , equal to 0.42. An increase factor is provided in table footnotes to adjust values for effect of higher specific gravity framing on the strength of the nailed connection between sheathing and framing. Where lower specific gravity framing is used, reduced values of nominal uplift capacity are applicable based on the effect of lower specific gravity framing on the strength of the nailed connection between sheathing and framing – for example, the reduction factor is 0.92 for framing with $G=0.35$. Adjustment factors over a range



of framing specific gravity can be determined as follows: Specific Gravity Adjustment Factor = $[1 - (0.5 - G)] / 0.92$ for $0.35 \leq G \leq 0.49$.

C4.4.1.2 Panels: Full-scale testing (see C4.4.1) utilized panels with strength axis oriented parallel to studs. *NDS* nail connection capacities are independent of panel strength axis orientation, however, panel strength in tension perpendicular to the strength axis is typically less than panel strength in tension parallel to the strength axis. For applications where panel strength axis is oriented perpendicular to studs, manufacturer recommendations should be followed.

C4.4.1.6. Sheathing Extending to Bottom Plate or Sill Plate: Construction requirements for use of wood structural panels to resist uplift and shear closely match construction present in verification tests. For example, testing of shear walls resisting uplift and combined uplift and shear used 16" o.c. anchor bolt spacing, 3"x3" plate washers, and nails with minimum 1/2" to 3/4" panel edge distance depending on the number of rows of nails. Anchor bolt spacing and size and location of plate washers were found to be important factors enabling strength of the sheathing to bottom plate connection to develop prior to onset of bottom plate failure. Where other anchoring devices are used, it is intended that spacing not exceed 16" o.c. and in addition that such devices enable performance of walls to be comparable to those tested with required anchor bolts and plate washers.

C4.4.1.7 Sheathing Splices: In multi-story applications where the upper story and lower story sheathing adjoin over a common horizontal framing member, the connection of the sheathing to the framing member can be designed to maintain a load path for tension and shear. It is recognized that wood is directly stressed in tension perpendicular to grain in some details; however, those cases are prescriptively permitted and also limited to nail size and spacing verified by testing. Splice panel orientation does not affect capacity of the sheathed tension splice joint and therefore panel orientation can be either parallel or perpendicular to studs.

C4.4.1.7(1) Where sheathing edges from the upper and lower story meet over a common horizontal framing member, wood stressed in tension perpendicular to grain is relied upon directly to maintain load path for tension (see Figure C4.4.1.7(1)). The location of sheathing splices need not occur at mid-height of the horizontal framing. Wall height, floor depth, available panel lengths, and maintaining minimum edge distances between sheathing nails and framing will influence the practical location of the sheathing splice in the horizontal framing member. Wood member stresses in this application are limited to that which can be developed with nail spacing to 3" o.c.

(minimum) for a single-row and 6" o.c. (minimum) for a double-row at each panel edge based on results from testing. Limiting tension stresses perpendicular to grain in horizontal framing members is accomplished by limiting nail spacing to 3" o.c. (minimum) for a single-row and 6" o.c. (minimum) for a double-row. This limitation does not preclude use of more closely spaced nails where the horizontal framing member is an engineered rim board or similar product that can resist higher induced tension stresses perpendicular to grain. Follow manufacturers' recommendations for minimum nail spacing permitted for this application.

Figure C4.4.1.7(1) Panel Splice Over Common Horizontal Framing Member

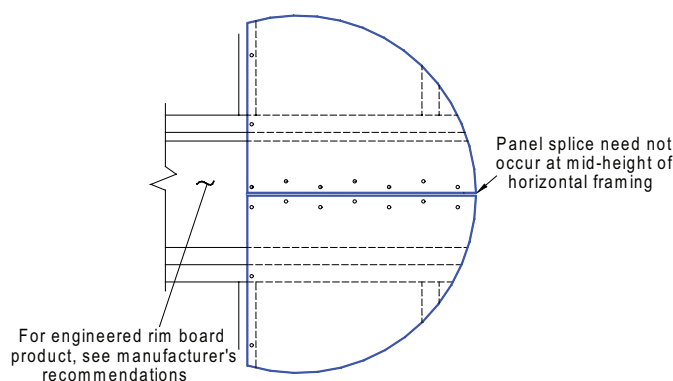

C4.4.1.7(2) The panel splice across studs detail in Figure 4I relies on increased nailing between vertical framing (e.g. studs) and sheathing to transfer tension forces while shear is transferred through nailed connections to horizontal framing such as horizontal blocking. This detail assumes no direct loading of framing members in tension perpendicular to grain for development of the tension load path. Additional nailing between sheathing and vertical framing on each side of the panel splice maintains load path for tension. Where the panel is continuous between stories, as shown in Figure 4I, one option to maintain load path for shear utilizes attachment of sheathing to wall plate framing as shown in Figure C4.4.1.7(2).

C4.4.2 Wood Structural Panels Designed to Resist Only Uplift from Wind

Panels with a minimum thickness of 3/8" are permitted to be used in this application to resist uplift from wind only when panels are installed with the strength axis parallel to studs (see SDPWS 4.4.1 for provisions on resistance

to combined shear and uplift from wind). Tabulated unit uplift capacities are applicable for wood structural panels with 3/8" and greater thickness. For applications where

panel strength axis is oriented perpendicular to studs, manufacturer recommendations should be followed.

Figure C4.4.1.7(2) Detail for Continuous Panel Between Levels (Load Path for Shear Transfer Into and Out of the Diaphragm Not Shown)

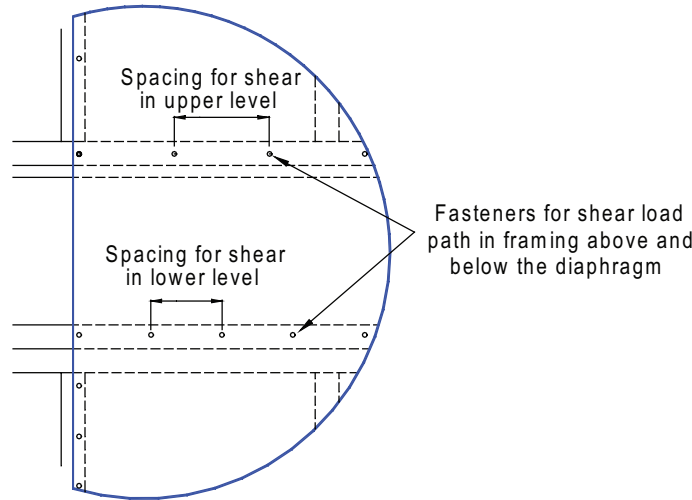

Continuous panel between levels

EXAMPLE C4.4.1-1 Calculate Nominal Uplift Capacity for Combined Uplift and Shear Case

Calculate the nominal uplift capacity in *SDPWS* Table 4.4.1 for a wood structural panel shear wall constructed as follows:

- Sheathing grade = Structural I (OSB)
- Nail size = 10d common (0.148" diameter, 3" length)
- Minimum nominal panel thickness = 15/32"
- Nailing for shear = 6" panel edge spacing (2 nails per foot), 12" field spacing
- Alternate nail spacing at top and bottom plate edges = 3" (single row, 4 nails per foot)
- Nails available for uplift = Nails from alternate nail spacing – Nails available for shear only
= 4 nails per foot – 2 nails per foot = 2 nails per foot

$Z = 82 \text{ lb NDS Table 11Q (Main member: } G = 0.42 \text{ (SPF), Side member: } 15/32" \text{ OSB)}$
 $C_D = 1.6$ *NDS* Table 2.3.2
 $Z' = 82 \text{ lb} \times 1.6 = 131 \text{ lb}$

Allowable uplift capacity = 131 lb x 2 nails/foot = 262 plf

Nominal uplift capacity = 262 plf x ASD reduction factor

Nominal uplift capacity = 262 plf x 2 = 524 plf
SDPWS Table 4.4.1

When subjected to combined shear and wind uplift forces, the calculation for nominal uplift capacity is based on the assumption that nails resist either shear or wind uplift forces.



EXAMPLE C4.4.2-1 Calculate Nominal Uplift Capacity for Wind Uplift Only Case

Calculate nominal uplift capacity, in *SDPWS* Table 4.4.2 for wood structural panel sheathing over framing constructed as follows:

Sheathing grade	=	Structural I (OSB)
Nail size	=	10d common (0.148" diameter, 3" length)
Minimum nominal panel thickness	=	3/8"
Alternate nail spacing at top and bottom plate edges	=	3" (single row, 4 nails per foot)
Nails available for uplift	=	Nails from alternate nail spacing = 4 nails per foot

$Z = 78$ lb *NDS* Table 11Q (Main member:

$G = 0.42$ (SPF), Side member: 3/8" OSB)

$C_D = 1.6$

NDS Table 2.3.2

$Z' = 78 \times 1.6 = 125$ lb

Allowable uplift capacity = 125 lb x 4 nails/ft = 500 plf

Nominal uplift capacity = 500 plf x ASD reduction factor

Nominal uplift capacity = 500 plf x 2 = 1,000 plf

SDPWS Table 4.4.2

COMMENTARY REFERENCES

1. ASTM Standard D 6555-03, Standard Guide for Evaluating System Effects in Repetitive-Member Wood Assemblies, ASTM, West Conshohocken, PA, 2003.
2. International Building Code (IBC), International Code Council, Falls Church, VA, 2006.
3. Laboratory Report 55, Lateral Tests on Plywood Sheathed Diaphragms (out of print), Douglas Fir Plywood Association (now APA-The Engineered Wood Association), Tacoma, WA, 1952.
4. Laboratory Report 63a, 1954 Horizontal Plywood Diaphragm Tests (out of print), Douglas Fir Plywood Association (now APA-The Engineered Wood Association), Tacoma, WA, 1955.
5. Minimum Design Loads for Buildings and Other Structures, American Society of Civil Engineers, ASCE/SEI Standard 7-05. Reston, VA, 2006.
6. National Design Specification (NDS) for Wood Construction, ANSI/AF&PA NDS-2005, American Forest & Paper Association, Washington, DC, 2005.
7. NEHRP Recommended Provisions for Seismic Regulations for New Buildings and Other Structures and Commentary, FEMA Report 450-1 and 2, 2003 Edition, Washington, DC, 2004.
8. Performance Standard for Wood-Based Structural Use Panels, DOC PS2-04. United States Department of Commerce, National Institute of Standards and Technology, Gaithersburg, MD, 2004.
9. Polensek, Anton. Rational Design Procedure for Wood-Stud Walls Under Bending and Compression, Wood Science, July 1976.
10. Racking Load Tests for the American Fiberboard Association and the American Hardboard Association, PFS Test Report #01-25, Madison, WI, 2001.
11. Report 106, 1966 Horizontal Plywood Diaphragm Tests (out of print), Douglas Fir Plywood Association (now APA-The Engineered Wood Association), APA, Tacoma, WA, 1966.
12. Ryan, T. J., K. J. Fridley, D. G. Pollock, and R. Y. Itani, Inter-Story Shear Transfer in Woodframe Buildings: Final Report, Washington State University, Pullman, WA, 2001.
13. Sugiyama, Hideo, 1981, The Evaluation of Shear Strength of Plywood-Sheathed Walls with Openings, Mokuzai Kogyo (Wood Industry) 36-7, 1981.
14. Using Narrow Pieces of Wood Structural Panel Sheathing in Wood Shear Walls, APA T2005-08, APA- The Engineered Wood Association, Tacoma, WA, 2005.
15. Wood Structural Panel Shear Walls with Gypsum Wallboard and Window/Door Openings, APA 157, APA- The Engineered Wood Association, Tacoma, WA, 1996.
16. ASTM Standard D 5457-04, Standard Specification for Computing the Reference Resistance of Wood-Based Materials and Structural Connections for Load and Resistance Factor Design, ASTM, West Conshohocken, PA, 2004.
17. Racking Load Tests for the American Fiberboard Association, PFS Test Report #96-60, Madison, WI, 1996.
18. Wood Structural Panel Shear Walls, Research Report 154, APA-The Engineered Wood Association, Tacoma, WA, 1999.
19. Plywood Diaphragms, Research Report 138, APA-The Engineered Wood Association, Tacoma, WA, 1990.
20. Wood Frame Construction Manual (WFCM) for One- and Two-Family Dwellings, ANSI/AF&PA WFCM-2001, American Forest & Paper Association, Washington, DC, 2001.
21. Luxford, R. F. and W. E. Bonser, Adequacy of Light Frame Wall Construction, No. 2137, Madison, WI: U.S. Department of Agriculture, Forest Service, Forest Products Laboratory, 1958.



22. Shear Wall Lumber Framing: 2x's vs. Single 3x's at Adjoining Panel Edges, APA Report T2003-22, APA-The Engineered Wood Association, Tacoma, WA, 2003.
23. Racking Strengths and Stiffnesses of Exterior and Interior Frame Wall Constructions for Department of Housing and Urban Development, Washington, D.C., NAHB Research Foundation, Inc., May, 1971.
24. The Rigidity and Strength of Frame Walls, No. 896, Madison, WI, U.S. Department of Agriculture, Forest Service, Forest Products Laboratory, March 1956.
25. Rosowsky, D., L. Elkins, and C. Carroll, Cyclic Tests of Engineered Shear Walls Considering Different Plate Washer Sizes, Oregon State University, Corvallis, OR, 2004.
26. Stillinger, J.R., Lateral Tests on Full-scale Lumber-sheathed Roof Diaphragms, Report No.T-6, Oregon State University, Corvallis, OR, 1953.
27. Ni, C. and E. Karacabeyli, Effect of Blocking in Horizontally Sheathed Shear Walls, Wood Design Focus, Forest Products Society, Volume 12, Number 2, Summer, 2002.
28. Mi, H., C. Ni, Y. H. Chui, and E. Karacabeyli, Racking Performance of Tall Unblocked Shear Walls, ASCE Journal of Structural Engineering, Volume 132, Number 1, 145-152, 2006.
29. Cyclic Testing of Fiberboard Shear Walls with Varying Aspect Ratios, NAHB Research Center, Upper Marlboro, MD, 2006.
30. Gupta, R., H. Redler, and M. Clauson, Cyclic Tests of Engineered Shear Walls Considering Different Plate Washer Sizes (Phase II), Oregon State University, Corvallis, OR, 2007.
31. Schmid, B. Proposal S98. International Code Council Proposed Changes to the 2006 International Building Code, Volume I, Country Club Hills, IL, June 2006
32. Shear Capacity of Continuous Joints in High-Load Diaphragms, APA Report T2001L-72, Tacoma, WA, 2001.
33. Line, P., N. Waltz, and T. Skaggs, Seismic Equivalence Parameters for Engineered Wood-frame Wood Structural Panel Shear Walls, Wood Design Focus, July 2008.
34. ASTM E 2126-07, Standard Test Methods for Cyclic (Reversed) Load Test for Shear Resistance of Walls for Buildings. ASTM International, West Conshohocken, PA, 2007.
35. Salenikovich, A. J. and J. D. Dolan, Racking Performance of Shear Walls with Various Aspect Ratios: Part I - Monotonic Tests of Fully Anchored Walls. Forest Products Journal, 53(10): 65-73, Forest Products Society, Madison, WI, 2003.
36. Salenikovich, A. J. and J. D. Dolan, Racking Performance of Shear Walls with Various Aspect Ratios: Part II - Cyclic Tests of Fully Anchored Walls. Forest Products Journal, 53(10), Forest Products Society, Madison, WI, 2003.
37. Krawinkler, H., F. Parisi, L. Ibarra, A. Ayoub, and R. Medina, Development of a Testing Protocol for Wood Frame Structures, CUREE Publication No. W-02, 2000.
38. Filiatrault, A. and R. O. Foschi, Static and Dynamic Tests of Timber Shear Walls Fastened with Nails and Wood Adhesive. Canadian Journal of Civil Engineering 18: 749-755. 1991.
39. Combined Shear and Wind Uplift Tests on 7/16-inch Oriented Strand Board Panels, APA-The Engineered Wood Association, Tacoma, WA, May, 2007.
40. Combined Shear and Wind Uplift Tests with 10d Common Nails, APA-The Engineered Wood Association, Tacoma, WA, March, 2008.
41. ASTM E 72-05 Standard Test Methods of Conducting Strength Tests of Panels for Building Construction. ASTM International, West Conshohocken, PA, 2005.
42. Preliminary Perforated Shear Wall Testing. APA Report T2005-83. APA-The Engineered Wood Association, Tacoma, WA, 2005.
43. Dolan, J. D. and A. C. Johnson, Monotonic Tests of Long Shear Walls with Openings, Report No. TE-1996-001, Virginia Tech, Brooks Forest Products Research Center, Blacksburg, VA, 1997.

44. Dolan, J. D. and A. C. Johnson, Monotonic Tests of Long Shear Walls with Openings, Report No. TE-1996-002, Virginia Tech, Brooks Forest Products Research Center, Blacksburg, VA, 1997.
45. Preliminary Perforated Shear Wall Testing, Report T2005-83, APA-The Engineered Wood Association, Tacoma, WA, December, 2005.



American Wood Council

Engineered and Traditional Wood Products

AWC Mission Statement

To increase the use of wood by assuring the broad regulatory acceptance of wood products, developing design tools and guidelines for wood construction, and influencing the development of public policies affecting the use of wood products.

**American Forest & Paper Association
American Wood Council
1111 19th Street, NW
Suite 800
Washington, DC 20036
www.awc.org
awcinfo@afandpa.org**

***America's Forest & Paper People[®]
Improving Tomorrow's Environment Today[®]***

A F & P A [®]



ISBN 0-9786245-9-9



9

06-09