

ASCE STANDARD

American Society of Civil Engineers

Design of Latticed Steel Transmission Structures

This document uses both Système International (SI) units and customary units.

ASCE 10-97

American Society of Civil Engineers

Design of Latticed Steel Transmission Structures

This document uses both Système International (SI) units and customary units.



Published by the American Society of Civil Engineers
1801 Alexander Bell Drive
Reston, Virginia 20191-4400

ABSTRACT

This standard provides requirements for the design of guyed and self-supporting latticed steel electrical transmission structures. They are applicable for hot-rolled and cold-formed steel shapes. Analysis techniques are outlined for the geometrical configurations presently in use. Procedures for the design of individual members reflect extensive experience and test data on steels with yield points up to 65 ksi. Connection design procedures allow the engineer to match connection capability to the most suitable end and edge distances for detailing. If full-scale structure testing is required, procedures are outlined to assist in obtaining critical information. Design procedures cover structural steel members and connections used in foundations. The commentary provides supporting background data.

Library of Congress Cataloging-in-Publication Data

Design of latticed steel transmission structures / American Society of Civil Engineers.

p. cm. — (ASCE standard)

“ASCE 10-97.”

ISBN 0-7844-0324-4

1. Electric lines—Poles and towers—Design and construction. 2. Electric lines—Poles and towers—Testing. 3. Steel, Structural—Testing. I. American Society of Civil Engineers. II. Series: American Society of Civil Engineers. ASCE standard.

TH3242.D45 1998

621.319'22—dc21

98-41267

CIP

Photocopies. Authorization to photocopy material for internal or personal use under circumstances not falling within the fair use provisions of the Copyright Act is granted by ASCE to libraries and other users registered with the Copyright Clearance Center (CCC) Transactional Reporting Service, provided that the base fee of \$8.00 per article plus \$.50 per page is paid directly to CCC, 222 Rosewood Drive, Danvers, MA 01923. The identification for ASCE Books is 0-7844-0324-4/00/\$8 + .50. Requests for special permission or bulk copying should be addressed to Permissions & Copyright Dept., ASCE.

Copyright © 2000 by the American Society of Civil Engineers, All Rights Reserved.

Library of Congress Catalog Card No: 98-41267

ISBN 0-7844-0324-4

Manufactured in the United States of America.

FOREWORD

The material presented in this Standard has been prepared in accordance with recognized engineering principles. This Standard and Commentary should not be used without first securing competent advice with respect to their suitability for any given application. The publication of the material contained herein is not intended as a representation or warranty on the

part of the American Society of Civil Engineers, or of any other person named herein, that this information is suitable for any general or particular use or promises freedom from infringement of any patent or patents. Anyone making use of this information assumes all liability from such use.

This page intentionally left blank

ACKNOWLEDGMENTS

In 1971, the American Society of Civil Engineers (ASCE) published the *Guide for Design of Steel Transmission Towers, Manuals, and Reports on Engineering Practice—No. 52*. Manual 52 has been used extensively in the United States and abroad as the basis for design specifications. In 1984, an ASCE task committee was established for updating Manual 52 to reflect new design procedures, availability of new shapes and materials, changes in loading criteria, and results of new test data. The second edition was published in 1988. In 1986, it was proposed that ASCE form a committee to develop a standard. The committee was established in 1987 and was chaired by Gene M. Wilhoite. The second edition of Manual 52 served as a resource in developing this Standard, although some of the formulas and examples differ slightly from those in the Manual. The previous work of the ASCE task committee on Manual 52 is greatly

appreciated. The first edition of ANSI/ASCE 10 was approved by ANSI on December 9, 1991.

In 1992 the committee began considering revisions to the first edition. At that time it was determined that the Standard had not been in use long enough to warrant substantial changes to the design requirements; however, it was decided that all relevant illustrations and examples from previous editions of Manual 52 required for the proper implementation of the standard would be incorporated into this revision.

This Standard was prepared through the consensus standards process by balloting in compliance with procedures of ASCE's Management Group F on Codes and Standards. Those individuals who serve on the Design of Steel Transmission Towers Standards Committee are:

Abolhassan Astaneh-Asl
Edward P. Becker
David G. Brinker
Donald D. Cannon, Jr.
Bing C. Chan
Clayton L. Clem, Chair
Dana R. Crissey
Martin L. De la Rosa
George E. Fortney
Charles Garcia
Edwin H. Gaylord
Jerome G. Hanson
Leon Kempner, Jr., Secretary

Massoud Khavari, Vice Chair
William A. Klenk
Jacob Kramer
Richard A. Kravitz
Walter P. Moore, Jr.
Robert E. Nickerson
Robert L. Patterson
Alain H. Peyrot
Ronald E. Randle
David Tennent
Harold N. Wentzel
Leslie H. Williams
Adolfo Zavelani-Rossi

The Committee thanks Ms. Rhonda L. Raty for her secretarial support and patience during the development and revision of this Standard.

This page intentionally left blank

CONTENTS

	Page
STANDARDS	iii
FOREWORD	v
ACKNOWLEDGMENTS	vii
1.0 General	1
1.1 Scope.....	1
1.2 Applicable Documents.....	1
1.3 Definitions.....	1
2.0 Loading, Geometry, and Analysis	2
2.1 Introduction	2
2.2 Loads.....	2
2.3 Geometric Configurations.....	2
2.4 Methods of Analysis	2
3.0 Design of Members.....	2
3.1 Introduction	2
3.2 Material	2
3.3 Minimum Sizes	3
3.4 Slenderness Ratios	3
3.5 Properties of Sections.....	3
3.6 Design Compression Stress	3
3.7 Compression Members: Angles	3
3.7.1 Maximum <i>w/t</i> Ratio	3
3.7.2 Design Compressive Stress.....	3
3.7.3 Determination of F_a	4
3.7.4 Effective Lengths.....	4
3.7.4.1 Leg Members.....	4
3.7.4.2 Other Compression Members.....	4
3.7.4.3 Redundant Members.....	5
3.7.4.4 Unsupported Length with Varying Forces	6
3.7.4.5 Joint Restraint	6
3.7.4.6 Test Verification.....	6
3.8 Compression Members: Symmetrical Lipped Angles	6
3.8.1 Maximum <i>w/t</i> Ratio	6
3.8.2 Design Compressive Stress.....	6
3.8.3 Equivalent Radius of Gyration	6
3.8.4 Minimum Lip Depth	7
3.9 Compression Members Not Covered in Sections 3.7 and 3.8	7
3.9.1 Design Compressive Stress.....	7
3.9.2 Maximum <i>w/t</i> Ratio	7
3.9.3 Effective Widths of Elements in Compression	7
3.9.3.1 Uniformly Compressed Elements.....	7
3.9.3.2 Elements with Stress Gradient	8
3.9.4 Doubly Symmetric Open Cross-Sections.....	8
3.9.5 Singly Symmetric Open Cross-Sections.....	8
3.9.6 Point-Symmetric Open Cross-Sections.....	9
3.9.7 Closed Cross-Sections	9
3.9.8 Nonsymmetric Cross-Sections.....	9
3.9.9 Lips.....	9
3.9.10 Eccentric Connections	9

3.10	Tension Members.....	9
3.10.1	Design Tensile Stress.....	9
3.10.2	Angle Members.....	9
3.10.3	Eccentric Connections	9
3.10.4	Threaded Rods and Anchor Bolts	9
3.10.5	Guys.....	10
3.11	Stitch Bolts.....	10
3.12	Axial Compression and Bending	10
3.13	Axial Tension and Bending	11
3.14	Beams.....	11
3.14.1	Properties of Sections.....	11
3.14.2	Design Tension.....	11
3.14.3	Laterally Supported Beams.....	11
3.14.4	I, Channel, and Cruciform Sections	11
3.14.5	Other Doubly Symmetric Open Sections	12
3.14.6	Singly Symmetric I and T Sections.....	12
3.14.7	Other Singly Symmetric Open Sections.....	12
3.14.8	Equal Leg Angles	12
3.15	Design Shear.....	14
3.15.1	Beam Webs.....	14
3.15.2	Angles	14
3.16	Test Verification.....	14
4.0	Design of Connections.....	15
4.1	Introduction	15
4.2	General Requirements.....	15
4.3	Fasteners	15
4.3.1	Materials	15
4.3.2	Bolt Shear Capacity	15
4.3.3	Bolt Tension Capacity	15
4.3.4	Bolts Subject to Combined Shear and Tension.....	15
4.4	Design Bearing Stress.....	15
4.5	Minimum Distances	15
4.5.1	End Distance.....	15
4.5.2	Center-to-Center Bolt Hole Spacing.....	16
4.5.3	Edge Distance	16
4.6	Attachment Holes	16
4.7	Test Verification.....	16
5.0	Detailing and Fabrication	16
5.1	Detailing	16
5.1.1	Drawings.....	16
5.1.2	Approval of Shop Drawings	16
5.1.3	Connections	17
5.1.4	Bolt Spacing	17
5.1.5	Detail Failures During Testing	17
5.1.6	Material	17
5.1.7	Weathering Steel.....	17
5.1.8	Tension-Only Members.....	17
5.1.9	Shop Check Assembly.....	17
5.1.10	Other Considerations	17

5.2	Fabrication.....	17
5.2.1	Material	17
5.2.2	Specifications	17
5.2.3	Shop Operations	17
5.2.4	Piece Marks.....	18
5.2.5	Welding.....	18
5.2.6	Galvanizing	18
5.2.7	Shipping.....	18
6.0	Testing.....	18
6.1	Introduction	18
6.2	Foundations	18
6.3	Material	18
6.4	Fabrication.....	18
6.5	Strain Measurements	18
6.6	Assembly and Erection	18
6.7	Test Loads.....	19
6.8	Load Application	19
6.9	Loading Procedure.....	19
6.10	Load Measurement.....	19
6.11	Deflections.....	19
6.12	Failures	19
6.13	Disposition of Prototype	19
6.14	Report.....	20
7.0	Structural Members and Connections Used in Foundations.....	20
7.1	Introduction	20
7.2	General Considerations	20
7.2.1	Steel Grillages.....	20
7.2.2	Pressed Plates	21
7.2.3	Stub Angles	21
7.2.4	Anchor Bolts.....	21
7.2.4.1	Smooth Bars with Base Assembly in Contact with Concrete or Grout.....	21
7.2.4.2	Deformed Bars with Base Assembly in Contact with Concrete or Grout.....	21
7.2.4.3	Smooth or Deformed Bars with Base Assembly Not in Contact with Concrete or Grout.....	21
7.3	Deterioration Considerations	22
7.4	Design of Stub Angles and Anchor Bolts.....	22
7.4.1	Stub Angles in Concrete	22
7.4.2	Anchor Bolts with Base Assembly in Contact with Concrete or Grout	22
7.5	Design Requirements for Concrete and Reinforcing Steel.....	23
7.5.1	Stub Angles	23
7.5.2	Smooth Bar Anchor Bolts	23
7.5.2.1	Minimum Embedment for Anchor Bolts	23
7.5.3	Deformed Bar Anchor Bolts	23
7.6	Shear Connectors	24
7.6.1	Stud Shear Connectors.....	24
7.6.2	Angle Shear Connectors.....	24
7.7	Test Verification.....	24

8.0	Quality Assurance/Quality Control.....	24
8.1	Introduction	24
8.2	Quality Assurance.....	24
8.3	Quality Control	24
Commentary		
C2.0	Loading, Geometry, and Analysis	25
C2.1	Introduction	25
C2.2	Loads.....	25
C2.3	Geometric Configurations.....	25
C2.4	Methods of Analysis	26
C3.0	Design of Members.....	30
C3.1	Introduction	30
C3.2	Material	31
C3.3	Minimum Sizing.....	31
C3.4	Slenderness Ratios	31
C3.5	Properties of Sections.....	31
C3.6	Design Compression.....	31
C3.7	Compression Members: Angles	31
	C3.7.3 Determination of F_a	32
	C3.7.4 Effective Lengths.....	32
	C3.7.4.4 Unsupported Length with Varying Forces	32
C3.8	Compression Members: Symmetrical Lipped Angles	34
C3.9	Compression Members Not Covered in Sections 3.7 and 3.8	34
	C3.9.2 Maximum w/t Ratio	34
	C3.9.3 Effective Widths of Elements in Compression	34
	C3.9.8 Nonsymmetric Cross-Sections.....	34
C3.10	Tension Members.....	36
	C3.10.5 Guys.....	36
C3.12	Axial Compression and Bending	36
C3.13	Axial Tension and Bending	36
C3.14	Beams.....	36
	C3.14.4 I, Channel, and Cruciform Sections	36
	C3.14.6 Singly Symmetric I and T Sections.....	37
	C3.14.7 Other Singly Symmetric Open Sections.....	37
	C3.14.8 Equal Leg Angles	37
C3.15	Design Shear.....	37
	C3.15.1 Beam Webs.....	37
C4.0	Design of Connections.....	37
C4.1	Introduction	37
C4.3	Fasteners	37
	C4.3.2 Bolt Shear Capacity	37
	C4.3.3 Bolt Tension Capacity	38
	C4.3.4 Bolts Subject to Combined Shear and Tension.....	38
C4.4	Design Bearing Stress.....	38
C4.5	Minimum Distances	38
	C4.5.1 End Distance.....	38
	C4.5.2 Center-to-Center Bolt Hole Spacing.....	41

	C4.5.3	Edge Distance	41
C4.6		Attachment Holes	41
C6.0		Testing	42
	C6.1	Introduction	42
	C6.2	Foundations	43
		C6.2.1 General	43
		C6.2.2 Rigid Structures	43
		C6.2.3 Direct Embedded Structures	43
		C6.2.3.1 Embedded Portion	43
		C6.2.3.2 Above-Ground Portion	43
		C6.2.4 Components	43
	C6.3	Material	43
	C6.4	Fabrication	43
	C6.5	Strain Measurements	43
	C6.6	Assembly and Erection	44
	C6.8	Load Application	44
	C6.9	Loading Procedures	44
	C6.10	Load Measurement	45
	C6.11	Deflections	45
	C6.13	Disposition of Prototype	45
C7.0		Structural Members and Connections Used in Foundations	45
	C7.1	Introduction	45
	C7.2	General Considerations	45
		C7.2.2 Pressed Plates	45
	C7.3	Deterioration Considerations	45
	C7.5	Design Requirements for Concrete and Reinforcing Steel	45
	C7.6	Shear Connectors	46
		C7.6.1 Stud Shear Connectors	46
		C7.6.2 Angle Shear Connectors	46
8.0		Quality Assurance/Quality Control	46
	C8.1	Introduction	46
	C8.2	Quality Assurance	47
	C8.3	Quality Control	47
References			48
Appendix A—Notation			50
Appendix B—Examples			52
	Example 1	Equal Leg Angle with Symmetrical Bracing	52
	Example 2	Effect of End Connections on Member Capacity	53
	Example 3	Concentric Loading, Two Angle Member	54
	Example 4	K-Bracing, Two Angle Member	54
	Example 5	Effect of Subdivided Panels and End Connections	56
	Example 6	Concentric Loading, Two Angle Member, Subdivided Panels	57
	Example 7	X-Brace Systems with No Intermediate Redundant Support	58
	Example 8	X-Brace Systems with Intermediate Redundant Support—Case 1	59
	Example 9	X-Brace Systems with Intermediate Redundant Support—Case 2	60

Example 10	Cold-Formed Angle.....	61
Example 11	Colded-Formed Lipped Angle.....	62
Example 12	M-Section as Column Member.....	63
Example 13	Channel as Column.....	64
Example 14	T-Section as Column.....	65
Example 15	Schifflerized Angle with Symmetrical Bracing.....	67
Example 16	Schifflerized Angle with Unsymmetrical Bracing.....	68
Index		70

Design of Latticed Steel Transmission Structures

1.0 GENERAL

1.1 SCOPE

Design of Latticed Steel Transmission Structures specifies requirements for the design, fabrication, and testing of members and connections for electrical transmission structures. These requirements are applicable to hot-rolled and cold-formed steel shapes. Structure components (members, connections, guys) are selected to resist design-factored loads at stresses approaching yielding, buckling, fracture, or any other limiting condition specified in this Standard.

1.2 APPLICABLE DOCUMENTS

The following standards are referred to in the body of this document.

American Society for Testing and Materials (ASTM) Standards:

A6/A6M REV A-96 *Standard Specification for General Requirements for Rolled Steel Plates, Shapes, Sheet Piling, and Bars for Structural Use.*

A36/A36M REV B-96 *Standard Specifications for Structural Steel.*

A123 REV A-89 *Standard Specification for Zinc (Hot-Dip Galvanized) Coatings on Iron and Steel Products.*

A143-74 *Standard Practice for Safeguarding Against Embrittlement of Hot-Dip Galvanized Structural Steel Products and Procedure for Detecting Embrittlement.*

A153/A153M-95 *Standard Specification for Zinc Coating (Hot-Dip) on Iron and Steel Hardware.*

A242/A242M REV A-93 *Standard Specification for High-Strength Low-Alloy Structural Steel.*

A394-93 *Standard Specification for Zinc-Coated Steel Transmission Tower Bolts, Zinc-Coated and Bare.*

A529/A529M-94 *Standard Specification for High-Strength Carbon-Manganese Steel of Structural Quality.*

A563-94 *Standard Specification for Carbon and Alloy Steel Nuts.*

A563M-93 *Standard Specification for Carbon and Alloy Steel Nuts (Metric).*

A570/A570M-95 *Standard Specification for Steel, Sheet and Strip, Carbon, Hot-Rolled Structural Quality.*

A572/A572M REV C-94 *Standard Specification for High-Strength Low-Alloy Columbium–Vanadium Structural Steel.*

A588/A588M-94 *Standard Specification for High-Strength Low-Alloy Structural Steel with 50 ksi (345 MPa) Minimum Yield Point to 4 in. (100 mm) Thick.*

A606-96 *Standard Specification for Steel, Sheet and Strip, High-Strength Low-Alloy Hot-Rolled and Cold-Rolled, with Improved Atmospheric Corrosion Resistance.*

A607-96 *Standard Specification for Steel, Sheet and Strip, High-Strength Low-Alloy Columbium or Vanadium, or Both, Hot-Rolled and Cold-Rolled.*

A715-96 *Standard Specification for Steel, Sheet and Strip, High-Strength Low-Alloy Hot-Rolled and Cold-Rolled, and Steel Sheet, Cold-Rolled, High-Strength Low-Alloy with Improved Formability.*

American Welding Society Standard:

AWS D1.1-96 *Structural Welding Code Steel.*

1.3 DEFINITIONS

Block shear: a combination of shear and tensile failure through the end connection of a member caused by high bolt forces acting on the material; also called rupture.

Deformed bars: steel bars meeting the requirements of ACI 318 for reinforcing bars.

Design-factored load: unfactored load multiplied by a specified load factor to establish the design load on a structure.

Downthrust: the downward vertical component of the loads on a foundation.

Leg member: a primary member that serves as the main corner support member of a structure; sometimes called a post member.

Line security: criteria established to prevent a progressive (cascade) failure of structures.

Load factor: a multiplier used with the assumed loading condition, or unfactored load, to establish the design-factored load.

Primary members: tension or compression members that carry the loads on the structure to the foundation.

Redundant members: members that reduce the unbraced length of primary members by providing intermediate support.

Shear friction: for anchor bolts with the base assembly resting on concrete, shear is usually transferred from the base assembly to the concrete through bearing of the bolt at the surface forming a concrete wedge; translation of the wedge under the shear force cannot occur without an upward thrust of the wedge on the base assembly; this thrust induces a clamping force, and this mechanism is called shear friction.

Snug-tight: the tightness that exists when all piles in a joint are in firm contact. This may be attained by a few impacts of an impact wrench or the full effort of a worker using an ordinary spud wrench. In thicker material with multiple plies it may not be possible to achieve continuous firm contact due to variations in thickness and flatness of the facing surface area.

Tension-only member: member with L/r greater than 300, which is assumed to be unable to resist compression.

Unfactored load: load on a structure caused by an assumed loading condition on the wires and/or the structure; the assumed loading condition is usually identified by a combination of wind and/or ice and a temperature condition.

Uplift: the upward vertical component of the loads on a foundation.

2.0 LOADING, GEOMETRY, AND ANALYSIS

2.1 INTRODUCTION

This Standard applies to latticed steel transmission structures. These structures may be either self-supporting or guyed. They consist of hot-rolled or cold-formed prismatic members connected by bolts. Structure components (members, connections, guys) are selected to resist design-factored loads at stresses approaching failure in yielding, buckling, fracture, or any other specified limiting condition.

2.2 LOADS

Design-factored loads shall be determined by the purchaser and shown in the job specification either as load trees or in tabular form. These design loads shall consider:

1. minimum legislated levels;
2. expected climatic conditions;

3. line security provisions; and
4. construction and maintenance operations.

2.3 GEOMETRIC CONFIGURATIONS

Latticed steel structures shall be designed with geometric configurations based on electrical, economic, and safety requirements.

2.4 METHODS OF ANALYSIS

Member forces caused by the design-factored loads shall be determined by established principles of structural analysis.

3.0 DESIGN OF MEMBERS

3.1 INTRODUCTION

The provisions of this section are intended to apply to the design of hot-rolled and cold-formed members.

3.2 MATERIAL

Material conforming to the following standard specifications is suitable for use under this Standard.

ASTM A36. Structural Steel.

ASTM A242. High-Strength Low-Alloy Structural Steel.

ASTM A529. Structural Steel with 42,000 psi Minimum Yield Point.

ASTM A570. Hot-Rolled Carbon Steel Sheet and Strip, Structural Quality.

ASTM A572. High-Strength Low-Alloy Structural Columbium–Vanadium Steels of Structural Quality.

ASTM A588. High-Strength Low-Alloy Structural Steel with 50,000 psi Minimum Yield Point to 4-in. Thick.

ASTM A606. Steel Sheet and Strip, Hot-Rolled and Cold-Rolled, High Strength Low-Alloy, with Improved Corrosion Resistance.

ASTM A607. Steel Sheet and Strip, Hot-Rolled and Cold-Rolled, High Strength Low-Alloy, Columbium or Vanadium, or Both, Hot-Rolled and Cold-Rolled.

ASTM A715. Steel Sheet and Strip, Hot-Rolled, High Strength Low-Alloy, with Improved Formability.

This listing of suitable steels does not exclude the use of other steels that conform to the chemical and mechanical properties of one of the listed specifications or other published specifications, which establish the properties and suitability of the material.

3.3 MINIMUM SIZES

Minimum thicknesses of 1/8 in. (3 mm) for members and 3/16 in. (5 mm) for connection plates are suggested. See Section 7.3 for steel exposed to corrosion at the ground line.

3.4 SLENDERNESS RATIOS

Limiting slenderness ratios for members carrying calculated compressive stress shall be leg members: $L/r \leq 150$; other members: $KL/r \leq 200$. The slenderness ratio KL/r for redundant members shall not exceed 250. The slenderness ratio L/r for tension-only members detailed with draw shall be greater than 300 but less than or equal to 500.

3.5 PROPERTIES OF SECTIONS

Section properties, such as area, moment of inertia, radius of gyration, section modulus, and the like, shall be based on the gross cross-section except where a reduced cross-section or a net cross-section is specified. The reduced cross-section shall consist of all fully effective elements plus those whose widths must be considered reduced in accordance with Section 3.9.3. If all elements are fully effective, the reduced cross-section and the gross cross-section are identical. Net cross-section is defined in Section 3.10.1.

Typical cross-sections are shown in Fig. C3.1 of the Commentary on Section 3. The x - and y -axes are principal axes for all cross-sections shown except the angle, for which the principal axes are u and z , with u being the axis of symmetry for equal leg angles.

Figure 3.1(a) shows the method of determining w/t , the ratio of flat-width to thickness of a member element. For hot-rolled sections, w is the distance from the edge of the fillet to the extreme fiber,

whereas for cold-formed members it is the distance shown in Figure 3.1(b). A larger bend radius can be used in fabrication, but for design purposes w shall be based on a maximum inside-bend radius of two times the element thickness.

3.6 DESIGN COMPRESSION

The design compressive stress F_a on the gross cross-sectional area, or on the reduced area where specified, of axially loaded compression members shall be:

$$F_a = \left[1 - \frac{1}{2} \left(\frac{KL/r}{C_c} \right)^2 \right] F_y \quad \frac{KL}{r} \leq C_c \quad (3.6-1)$$

$$F_a = \frac{\pi^2 E}{\left(\frac{KL}{r} \right)^2} \quad \frac{KL}{r} > C_c \quad (3.6-2)$$

$$C_c = \pi \sqrt{\frac{2E}{F_y}} \quad (3.6-3)$$

where

F_y = minimum guaranteed yield stress;

E = modulus of elasticity;

L = unbraced length;

r = radius of gyration; and

K = effective length coefficient.

3.7 COMPRESSION MEMBERS: ANGLES

The provisions of this section are applicable only for 90° angles. If the angle legs are closed, as in a 60° angle, the provisions of Section 3.9 shall be followed.

3.7.1 Maximum w/t Ratio

The ratio w/t , where w = flat width and t = thickness of leg, shall not exceed 25; see Figure 3.1.

3.7.2 Design Compressive Stress

The design compressive stress on the gross cross-sectional area shall be the value of F_a according to Section 3.6, provided the largest value of w/t does not exceed the limiting value given by Eq. 3.7-1.

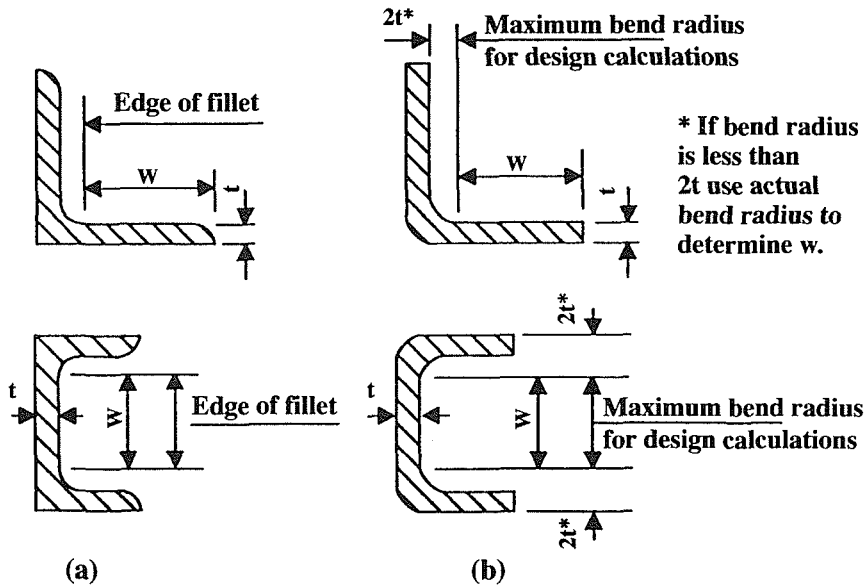

FIGURE 3.1. Determination of w/t Ratios

3.7.3 Determination of F_a

If w/t as defined in Section 3.7.1 exceeds $(w/t)_{lim}$ given by:

$$\left(\frac{w}{t}\right)_{lim} = \frac{80\Psi}{\sqrt{F_y}} \quad (3.7-1)$$

the design stress F_a shall be the value according to Section 3.6 with F_y in Eqs. 3.6-1 and 3.6-3 replaced with F_{cr} given by:

$$F_{cr} = \left[1.677 - 0.677 \frac{w/t}{(w/t)_{lim}} \right] F_y$$

$$\left(\frac{w}{t}\right)_{lim} \leq \frac{w}{t} \leq \frac{144\Psi}{\sqrt{F_y}} \quad (3.7-2)$$

$$F_{cr} = \frac{0.0332\pi^2 E}{(w/t)^2} \quad \frac{w}{t} > \frac{144\Psi}{\sqrt{F_y}} \quad (3.7-3)$$

For Eqs. 3.7-1 through 3.7-3, $\Psi = 1$ for F_y in ksi and 2.62 for F_y in MPa.

3.7.4 Effective Lengths

The effective length KL of members shall be determined in the following sections.

3.7.4.1 Leg Members

For leg members bolted in both faces at connections:

$$\frac{KL}{r} = \frac{L}{r} \quad 0 \leq \frac{L}{r} \leq 150 \quad (3.7-4)$$

For leg members of equal leg angles, having no change in member load between panels, used with staggered bracing, the controlling L/r values shall be as shown in Figure 3.2.

3.7.4.2 Other Compression Members

For members with a concentric load at both ends of the unsupported panel:

$$\frac{KL}{r} = \frac{L}{r} \quad 0 \leq \frac{L}{r} \leq 120 \quad (3.7-5)$$

For members with a concentric load at one end and normal framing eccentricity at the other end of the unsupported panel:

$$\frac{KL}{r} = 30 + 0.75 \frac{L}{r} \quad 0 \leq \frac{L}{r} \leq 120 \quad (3.7-6)$$

For members with normal framing eccentricities at both ends of the unsupported panel:

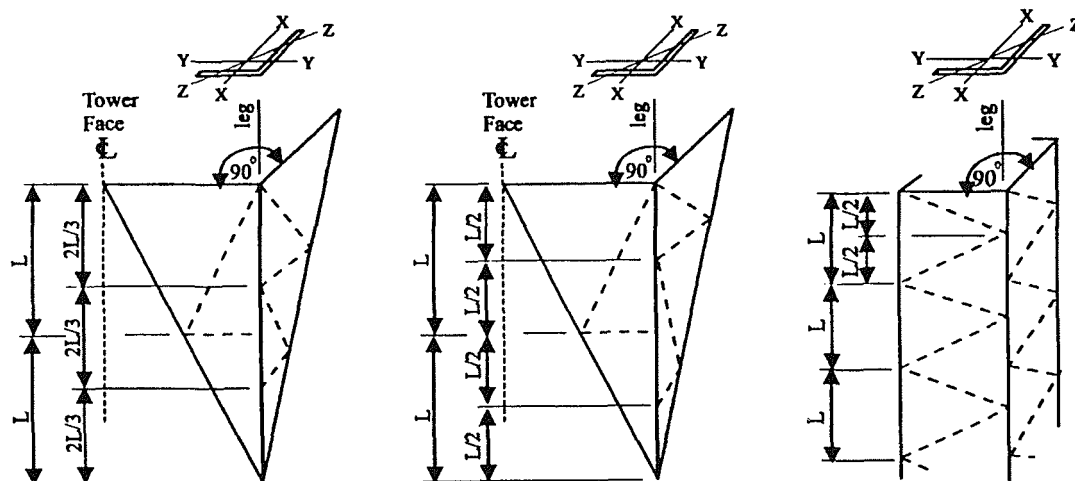

(a) Leg Controlled by $(2/3L)/r_{zz}$

Leg members shall be supported in both faces at the same elevation every four panels

(b) Leg Controlled by $(1.2L)/r_{xx}$

Leg members shall be supported in both faces at the same elevation every four panels

(c) Leg Controlled by $(1.2L)/r_{xx}$

For these configurations some rolling of the leg will occur. Eccentricities at leg splices shall be minimized. The thicker leg sections shall be properly butt-spliced. The controlling L/r values shown shall be used with $K = 1$ as specified by Eq. 3.7-4

FIGURE 3.2. Equal Leg Angle with Staggering Bracing

$$\frac{KL}{r} = 60 + 0.5 \frac{L}{r} \quad 0 \leq \frac{L}{r} \leq 120 \quad (3.7-7)$$

For members unrestrained against rotation at both ends of the unsupported panel:

$$\frac{KL}{r} = \frac{L}{r} \quad 120 \leq \frac{L}{r} \leq 200 \quad (3.7-8)$$

For members partially restrained against rotation at one end of the unsupported panel:

$$\frac{KL}{r} = 28.6 + 0.762 \frac{L}{r} \quad 120 \leq \frac{L}{r} \leq 225 \quad (3.7-9)$$

For members partially restrained against rotation at both ends of the unsupported panel:

$$\frac{KL}{r} = 46.2 + 0.615 \frac{L}{r} \quad 120 \leq \frac{L}{r} \leq 250 \quad (3.7-10)$$

3.7.4.3 Redundant Members

$$\frac{KL}{r} = \frac{L}{r} \quad 0 \leq \frac{L}{r} \leq 120 \quad (3.7-11)$$

If members are unrestrained against rotation at both ends of the unsupported panel:

$$\frac{KL}{r} = \frac{L}{r} \quad 120 \leq \frac{L}{r} \leq 250 \quad (3.7-12)$$

If members are partially restrained against rotation at one end of the unsupported panel:

$$\frac{KL}{r} = 28.6 + 0.762 \frac{L}{r} \quad 120 \leq \frac{L}{r} \leq 290 \quad (3.7-13)$$

If members are partially restrained against rotation at both ends of the unsupported panel:

$$\frac{KL}{r} = 46.2 + 0.615 \frac{L}{r} \quad 120 \leq \frac{L}{r} \leq 330 \quad (3.7-14)$$

3.7.4.4 Unsupported Length with Varying Forces

When the magnitude of the force in a member (P_1 and P_2) changes over the unsupported length (L) of equal subpanels of a truss that is not braced normal to the plane of the truss, the effective length factor (K') for buckling perpendicular to the plane of the truss shall be determined as:

$$K' = 0.75 + 0.25(P_2/P_1), \quad \text{where } P_1 > P_2$$

and both are compression forces, (3.7-15a)

or

$$K' = 0.75 - 0.25(P_2/P_1), \quad \text{where } P_1 = \text{compression}$$

force and $P_2 = \text{tension force.}$ (3.7-15b)

The effect of partial joint restraint is accounted for by Eqs. 3.7-15a and b. Additional adjustment may be required for eccentric loading (as a result of normal framing eccentricities) using Eqs. 3.7-6 and 3.7-7, where $KL/r = K(K'L)/r$.

When out-of-plane support is provided and the load in the member (P_1 and P_2) changes over the supported length (L) each subpanel of the member shall be designed as an individual member with due consideration of any eccentricities when selecting the value of KL/r .

3.7.4.5 Joint Restraint

A single bolt connection at either the end of a member or a point of intermediate support shall not be considered as furnishing restraint against rotation. A multiple bolt connection, detailed to minimize eccentricity, shall be considered to offer partial restraint if the connection is to a member capable of resisting rotation of the joint. A multiple bolt connection to an angle leg or angle chord member, detailed to minimize eccentricity, shall not be considered to offer partial restraint if the connection is made only on a gusset plate without also being framed to the restraining member.

3.7.4.6 Test Verification

Where tests and/or analysis demonstrate that specific details provide restraint different from the recommendations of this section, the values of KL/r specified in this section may be modified.

3.8 COMPRESSION MEMBERS: SYMMETRICAL LIPPED ANGLES

3.8.1 Maximum w/t Ratio

The ratio w/t of the leg shall not exceed 60; see Figure 3.1.

3.8.2 Design Compressive Stress

The design compressive stress on the gross cross-sectional area shall be the value of F_a according to Section 3.6, provided the width-to-thickness ratio of the leg $w/t \leq 220\Psi/\sqrt{F_y}$, where $\Psi = 1$ for F_y in ksi and 2.62 for F_y in MPa. If w/t exceeds $220\Psi/\sqrt{F_y}$, the design shall be based on a reduced area according to Sections 3.5 and 3.9.3.1.b.

3.8.3 Equivalent Radius of Gyration

The design compressive stress defined in Section 3.8.2 shall be computed for the larger of KL/r_z and KL/r_{yf} , where r_{yf} is an equivalent radius of gyration given by:

$$\frac{2}{r_{yf}^2} = \frac{1}{r_t^2} + \frac{1}{r_u^2} + \sqrt{\left(\frac{1}{r_t^2} - \frac{1}{r_u^2}\right)^2 + 4\left(\frac{u_o}{r_t r_u r_{ps}}\right)^2}$$

(3.8-1)

where

$$r_t = \sqrt{\frac{C_w + 0.04J(K_t L)^2}{I_{ps}}} \quad (3.8-2)$$

- C_w = warping constant;
- J = St. Venant torsion constant;
- K_t = effective length coefficient for warping restraint;
- L = unbraced length of member;
- r_u = radius of gyration about u -axis;
- u_o = distance between shear center and centroid;
- $r_{ps} = \sqrt{I_{ps}/A}$ = polar radius of gyration about shear center;
- $I_{ps} = I_u + I_z + Au_o^2$ = polar moment of inertia about shear center;
- I_u = moment of inertia about u -axis;
- I_z = moment of inertia about z -axis; and
- A = area of cross section.

Values of KL/r_z and KL/r_{yf} shall be determined as defined in accordance with Section 3.7.4, using $K_t = 1$ to compute r_t by Eq. 3.8-2.

3.8.4 Minimum Lip Depth

The minimum depth d of a lip at the angle θ with the leg (Figure 3.3) shall be determined by:

$$d = \frac{2.8t}{(\sin \theta)^{2/3}} \sqrt[6]{\left(\frac{w}{t}\right)^2 - \frac{4000\Psi}{F_y}} \geq \frac{4.8t}{(\sin \theta)^{2/3}} \quad (3.8-3)$$

where

$\Psi = 1$ for F_y in ksi and 6.89 for F_y in MPa;
 w/t = flat-width to thickness ratio of the leg.

The ratio w_s/t of the lip (shown in Figure 3.3) shall not exceed $72\Psi/\sqrt{F_y}$, where $\Psi = 1$ for F_y in ksi and 2.62 for F_y in MPa.

3.9 COMPRESSION MEMBERS NOT COVERED IN SECTIONS 3.7 AND 3.8

3.9.1 Design Compressive Stress

The design compressive stress on the gross cross-sectional area, or on the reduced area defined in Section 3.5 if w/t for any element exceeds the limit in Section 3.9.3.1 for which $b = w$ shall be the value of F_a according to Section 3.6. Radii of gyration used to determine F_a shall be computed for the gross cross-section, and limiting values of w/t and the effective widths of elements defined in Section 3.9.3.1 shall be determined with $f = F_a$.

If a reduced area applies and the force P does not act at the center of gravity of the reduced area, the resulting moment shall be taken into account according to Section 3.12.

3.9.2 Maximum w/t Ratio

The ratio w/t of flat width to thickness shall not exceed 60 for elements supported on both longitudinal edges and 25 for elements supported on only one longitudinal edge; see Figure 3.1.

3.9.3 Effective Widths of Elements in Compression

3.9.3.1 Uniformly Compressed Elements

For Eqs. 3.9-1 through 3.9-6, $\Psi = 1$ for f in ksi and 2.62 for f in MPa.

- (a) The effective width b of an element supported on only one longitudinal edge shall be taken as follows:

$$b = w \quad \frac{w}{t} \leq \frac{72\Psi}{\sqrt{f}} \quad (3.9-1)$$

$$b = \frac{108\Psi}{\sqrt{f}} \left(1 - \frac{24\Psi}{(w/t)\sqrt{f}} \right) t \quad \frac{w}{t} > \frac{72\Psi}{\sqrt{f}} \quad (3.9-2)$$

where f = compressive stress in an element computed for compression members as prescribed in Section 3.9.1 and for members in bending in Section 3.14.1. The effective width shall be taken adjacent to the supported edge.

- (b) The effective width b of an element supported on both longitudinal edges shall be taken as follows:

$$b = w \quad \frac{w}{t} \leq \frac{220\Psi}{\sqrt{f}} \quad (3.9-3)$$

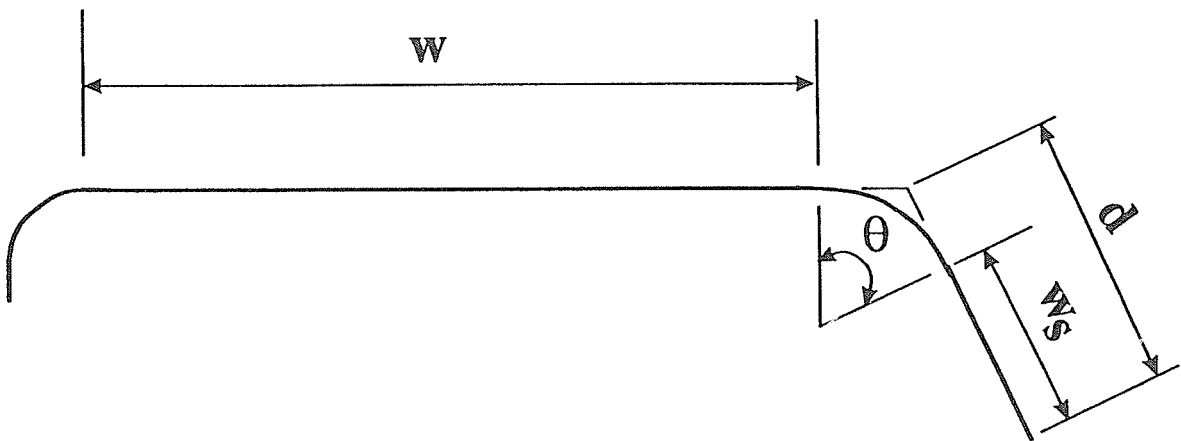

FIGURE 3.3. Minimum Lip Depth

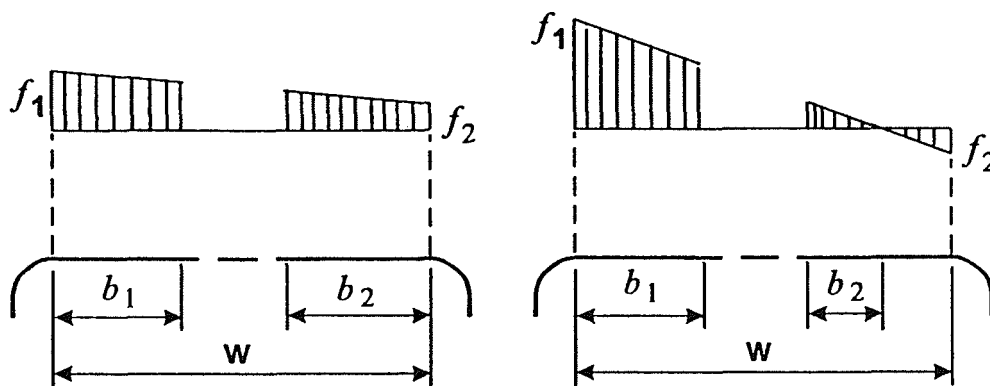

FIGURE 3.4. Elements with Stress Gradient

$$b = \frac{325\Psi}{\sqrt{f}} \left(1 - \frac{71\Psi}{(w/t)\sqrt{f}} \right) t \quad \frac{w}{t} > \frac{220\Psi}{\sqrt{f}} \quad (3.9-4)$$

except that for flanges of square and rectangular sections:

$$b = w \quad \frac{w}{t} \leq \frac{240\Psi}{\sqrt{f}} \quad (3.9-5)$$

$$b = \frac{325\Psi}{\sqrt{f}} \left(1 - \frac{63\Psi}{(w/t)\sqrt{f}} \right) t \quad \frac{w}{t} > \frac{240\Psi}{\sqrt{f}} \quad (3.9-6)$$

where f = compressive stress in an element computed for compression members as prescribed in Section 3.9.1 and for members in bending in Section 3.14.1. The portion of the element considered removed to obtain the effective width shall be taken symmetrically about the centerline.

3.9.3.2 Elements with Stress Gradient

For Eqs. 3.9-7 and 3.9-8, $\Psi = 1$ for f_1 in ksi and 2.62 for f_1 in MPa.

- The effective width b of an element supported on only one longitudinal edge shall be determined as in Section 3.9.3.1.a, using for f the maximum compressive stress in the element.
- The effective widths b_1 and b_2 (Figure 3.4) of an element supported on both longitudinal edges shall be determined as follows:

$$b_2 = \frac{w}{2} \quad \frac{w}{t} \leq \frac{110C\Psi}{\sqrt{f_1}} \quad (3.9-7)$$

$$b_2 = \frac{82C\Psi}{\sqrt{f_1}} \left(1 - \frac{1 - 36C\Psi}{(w/t)\sqrt{f_1}} \right) t \quad \frac{w}{t} > \frac{110C\Psi}{\sqrt{f_1}} \quad (3.9-8)$$

$$b_1 = \frac{b_2}{1.5 - 0.5(f_2/f_1)} \quad (3.9-9)$$

where

$$C = 2 + 0.75[1 - (f_2/f_1)]^2;$$

f_1 = compressive stress shown in Figure 3.4, to be taken positive; and

f_2 = stress shown in Figure 3.4; positive indicates compression, negative indicates tension.

The stresses f_1 and f_2 shall be based on the reduced section, and f_1 shall be the larger if f_2 is compressive. If the sum of the calculated values of b_1 and b_2 exceeds the compressive part of the element, the element is fully effective.

3.9.4 Doubly Symmetric Open Cross-Sections

Members with doubly symmetric open cross-sections (such as a wide flange) whose unsupported length for torsional buckling exceeds the unsupported length for flexural buckling about the weak axis shall be checked for torsional buckling as well as for flexural buckling. The design torsional-buckling stress is the value of F_a according to Section 3.6, using the radius of gyration r_t of Eq. 3.8-2 computed for the gross cross-section.

3.9.5 Singly Symmetric Open Cross-Sections

Members with singly symmetric open cross-sections (such as a 60° angle or channel) shall be checked for flexural buckling in the plane of symmetry and for torsional-flexural buckling. The design torsional-flexural buckling stress is the value of F_a according to Section 3.6, using the radius of gyration r_{tf} of Eq. 3.8-1 computed for the gross cross-section.¹

¹Note that r_x and r_y refer to the principal axes (u , z) of angles.

3.9.6 Point-Symmetric Open Cross-Sections

Members with point-symmetric open cross-sections (such as cruciform) shall be checked for torsional buckling as well as flexural buckling. The design torsional-flexural buckling stress is the value of F_a according to Section 3.6, using the radius of gyration r_t of Eq. 3.8-2, computed for the gross cross-section.

3.9.7 Closed Cross-Sections

Members with closed cross-sections need to be investigated only for flexural buckling.

3.9.8 Nonsymmetric Cross-Sections

The design compressive stress for nonsymmetric shapes shall be determined by tests and/or analysis.

3.9.9 Lips

Element lips shall be dimensioned according to Section 3.8.4.

3.9.10 Eccentric Connections

If the centers of gravity of the member connections cannot be made coincident with the center of gravity of the member cross-section, either gross or reduced as applicable, the resulting bending stresses shall be taken into account according to Section 3.12.

3.10 TENSION MEMBERS

3.10.1 Design Tensile Stress

The design tensile stress F_t on concentrically loaded tension members shall be F_y on the net cross-sectional area A_n , where A_n is the gross cross-sectional area A_g (the sum of the products of the thickness and the gross width of each element as measured normal to the axis of the member) minus the loss due to holes or other openings at the section being investigated. If there is a chain of holes in a diagonal or zigzag line, the net width of an element shall be determined by deducting from the gross width the sum of the diameters of all the holes in the chain and adding for each gauge space in the chain the quantity $s^2/4g$, where s = longitudinal spacing (pitch) and g = transverse spacing (gauge) of any two consecutive holes. The critical net cross-sectional area A_n is obtained from that chain which gives the least net width.

In computing net area for tension, the diameter of a bolt hole that has been punched shall be taken

as 1/16 in. (1.6 mm) greater than the nominal diameter of the hole. For bolt holes that have been drilled or subpunched and reamed, the nominal diameter of the hole may be used.

Plain and lipped angles bolted in both legs at both ends shall be considered to be concentrically loaded.

3.10.2 Angle Members

The design tensile stress F_t on the net area of plain and lipped angles connected by one leg shall be $0.9F_y$. If the legs are unequal and the short leg is connected, the unconnected leg shall be considered to be the same size as the connected leg. If the centroid of the bolt pattern on the connected leg is outside the center of gravity of the angle, the connection shall be checked for rupture (also called block shear) by:

$$P = 0.60A_vF_u + A_tF_y \quad (3.10-1)$$

where

P = design tensile force on connection;
 F_y = specified minimum yield strength of the member;
 F_u = specified minimum tensile strength of the member;
 A_v = minimum net area in shear along a line of transmitted force, see Figure 3.5; and
 A_t = minimum net area in tension from the hole to the toe of the angle perpendicular to the line of force; see Figure 3.5.

In computing net area for tension and net area for shear, the diameter of a bolt hole that has been punched shall be taken as 1/16 in. (1.6 mm) greater than the nominal diameter of the hole. For bolt holes that have been drilled or subpunched and reamed, the nominal diameter of the hole may be used.

3.10.3 Eccentric Connections

Eccentricity of load on angle members is provided for in Section 3.10.2. Other members subjected to both axial tension and bending shall be proportioned according to Section 3.13.

3.10.4 Threaded Rods and Anchor Bolts

Threaded-rod members shall have a minimum guaranteed yield F_y . The design tensile stress F_t on the stress area A_s shall be F_y . A_s is given by:

$$A_s = \frac{\pi}{4} \left(d - \frac{0.974}{n} \right)^2 \quad (3.10-2)$$

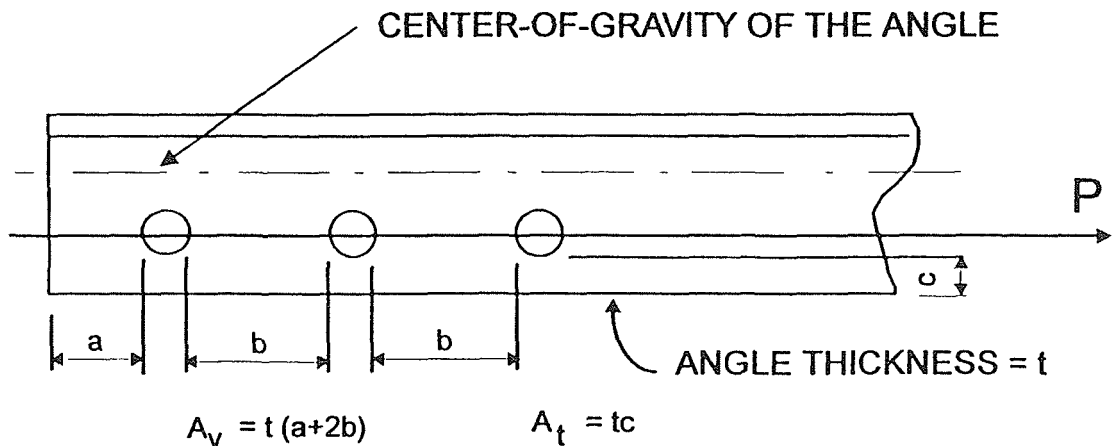

FIGURE 3.5. Rupture (Block Shear) Determination

where

d = nominal diameter; and

n = number of threads per unit of length.

Anchor bolts shall have a minimum guaranteed yield F_y . See Sections 4.3.2 through 4.3.4, and Section 7 for design requirements.

3.10.5 Guys

The design tension in guys shall not exceed 0.65 times the specified minimum breaking strength of the cable.

3.11 STITCH BOLTS

Stitch bolts shall be spaced so that the governing slenderness ratio between bolts for any component of the built-up member does not exceed the following:

For compression members: three-quarters of the governing slenderness ratio of the built-up member.

For tension members: the governing slenderness ratio of the built-up member, or 300.

If the connected leg of a compression member exceeds 4 in. (100 mm), a minimum of two bolts shall be used at each stitch point.

3.12 AXIAL COMPRESSION AND BENDING

Eccentricity of load on angle members is provided for in Sections 3.7.4.2 and 3.8.3. Other members subjected to both axial compression and bending

shall be proportioned to satisfy the following equations.

$$\frac{P}{P_a} + \frac{C_m M_x}{M_{ax}} \left[\frac{1}{1 - P/P_{ex}} \right] + \frac{C_m M_y}{M_{ay}} \left[\frac{1}{1 - P/P_{ey}} \right] \leq 1 \quad (3.12-1)$$

$$\frac{P}{P_y} + \frac{M_x}{M_{ax}} + \frac{M_y}{M_{ay}} \leq 1 \quad (3.12-2)$$

where

C_m = coefficient defined in the following;

P = axial compression;

P_a = design axial compression according to Section 3.9;

P_y = axial compression at yield ($= F_y A$);

$P_{ex} = \pi^2 EI_x / (K_x L_x)^2$;

$P_{ey} = \pi^2 EI_y / (K_y L_y)^2$;

I_x = moment of inertia about the x -axis;

I_y = moment of inertia about the y -axis;

$K_x L_x, K_y L_y$ = effective lengths in the corresponding planes of bending;

M_x, M_y = moments about the x - and y -axes, respectively, at the point or points defined in the following; and

M_{ax}, M_{ay} = corresponding allowable moments according to Section 3.14 computed with $C_b = 1$ if Section 3.14.4 applies.

If there are transverse loads between points of support, M_x and M_y in Eq. 3.12-1 are the maximum moments *between* these points, which in Eq. 3.12-2 are the larger of the moments at these points. If there

are no transverse loads between points of support, M_x and M_y in both Eq. 3.12-1 and Eq. 3.12-2 are the larger of the values of M_x and M_y at these points.

For restrained members with no lateral displacement of one end relative to the other and with no transverse loads in the plane of bending between supports, $C_m = 0.6 - 0.4M_1/M_2$ is positive when bending is in reverse (S) curvature and negative when it is in single curvature. If there are transverse loads between supports, $C_m = 1$ for members with unrestrained ends and 0.85 if the ends are restrained.

3.13 AXIAL TENSION AND BENDING

Eccentricity of load on angle members is provided for in Section 3.10.2. Other members subjected to both axial tension and bending shall be proportioned to satisfy the following formula.

$$\frac{P}{P_a} + \frac{M_x}{M_{ax}} + \frac{M_y}{M_{ay}} \leq 1 \quad (3.13-1)$$

where

P = axial tension;

P_a = design axial tension according to Section 3.10;

M_x, M_y = the moments about the x - and y -axes, respectively; and

M_{ax}, M_{ay} = the corresponding allowable moments according to Section 3.14.

3.14 BEAMS

3.14.1 Properties of Sections

Allowable bending moments shall be determined by multiplying design bending stresses F_b prescribed in the following sections by the section modulus of the gross cross-section or of the reduced section defined in Section 3.5, as applicable. Radii of gyration used to determine the value of F_b for the extreme fiber in compression shall be based on the gross cross-section. Effective widths of section elements shall be determined as prescribed in Section 3.9.3, using for f the stress on the element corresponding to the allowable moment previously defined. Limiting values of w/t shall be those given in Section 3.9.2.

3.14.2 Design Tension

The design bending stress F_b on the extreme fiber in tension shall be F_y .

3.14.3 Laterally Supported Beams

The design bending stress F_b on the extreme fiber in compression for members supported against lateral buckling shall be F_y .

3.14.4 I, Channel, and Cruciform Sections

The design bending stress F_b on the extreme fiber in compression for doubly symmetric I sections, singly symmetric channels, and singly or doubly symmetric cruciform sections in bending about the x -axis (the x -axis is to be taken perpendicular to the web of the I and channel, but may be either principal axis for the cruciform) and not supported against lateral buckling, shall be the value of F_a according to Section 3.6 with $K = \sqrt{K_y K_r}$ and r given by:

$$r^2 = \frac{C_b \sqrt{I_y}}{S_x} \sqrt{C_w + 0.04J(K_r L)^2} \quad (3.14-1)$$

where

K_y = effective-length coefficient for y -axis bending;

K_r = effective-length coefficient for warping restraint;

I_y = moment of inertia about y -axis;

S_x = x -axis section modulus;

C_w = warping constant²;

J = St. Venant torsion constant; and

L = unbraced length.

For members with moments M_1 and M_2 at the ends of the unbraced length:

$$C_b = 1.75 + 1.05M_1/M_2 + 0.3(M_1/M_2)^2 < 2.3 \quad (3.14-2)$$

where M_1 is the smaller end moment and M_1/M_2 is positive when bending is in reverse (S) curvature and negative when it is in single curvature.

For members for which the moment within a significant portion of the unbraced length equals or exceeds the larger of the end moments, and for unbraced cantilevers, $C_b = 1$.

The design stress on the extreme fiber in compression for the I section in bending about the y -axis shall be taken equal to F_y ; for channels, see Section 3.14.7.b.

²For the I section, $C_w = 0.25d^2I_y$. An approximation for the channel is $C_w = 0.15d^2I_y$. for the cruciform section $C_w = 0$. The section depth = d .

3.14.5 Other Doubly Symmetric Open Sections

The design bending stress F_b on the extreme fiber in compression for laterally unsupported members of doubly symmetric open cross-section not covered in Section 3.14.4 shall be the value of F_a according to Section 3.6, determined as follows.

For x -axis bending, follow Section 3.14.4 (Eq. 3.14-1); for y -axis bending, follow Section 3.14.4 (Eq. 3.14-1) but with K_x , I_x , and S_x substituted for K_y , I_y , and S_x , respectively.

3.14.6 Singly Symmetric I and T Sections

The design bending stress F_b on the extreme fiber in compression for singly symmetric I-shaped members with the compression flange larger than the tension flange and for singly symmetric single-web T-shaped members with the flange in compression, in bending about the x -axis (the axis perpendicular to the web), and not supported against lateral buckling, may be taken the same as the value for a section of the same depth with a tension flange the same as the compression flange of the I or the T section. The allowable moment shall be calculated by multiplying the design stress so obtained by the compression flange section modulus of the singly symmetric shape.

The design bending stress on the extreme fiber in compression for the sections previously described, in bending about the y -axis (the axis of symmetry), shall be determined according to Section 3.14.7.a.

3.14.7 Other Singly Symmetric Open Sections

The design bending stress F_b on the extreme fiber in compression for members with singly symmetric open cross-section and not supported against lateral buckling, other than those covered in Sections 3.14.4 and 3.14.6, shall be the value of F_a determined according to Section 3.6 as follows:

- (a) For members in bending about the axis of symmetry (the y -axis is to be taken as the axis of symmetry), use

$$K = \sqrt{K_x K_t}$$

and r from Eq. 3.14-1.

- (b) For members in bending about the x -axis (the axis perpendicular to the axis of symmetry), use $K = K_x$, and r given by:

$$r^2 = \frac{C_b \sqrt{I_y}}{S_{xc}} \left\{ \pm j \sqrt{I_y} + \sqrt{j^2 I_y + \left(\frac{K_y}{K_t} \right)^2 [C_w + 0.04J(K_t L)^2]} \right\} \quad (3.14-3)$$

where

$$j = \left[\frac{1}{2I_x} \int_A (x^2 + y^2)x \, dA \right] - y_o \quad (3.14-4)$$

S_{xc} = section modulus of compression flange about x -axis;

y_o = distance from centroid to shear center;

A = area of cross-section;

I_y = y -axis moment of inertia;

I_x = x -axis moment of inertia; and

K_y = effective-length coefficient for y -axis bending.

C_b , K_t , C_w , J , and L as defined in Eqs. 3.14-1 and 3.14-2.

The positive direction of the y -axis must be taken so that the shear center coordinate y_o is negative. The plus sign for the $j\sqrt{I_y}$ in Eq. 3.14-3 is to be used if the moment causes compression on the shear center side of the x -axis, and the minus sign if it causes tension.

3.14.8 Equal Leg Angles

Provided the eccentricity of the load with respect to the shear center is not more than one-half of the leg width (Figure 3.6), the allowable bending moment for a laterally unsupported equal leg angle may be taken as the smaller of:

- The moment M_y that produces tensile yield stress at the extreme fiber; or
- The moment M_b that causes lateral buckling given by the following:

$$\text{If } M_e \leq 0.5 M_{yc} \quad M_b = M_e \quad (3.14-5)$$

$$\text{If } M_e \geq 0.5 M_{yc} \quad M_b = M_c \left(1 - \frac{M_{yc}}{4M_e} \right) \quad (3.14-6)$$

where

M_{yc} = moment causing compressive yield at extreme fiber; and

M_e = elastic critical moment.

Values of M_e are given by:

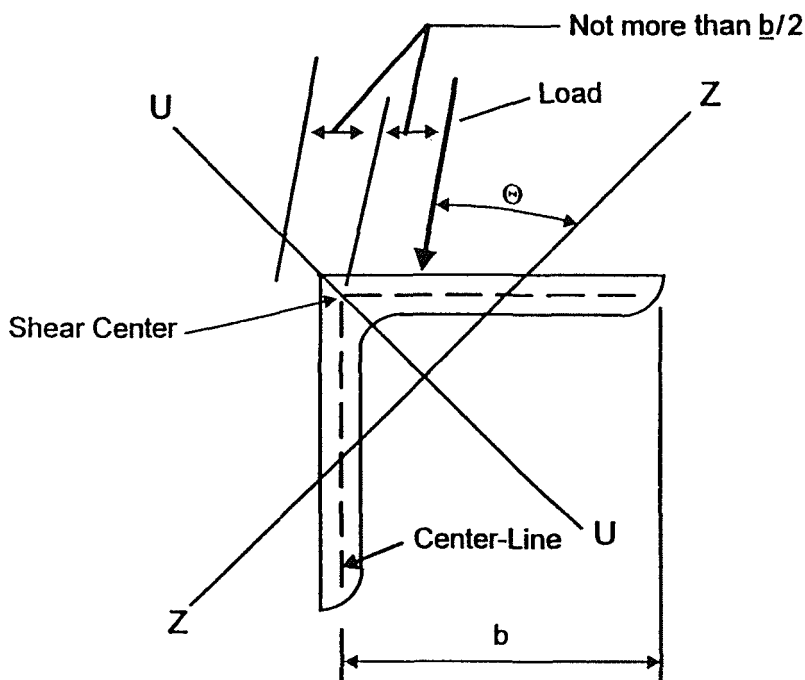

FIGURE 3.6. Load on Angles

For load perpendicular to a leg:

$$M_e = \frac{0.66Eb^4t}{(KL)^2} \left[\sqrt{1 + \frac{0.81(KL)^2t^2}{b^4}} \pm 1 \right] \quad (3.14-7)$$

For load at the angle θ with the z -axis (Figure 3.6):

$$M_e = \frac{233Eb^4t}{(1 + 3 \cos^2\theta)(KL)^2} \times \left[\sqrt{\sin^2\theta + \frac{0.162(1 + 3 \cos^2\theta)(KL)^2t^2}{b^4}} \pm \sin \theta \right] \quad (3.14-8)$$

where

- E = modulus of elasticity;
- F_y = yield stress;
- b = width of leg - $t/2$;
- t = thickness of leg;
- L = unsupported length; and

$K = 1.0$ if the angle is simply supported on the x - and y -axes at each end or 0.5 if it is fixed against rotation about the x - and y -axes at each end.

The plus sign for the last term (± 1) in Eq. 3.14-7 and ($\pm \sin \theta$) in Eq. 3.14-8, applies when the load acts in the direction shown in Figure 3.6 and the minus sign when it acts in the opposite direction.

The yield moments M_{yt} and M_{yc} are given by M_y in the following.

At the heel of the angle:

$$F_y = \pm \frac{M_y \sin \theta}{S_t} \quad (3.14-9)$$

At the toe of the angle:

$$F_y = \pm \frac{M_y \sin \theta}{S_t} + \frac{M_y \cos \theta}{S_u} \quad (3.14-10)$$

where

S_u and S_z = section moduli for the u - and z -axes, respectively.

The plus sign denotes tension and the minus sign compression. The applicable signs are determined ac-

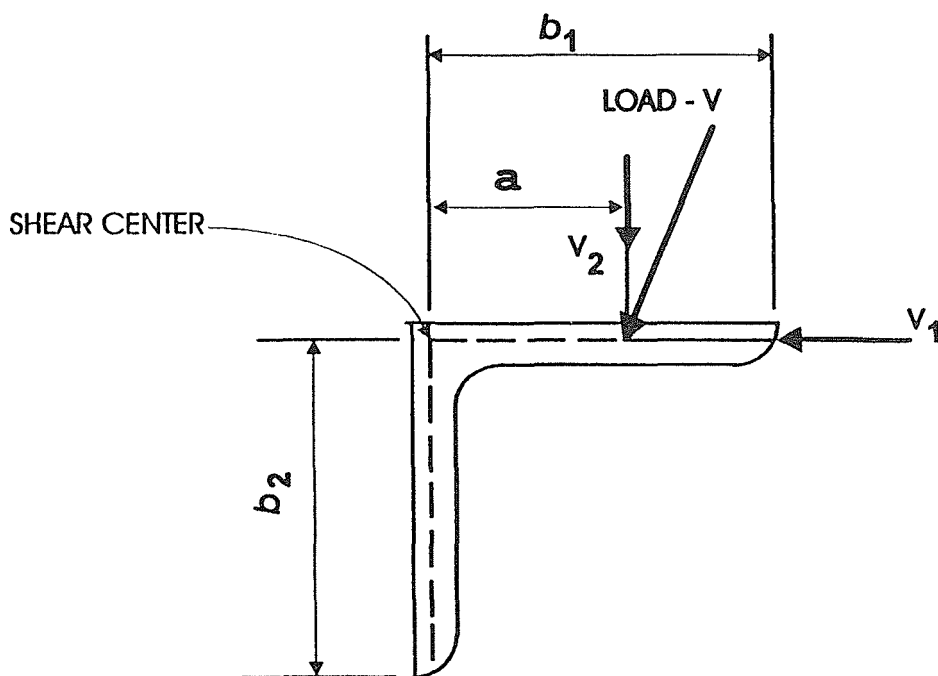

FIGURE 3.7. Shear Load on Angles

according to the type of stress produced at the extreme fiber being checked. The following section moduli based on centerline dimensions may be used in lieu of those based on overall dimensions.

$$S_u = \frac{b^2 t}{1.5\sqrt{2}} \quad S_t = \frac{b^2 t}{3\sqrt{2}} \quad (3.14-11)$$

3.15 DESIGN SHEAR

3.15.1 Beam Webs

For Eqs. 3.15-1 through 3.15-3, $\Psi = 1$ for F_v in ksi and 2.62 for F_v in MPa.

The ratio h/t of the depth of a beam web to its thickness shall not exceed 200. The design average shearing stress F_v on the gross area of a beam web shall not exceed the following:

$$F_v = 0.58F_y \quad \frac{h}{t} \leq \frac{440\Psi}{\sqrt{F_y}} \quad (3.15-1)$$

$$F_v = \frac{255\sqrt{F_y}}{\Psi(h/t)} \quad \frac{440\Psi}{\sqrt{F_y}} \leq \frac{h}{t} \leq \frac{557\Psi}{\sqrt{F_y}} \quad (3.15-2)$$

$$F_v = \frac{0.5\pi^2 E}{(h/t)^2} \quad \frac{h}{t} > \frac{557\Psi}{\sqrt{F_y}} \quad (3.15-3)$$

where F_y = yield stress.

3.15.2 Angles

The shear components V_1 and V_2 of the applied shear V on single-angle beams (Figure 3.7) shall satisfy the following equations.

$$\frac{3V_1}{2b_1 t} + \frac{V_2 a t}{J} \leq 0.58F_y \quad (3.15-4)$$

$$V_2 \left(\frac{3}{2b_2 t} + \frac{a t}{J} \right) \leq 0.58F_y \quad (3.15-5)$$

where

V_1 = component of V in leg b_1 ;

V_2 = component of V in leg b_2 ;

a = distance of shear center to intersection of load plane with leg b_1 ;

b_1, b_2 = width of leg - $t/2$;

t = thickness of leg;

J = St. Venant torsional constant $= (b_1 + b_2)t^3/3$;
and

F_y = yield stress.

3.16 TEST VERIFICATION

Design values other than those prescribed in this Section may be used if substantiated by experimental or analytical investigations.

4.0 DESIGN OF CONNECTIONS

4.1 INTRODUCTION

Bolted connections for transmission structures are normally designed as bearing type connections. It is assumed that bolts connecting one member to another carry the load in the connection equally.

The minimum end and edge distances determined by the provisions of this chapter do not include an allowance for fabrication and rolling tolerances. Unless otherwise noted, these provisions pertain to standard holes, that is, holes nominally 1/16 in. (1.6 mm) larger than the bolt diameter.

4.2 GENERAL REQUIREMENTS

The Engineer of Record (EOR) shall approve the shop detail drawings; see Section 5.1.2.

4.3 FASTENERS

4.3.1 Materials

The commonly used fastener specifications for latticed steel transmission towers are ASTM A394 for bolts and A563 for nuts.

4.3.2 Bolt Shear Capacity

Design shear for A394 bolts shall be the shear strength tabulated in the ASTM specification.

For bolts that do not have an ASTM-specified shear strength the design shear stress F_v on the effective area shall be $0.62F_u$, where F_u is the specified minimum tensile strength of the bolt material. The effective area is the gross cross-sectional area of the bolt if threads are excluded from the shear plane or the root area if threads are in the shear plane.

4.3.3 Bolt Tension Capacity

Bolts shall be proportioned so that the sum of the tensile stresses caused by the applied external load and any tensile stress resulting from prying action does not exceed the design tensile stress F_t , as follows:

- (a) For bolts having a specified proof-load stress, F_t = ASTM proof-load stress by the length-measurement method.
- (b) For bolts with no specified proof-load stress, F_t = $0.6F_u$.

The stress area A_s is given by:

$$A_s = \frac{\pi}{4} \left(d - \frac{0.974}{n} \right)^2 \quad (4.3-1)$$

where

d = nominal diameter of the bolt; and
 n = number of threads per unit of length.

4.3.4 Bolts Subject to Combined Shear and Tension

For bolts subject to combined shear and tension the design tensile stress $F_t(v)$ shall be:

$$F_t(v) = F_t [1 - (f_v/F_v)^2]^{1/2} \quad (4.3-2)$$

where

F_t = design tensile stress defined in Section 4.3.3;
 F_v = design shear stress defined in Section 4.3.2; and
 f_v = computed shear stress on effective area.

The combined tensile and shear stresses shall be taken at the same cross-section in the bolt.

4.4 DESIGN BEARING STRESS

The maximum bearing stress, calculated as the force on a bolt divided by the product of the bolt diameter times the thickness of the connected part, shall not exceed 1.5 times the specified minimum tensile strength F_u of the connected part or the bolt.

4.5 MINIMUM DISTANCES

4.5.1 End Distance (See Figure C4.2)

For stressed members, the distance e measured from the center of a hole to the end, whether this end is perpendicular or inclined to the line of force, shall not be less than the value of e_{\min} , determined as the

largest value of e from Eqs. 4.5-1 through 4.5-3:

$$e = 1.2P/F_u t \quad (4.5-1)$$

$$e = 1.3d \quad (4.5-2)$$

$$e = t + d/2 \quad (4.5-3)$$

where

F_u = specified minimum tensile strength of the connected part;

t = thickness of the connected part;

d = nominal diameter of bolt; and

P = force transmitted by the bolt.

For redundant members, e_{\min} shall be determined as the larger value of e from Eqs. 4.5-3 and 4.5-4:

$$e = 1.2d \quad (4.5-4)$$

Equation 4.5-3 does not apply for either stressed members or redundant members if the holes are drilled.

4.5.2 Center-to-Center Bolt Hole Spacing

Along a line of transmitted force, the distances between centers of holes shall not be less than the value of s_{\min} determined as:

$$s_{\min} = 1.2P/F_u t + 0.6d \quad (4.5-5)$$

4.5.3 Edge Distance (See Figure C4.2)

The distance f from the center of a hole to the edge of the member shall not be less than the value of f_{\min} given by the following.

For a rolled edge:

$$f_{\min} = 0.85e_{\min} \quad (4.5-6)$$

For a sheared or mechanically guided flame cut edge:

$$f_{\min} = 0.85e_{\min} + 0.0625\Psi \quad (4.5-7)$$

where

e_{\min} = end distance according to Section 4.5.1; and

$\Psi = 1$ for f_{\min} in in. and 25.4 for f_{\min} in mm.

4.6 ATTACHMENT HOLES

This section is valid for hole diameter to bolt diameter ratios ≤ 2 . The force P for a bolt in an attachment hole shall be limited by:

$$P \leq 0.75(L - 0.5d_h)tF_u \quad (4.6-1)$$

or

$$P \leq 135dtF_u \quad (4.6-2)$$

where

L = minimum distance from the center of the hole to any member edge;

d = nominal diameter of bolt;

d_h = attachment hole diameter;

t = member thickness; and

F_u = specified minimum tensile strength of the member.

4.7 TEST VERIFICATION

Design values other than those prescribed in this section may be used if substantiated by experimental or analytical investigations.

5.0 DETAILING AND FABRICATION

5.1 DETAILING

5.1.1 Drawings

Tower detail drawings consist of erection drawings, shop detail drawings, and bills of material. Erection drawings shall show the complete assembly of the structure indicating clearly the positioning of the members. Each member shall be piece-marked and the number and lengths of bolts shall be given for each connection. Shop detail drawings shall be shown either by assembled section (in place) or piece by piece (knocked down), either hand drawn or computer drawn. Layout drawings shall be required when details are not shown by assembled sections. Computer-generated bills of material shall be acceptable unless otherwise specified by the purchaser.

5.1.2 Approval of Shop Drawings

Shop detail drawings shall be approved by the Engineer of Record (EOR) regarding compliance with the purchaser's specifications and the strength requirements of the design. The EOR shall be the utility structural engineer, a consulting structural engineer, or the fabricator's structural engineer, depending on who generated the structural tower design. The EOR's review and approval of the shop detail

drawings include responsibility for the strength of connections but do not pertain to the correctness of dimensional detail calculations, which is the responsibility of the detailer. They also do not imply approval of means, methods, techniques, sequences, or procedures of construction, or of safety precautions and programs.

5.1.3 Connections

Usual detailing practice is to connect members directly to each other with minimum eccentricity. If specific joint details are required by the EOR they shall be shown on the design drawings as referenced in the contract documents.

5.1.4 Bolt Spacing

Minimum bolt spacing, and end and edge distances, as specified in the design sections of this document, shall not be underrun by mill or standard fabrication tolerances. The purchaser's specifications shall state if end distances, edge distances, and center-to-center hole spacing dimensions include provisions for mill and fabrication tolerances; if they do not, dimensions used for detailing must be adjusted to ensure that minimum dimensions are provided in the fabricated member.

5.1.5 Detail Failures During Testing

If a structural failure occurs during testing of a tower, a review shall be made by the EOR to determine the reasons and to specify the required revisions.

5.1.6 Material

Detail drawings shall clearly specify member and connection materials, such as ASTM specification and grade designation.

5.1.7 Weathering Steel

If the structure is made of weathering steel, special detailing procedures shall be required; see Brockenbrough (1983) and Brockenbrough and Schmitt (1975).

5.1.8 Tension-Only Members

Tension-only members shall be detailed sufficiently short to provide draw. Draw must consider the length and size of the member. To facilitate erection, these members shall have at least two bolts on one end. Members 15 ft (4.6 m) in length, or less, are detailed 1/8 in. (3.2 mm) short. Members more than 15 ft (4.6 m) long are detailed 1/8 in. (3.2 mm)

short, plus 1/16 in. (1.6 mm) for each additional 10 ft (3.1 m) or fraction thereof. If such members are spliced, the draw shall provide for the slippage at the splice.

5.1.9 Shop Check Assembly

The purchaser's specifications shall include a requirement for shop assembly of new tower details, to be done partially by sections and in the horizontal position. This helps validate detailing calculations and dimensions, minimize fit-up conflicts, and assure proper assembly in the field.

5.1.10 Other Considerations

All dimensions on detail drawings shall be shown with dimensional accuracy to the nearest 1/16 in. (1.6 mm).

Welded connections and built-up components shall require seal welds. Closed sections shall be detailed with vent or drain holes if they are to be galvanized. Caution shall be used to avoid explosive effects, which can injure workers or damage the component during the galvanizing process.

5.2 FABRICATION

5.2.1 Material

Since various steels are used in transmission towers, a quality control program, as specified in this Standard, is necessary. A36 steel is considered the basic steel. All other steels shall have a special marking starting at the mill, be inventoried separately at the fabrication plant, and be properly identified during the fabricating process. Mill test reports shall be considered sufficient as certification of material, unless the purchaser's specification calls for other requirements.

5.2.2 Specifications

Fabrication shall be performed according to the purchaser's specification. If this specification does not cover fabrication procedures, the latest edition of the AISC Specification or a specification applicable to transmission towers shall be used. These documents provide a description of acceptable fabrication methods and procedures.

5.2.3 Shop Operations

Shop operations consist essentially of cutting (sawing, shearing, or flame cutting), punching, drilling, blocking, or clipping, and either cold or hot

bending. Hot bending will require steel to be heated to 1400–1600°F (760–871°C) if the steel is not produced to fine grain practice; see *The Making, Shaping and Treating of Steel* (AISE 1985).

Cold bending is normally done on pieces with simple bends at small bevels. Hot bending is necessary on pieces with moderate bevels and/or compound bends; heating shall be done evenly and shall be of sufficient length and temperature to minimize necking down of the section at the bend line. Pieces requiring bends at several bevels may have to be cut, formed, and welded. Specific preparation instructions and welding symbols shall be shown on the shop detail drawings in this case.

The actual position of any punched or drilled hole on a member shall not vary more than $1/32$ in. (0.8 mm) from the position for that hole shown on the shop detail drawing.

The purchaser shall review fabricators' quality control procedures and agree on methods before fabrication begins. If there is disagreement, this shall be settled in writing prior to fabrication.

5.2.4 Piece Marks

Each tower member shall have a number conforming to the piece mark on the erection drawings stamped with a metal die. For galvanized material these marks shall be stamped prior to galvanizing. Marks shall be minimum of $1/2$ in. (12.7 mm) high. For special pieces, such as anchor bolts, where die stamping is not feasible, an indelible ink marking or special tagging which is durable and waterproof may be used. Some purchasers require that higher strength steel members include a suffix, such as "H" or "X," on the piece mark.

5.2.5 Welding

Welding procedures shall comply with ANSI/AWS D1.1. Special care shall be taken regarding seal welds to assure proper galvanizing and to avoid acid "bleeding" at pockets in structural assemblies.

5.2.6 Galvanizing

Galvanizing shall be in accordance with ASTM A-123 and A-153. Procedures to avoid material embrittlement are given in ASTM A-143.

5.2.7 Shipping

The purchaser's specification shall clearly state the packing, bundling methods, and shipping procedures required.

6.0 TESTING

6.1 INTRODUCTION

The purchaser shall specify in the contract documents which structures or components of structures will be tested. If a proof test of a structure or a component of a structure is specified, the test shall be performed on a full-size prototype of the structure or component in accordance with the following sections.

6.2 FOUNDATIONS

Tests shall be performed with the prototype attached to reaction points that have the same strengths and freedoms of movement as the reaction points that will be present in the structure in service. The EOR shall specify the anchorage requirements, including acceptable tolerances, in the contract documents.

6.3 MATERIAL

The prototype shall be made of material that is representative of the material that will be used in the production run. Mill test reports or coupon tests shall be available for all important members in the prototype including, as a minimum, the members designed for only tension loading, and compression members with KL/r less than 120.

6.4 FABRICATION

Fabrication of the prototype shall be done in the same manner as for the production run.

6.5 STRAIN MEASUREMENTS

The purchaser shall specify if any special strain measurement determination methods are required for the prototype being tested.

6.6 ASSEMBLY AND ERECTION

The method of assembly of the prototype shall be specified by the purchaser. If tight bolting of sub-assemblies is not permitted by the construction speci-

fications, the prototype shall be assembled and erected with all bolts finger-tight only, and tightening to final torque shall be done after all members are in place. Pickup points that are designed into the structure shall be used during erection as part of the test procedure.

6.7 TEST LOADS

The design-factored loads (see Section 2.2) shall be applied to the prototype in accordance with the load cases specified. The test specification shall state if the structure is to be tested to destruction. Wind-on-structure loads shall be applied as concentrated loads at selected points on the prototype. These loads shall be applied at panel points where stressed members intersect so the loads can be resisted by the main structural system. The magnitudes and points of application of all loads shall be designated by the responsible engineer and approved by the purchaser.

6.8 LOAD APPLICATION

Load lines shall be attached to the load points on the prototype in a manner that simulates the in-service application as closely as possible. The attachment hardware for the test shall have the same degrees of freedom as the in-service hardware.

6.9 LOADING PROCEDURE

The number and sequence of load cases tested shall be specified by the responsible engineer and approved by the purchaser.

Loads shall be applied to 50, 75, 90, 95, and 100% of the design-factored loads. After each increment is applied, there shall be a "hold" to allow time for reading deflections and to permit the engineers observing the test to check for signs of structural distress. The 100% load for each load case shall be held for 5 minutes.

Loads shall be removed completely between load cases except for noncritical load cases where, with the responsible engineer's permission, the loads may be adjusted as required for the next load case. Unloading shall be controlled to avoid overstressing any members.

6.10 LOAD MEASUREMENT

All applied loads shall be measured at the point of attachment to the prototype. Loads shall be measured through a verifiable arrangement of strain devices or by predetermined dead weights. Load-measuring devices shall be used in accordance with manufacturer's recommendations and calibrated prior to and after the conclusion of testing.

6.11 DEFLECTIONS

Structure deflections under load shall be measured and recorded as specified by the responsible engineer. Deflection readings shall be made for the before- and off-load conditions, as well as at all intermediate holds during loading.

All deflections shall be referenced to common base readings taken before the first test loads are applied.

6.12 FAILURES

When a premature structural failure occurs, the cause of the failure, the corrective measures to be taken, and the need for a retest shall be determined by the EOR and approved by the purchaser.

If a retest is ordered, failed members and members affected by consequential damage shall be replaced. The load case that caused the failure shall be repeated. Load cases previously completed need not be repeated.

After completion of testing, the prototype shall be dismantled and all members inspected. The following shall not be considered as failures.

- (a) Residual bowing of members designed for only tension;
- (b) Ovalization of no more than one-half the holes in a connection; and
- (c) Slight deformation of no more than one-half the bolts in a connection.

6.13 DISPOSITION OF PROTOTYPE

The test specification shall state what use may be made of the prototype after the test is completed.

6.14 REPORT

The testing organization shall furnish the number of copies required by the job specifications of a test report that shall include:

- (a) The designation and description of the prototype tested;
- (b) The name of the purchaser;
- (c) The name of the person or organization (responsible engineer) that specified the loading, electrical clearances, technical requirements, and general arrangement of the prototype;
- (d) The name of the Engineer of Record;
- (e) The name of the fabricator;
- (f) A brief description and the location of the test frame;
- (g) The names and affiliations of the test witnesses;
- (h) The dates of each test load case;
- (i) Design and detail drawings of the prototype, including any changes made during the testing program;
- (j) A rigging diagram with details of the points of attachment to the prototype;
- (k) Calibration records of the load-measuring devices;
- (l) A loading diagram for each load case tested;
- (m) A tabulation of deflections for each load case tested;
- (n) In case of failure:
 - Photographs of failure;
 - Loads at the time of failure;
 - A brief description of the failure;
 - Remedial actions taken;

- Dimensions of the failed members; and
- Test coupon reports of failed members;
- (o) Photographs of the overall testing arrangement and rigging;
- (p) Air temperature, wind speed and direction, any precipitation, and any other pertinent meteorological data;
- (q) Mill test reports as submitted according to the requirements of Section 6.3; and
- (r) Additional information specified by the purchaser.

7.0 STRUCTURAL MEMBERS AND CONNECTIONS USED IN FOUNDATIONS

7.1 INTRODUCTION

This section specifies design procedures for steel members and connections embedded in concrete foundations or the earth. Additional requirements for structural members and connections of grillages, pressed plates, anchor bolts, and stub angles are covered in Sections 3 and 4. Figure 7.1 illustrates some typical foundations.

7.2 GENERAL CONSIDERATIONS

7.2.1 Steel Grillages

The members forming the pyramid, Figure 7.1(a), shall be designed considering no lateral sup-

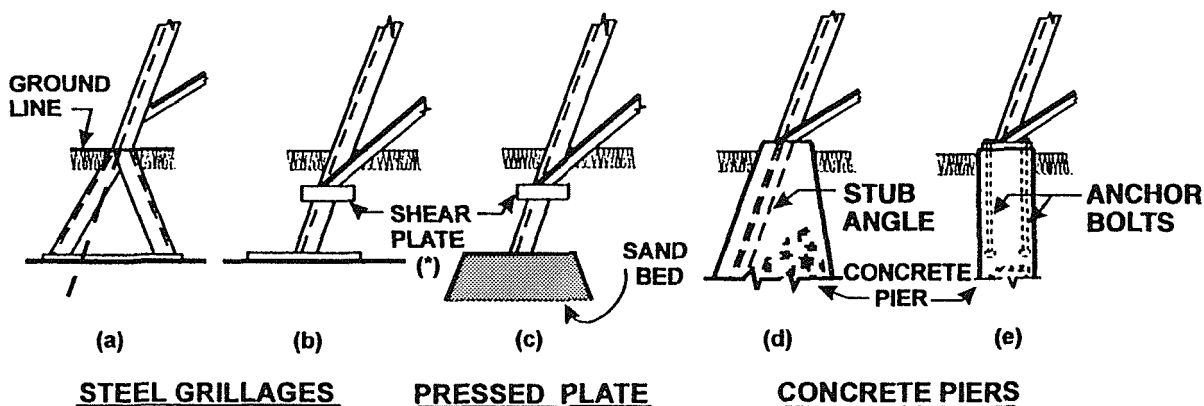

(*) CHANNEL OR ANGLE ORIENTED AS SHOWN OR PARALLEL TO LEG

FIGURE 7.1. Typical Foundations

port from the surrounding soil. The stub angle, or leg member, Figure 7.1(b), shall be designed considering support only at the shear plate and the base of the grillage.

7.2.2 Pressed Plates

The stub angle, or leg member, Figure 7.1(c), shall be designed considering support only at the pressed plate base and the shear plate.

7.2.3 Stub Angles

The tensile and compressive loads in the stub angle, Figure 7.1(d), shall be transferred to the concrete by the bottom plate or the shear connectors shown in Figure 7.2. The shear load shall be transferred to the concrete by side bearing pressure.

7.2.4 Anchor Bolts (See Figure 7.1(e))

7.2.4.1 Smooth Bars with Base Assembly in Contact with Concrete or Grout

The anchor bolt shall be designed to transfer the tensile load to the concrete by the end connection.

The compressive load shall be transferred to the concrete or grout by the base assembly. The shear load is assumed to be transferred to the concrete by shear friction based upon the clamping force on the base assembly.

7.2.4.2 Deformed Bars with Base Assembly in Contact with Concrete or Grout

The anchor bolt shall be designed with sufficient embedded length to transfer the tensile load to the concrete by bond between the bolt and the concrete.

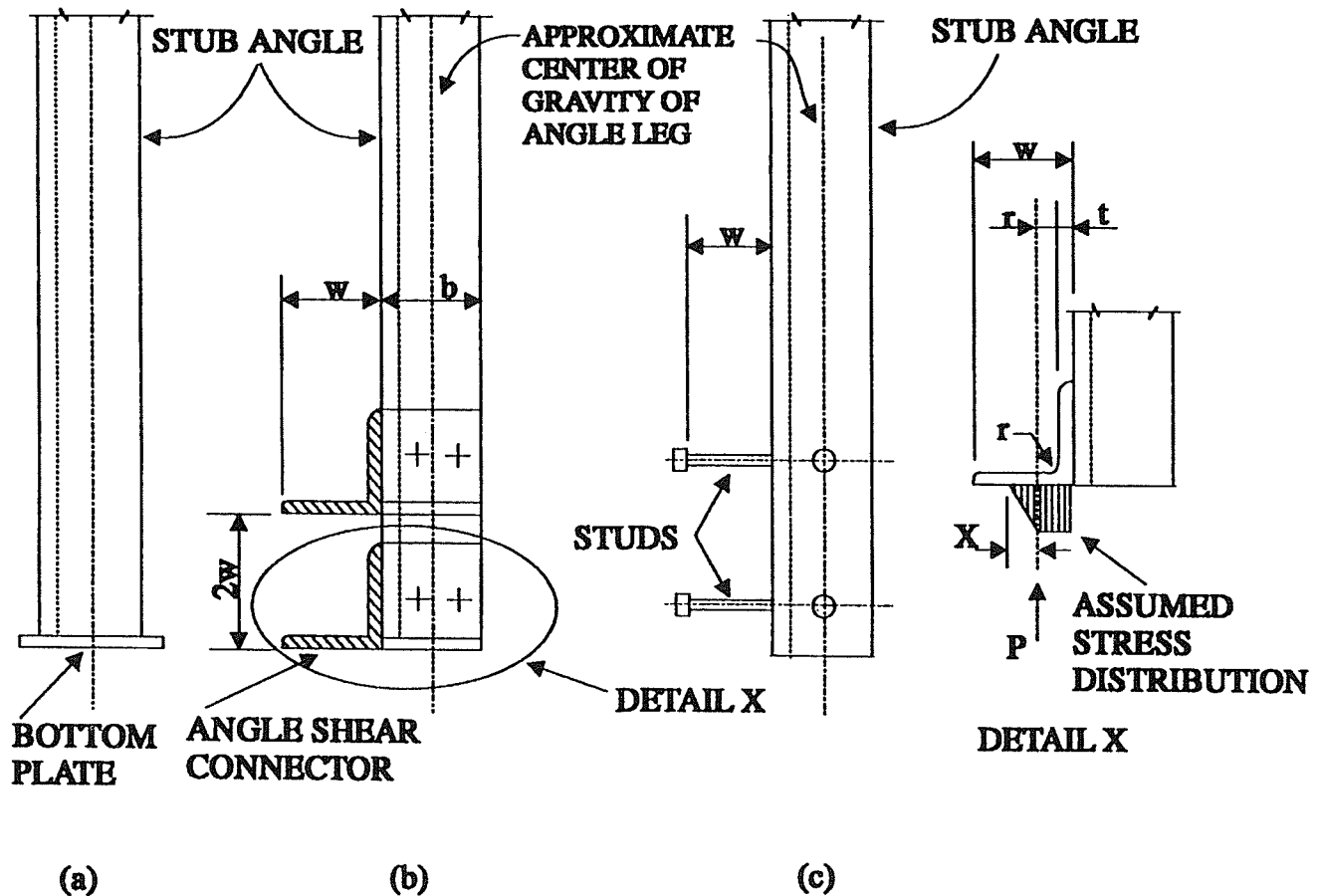

FIGURE 7.2. Stub Angles

If the anchor bolt lacks sufficient embedment length, the tensile load shall be transferred to the concrete by the end connection. The compressive load shall be transferred to the concrete or grout by the base assembly. The shear load is assumed to be transferred to the concrete by shear friction based upon the clamping force on the base assembly.

7.2.4.3 Smooth or Deformed Bars with Base Assembly Not in Contact with Concrete or Grout

If the base assembly is permanently supported on anchor bolt leveling nuts, the transfer of the tensile or compressive load to the concrete shall conform to the following:

- (a) For smooth bars by the end connection; and
- (b) For deformed bars by bond between the concrete and the bar; if sufficient embedment length is not provided, the end connection shall take the entire load.

The shear load shall be transferred to the concrete by side-bearing pressure. The anchor bolt shall be checked for a combination of tension, bending, and shear, as well as compression, bending, and shear. If the clearance between the base assembly and the concrete does not exceed twice the bolt diameter, a bending stress analysis of the anchor bolt is not normally required.

7.3 DETERIORATION CONSIDERATIONS

Steel that is galvanized, or otherwise protected, shall have a minimum thickness of 3/16 in. (4.8 mm) when exposed to corrosion at the ground level or below.

7.4 DESIGN OF STUB ANGLES AND ANCHOR BOLTS

7.4.1 Stub Angles in Concrete

The stub angle, at the plane of intersection with the concrete, shall be checked for a combination of tension plus shear and compression plus shear, as follows.

$$A_a = \frac{P}{F_y} + \frac{V}{0.75F_y} \tag{7.4-1}$$

where

- A_a = gross area of stub angle, or net area, if there is a hole at the intersecting plane;
- P = tensile or compressive load on the stub angle;
- V = shear load parallel to the intersection plane; and
- F_y = specified minimum yield strength of stub angle.

7.4.2 Anchor Bolts with Base Assembly in Contact with Concrete or Grout

When the anchor bolt bases are subjected to up-lift and shear loads, the shear load shall be assumed to be transferred to the concrete by shear friction based upon the clamping force of the anchor bolts. The area of steel required shall be:

$$A_s = \frac{T}{F_y} + \frac{V}{(\mu)0.85F_y} \tag{7.4-2}$$

The stress area through the threads is given by:

$$A_s = \frac{\pi}{4} \left(d - \frac{0.974}{n} \right)^2 \tag{7.4-3}$$

where

- T = tensile load on anchor bolt;
- V = shear load perpendicular to anchor bolts;
- F_y = specified minimum yield strength of anchor bolt;
- d = nominal diameter;
- n = number of threads per unit of length; and
- μ = coefficient of friction.

The values for μ (Figure 7.3) are:

- (a) 0.9 for concrete or grout against as-rolled steel with the contact plane a full plate thickness below the concrete surface;
- (b) 0.7 for concrete or grout placed against as-rolled steel with contact plane coincidental with the contact surface; and
- (c) 0.55 for grouted conditions with the contact plane between grout and as-rolled steel above the concrete surface.

When anchor bolt bases are subjected to a shear load or a combination of downthrust and shear loads, the anchor bolt area shall be checked by:

$$A_s = \frac{V - 0.3D}{(\mu)0.85F_y} \tag{7.4-4}$$

where

- D = downthrust load and the other terms as defined after Eq. 7.4-3.

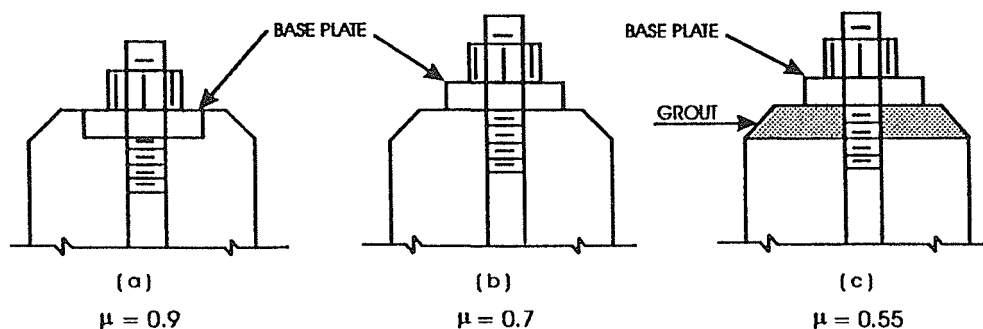

FIGURE 7.3. Coefficient of Friction (μ) Values for Various Conditions

When shear lugs are attached to the base assembly to transfer the shear to the concrete, the area of the anchor bolt need not be checked by Eqs. 7.4-2 and 7.4-4.

A combination of shear lugs and shear friction is not allowed.

7.5 DESIGN REQUIREMENTS FOR CONCRETE AND REINFORCING STEEL

The ultimate design stresses and strength factors of ACI 318 shall be used for the design of concrete and reinforcing steel in conjunction with the structure design-factored loads specified in Section 2.

7.5.1 Stub Angles

When a bottom plate is used (Figure 7.2(a)), the plate shall transfer the entire load in the stub angle to the concrete; concrete anchorage value shall be determined by the requirements of Section 7.5.2.

When shear connectors (Figures 7.2(b) or 7.2(c)) are used and spaced along the length of the stub angle, the requirements of Section 7.6 shall apply.

7.5.2 Smooth Bar Anchor Bolts

The anchorage value shall be limited by the pull-out strength of the concrete based on a uniform tensile stress, in ksi, of $0.126\phi\sqrt{f'_c}$ (in MPa, of $0.33\phi\sqrt{f'_c}$), acting on an effective stress area that is defined by the projecting area of stress cones radiating towards the surface from the bearing edge of the anchors.

The effective area shall be limited by overlapping stress cones, by the intersection of the cones with concrete surfaces, by the bearing area of anchor heads, and by the overall thickness of the concrete.

The angle for calculating the projected area shall be 45° . The factor shall be 0.65 for an embedded anchor head. When there is more than one anchor bolt in a line, overlapping stress cones shall be taken into account in determining the effective area.

The anchor head can be a nut, bolt head, or plate. The bearing requirements of ACI 318 need not be met if the anchor head satisfies the following conditions.

- The bearing area of the anchor head (excluding the area of the anchor bolt) is at least 1.5 times the area of the anchor bolt;
- The thickness of the anchor head is at least equal to the greatest dimension from the outermost bearing edge of the anchor head to the face of the anchor bolt; and
- The bearing area of the anchor head is approximately evenly distributed around the perimeter of the anchor bolt.

7.5.2.1 Minimum Embedment for Anchor Bolts

The minimum embedment depth shall be $12d\sqrt{F_u/58\Psi}$, where

d = nominal diameter;
 F_u = specified minimum tensile strength; and
 $\Psi = 1$ for F_u in ksi and 6.89 for F_u in MPa.

7.5.3 Deformed Bar Anchor Bolts

The embedment for deformed bars that are threaded and used as anchor bolts shall be in accordance with ACI 318; see Sections 7.2.4.2 and 7.2.4.3. Bars Grade 60 and above shall have a minimum Charpy-V notch requirement of 15 ft-lbs (20 m-N) at -20°F (-29°C), when tested in the longitudinal direction.

7.6 SHEAR CONNECTORS

7.6.1 Stud Shear Connectors (See Figure 7.2c)

The capacity Q_n of a stud shear connector shall be as given by Eq. 7.6-1, but not to exceed the value determined by Section 4.3.2.

$$Q_n = 0.5\phi A_{sc} \sqrt{f'_c E_c} \quad (7.6-1)$$

where

$\phi = 0.85$;
 A_{sc} = cross-sectional area of a stud shear connector;
 f'_c = specified compressive strength of concrete; and
 E_c = modulus of elasticity of concrete.

Values of Q_n from Eq. 7.6-1 are applicable only to concrete made with ASTM C33 aggregates. All AISC requirements (*AISC Manual of Steel Construction, Load and Resistance Factor Design, 1994*) for stud material and configuration, spacing, ratio of stud diameter to minimum thickness of material to which it is welded, and concrete properties and coverage shall be met.

7.6.2 Angle Shear Connectors (See Figure 7.2b)

The capacity P of angle shear connectors shall be determined by the following.

$$P = 1.19f'_c b(t + r + x/2)$$

$$x = t \left[\frac{F_y}{1.19f'_c} \right]^{1/2} \leq w - r - t, \quad (7.6-2)$$

where

f'_c = specified compressive strength of concrete;
 b = length of angle shear connector;
 t = thickness of angle shear connector;
 r = radius of fillet;
 F_y = specified minimum yield strength of steel; and
 w = width of angle shear connector leg.

The angle shear connector shall be located with its length symmetrical about the center of gravity of the stub angle leg. The connector shall be fastened to

the stub with sufficient bolts or welds to take both shear and moment. The minimum center-to-center spacing of shear connectors shall be $2w$.

7.7 TEST VERIFICATION

Design values other than those prescribed in this section may be used if substantiated by experimental or analytical investigations.

8.0 QUALITY ASSURANCE/QUALITY CONTROL

8.1 INTRODUCTION

The contract between the purchaser and the supplier shall state the responsibilities of each party and the conditions under which the work will be accepted or rejected.

8.2 QUALITY ASSURANCE

Quality Assurance (QA) is the responsibility of the purchaser. The purchaser's bid documents shall outline the QA methods, types of inspections and records that will be required to determine the acceptability of the product at each stage of the design, manufacturing, and construction process.

8.3 QUALITY CONTROL

Quality Control (QC) is the responsibility of the supplier. The supplier shall have a QC program consisting of a written document or a series of departmental memoranda that establishes the procedures and methods of operation that affect the quality of the work.

COMMENTARY

This Commentary is not a part of the ASCE Standard. It is included for informational purposes only. This information is provided as explanatory and supplementary material designed to assist in applying the recommended requirements.

The sections of this Commentary are numbered to correspond to the sections of the Standard to which they refer. Since it is not necessary to have supplementary material for every section in the Standard, there are gaps in the numbering sequence of the Commentary.

C2.0 LOADING, GEOMETRY, AND ANALYSIS

C2.1 INTRODUCTION

Design-factored loads are loads multiplied by load factors. The overload factors specified by the National Electric Safety Code (IEEE 1997) are load factors according to the terminology of this Standard.

C2.2 LOADS

Extensive background information on the selection of design-factored loads can be found in *Guidelines for Transmission Line Structural Loading* (ASCE 1991) and the *National Electrical Safety Code* (IEEE 1997).

Minimum legislated loads are specified in applicable codes covered by state and local authorities. Local climatic conditions may dictate loads in excess of legislated loads. These may include conditions of wind, or ice, or any of their combination at a specified temperature. Line security, which covers measures to prevent progressive line failure (cascading), should be addressed. This is often handled by specifying one or more longitudinal load conditions. Loads from anticipated construction and maintenance operations should be specified to ensure the safety of the personnel involved in those operations.

It is suggested that tower members that may be used for support by maintenance personnel when climbing a tower be capable of supporting a vertical load of 250 pounds (1100 N) applied independently of all other loads without permanent distortion of the

member. If end connection assembly bolts are properly tightened, the frictional restraining effect may be considered.

C2.3 GEOMETRIC CONFIGURATIONS

Three basic structure definitions are recommended: suspension, strain, and dead-end structures. The conductor phases pass through and are suspended from the insulator support points of a suspension structure. The strain structure conductor attachment points are made by attaching the conductor to a dead-end clamp, a compression or bolted fitting, and connecting the clamp, through the insulator string, directly to the structure. A jumper is looped through or around the structure body to electrically connect the adjacent spans. Dead-end structure conductor attachments are made the same way as for the strain structure.

Dead-end structures often have different tensions or conductor sizes on opposite sides of the structure; this creates an intact unbalanced longitudinal load. Overhead groundwires are attached to the structure using similar methods as outlined for the conductors. Additional nomenclature for the basic structure types is used to help identify the line angle at a particular structure.

The term “tangent” is prefixed to a basic structure type for zero line angle and the term “angle” is used when there is a line angle. Therefore, the following terminology is recommended: tangent suspension, angle suspension, tangent strain, angle strain, tangent dead-end, and angle dead-end.

Guyed structures rely on internal or external guy cables for their stability. They are normally less rigid than self-supporting structures and their deflections may affect electrical clearances.

In most structures, horizontal bracing is required to distribute shear and torsional forces. It is normally used at levels where there is a change in the slope of the structure leg. Horizontal bracing is also used in square and rectangular configuration structures to support horizontal struts and to provide a stiffer system to assist in reducing distortion caused by torsional and/or oblique wind loads. For structures that are taller than 200 ft (61 m), or heavy dead-end towers, it is suggested that horizontal bracing be installed at intervals not exceeding 75 ft (23 m). The spacing

of horizontal bracing is dictated by general stiffness requirements to maintain tower geometry and face alignment. Factors that affect this determination are: type of bracing system, face slope, dead load sag of the face members, and erection considerations that affect splice locations and member lengths.

C2.4 METHODS OF ANALYSIS

A lattice structure is described by a one-line design drawing that shows overall dimensions, member sizes, and locations. Because of the high degree of symmetry of most latticed structures, a transverse view, a longitudinal view, and a few horizontal cross-section or plan views are sufficient to describe the entire structure (Figure C2.1). For purposes of analysis, a latticed structure is represented by a model composed of members (and sometimes cables) interconnected at joints. Members are normally classified as primary and redundant members. Primary members form the triangulated system (three-dimensional truss) that carries the loads from their application points to the foundation. Redundant members are used to provide intermediate bracing points to the primary members to reduce the unbraced lengths of these primary members. They can easily be identified on a drawing (see dotted lines in Figure C2.1) as members inside triangles formed by primary members.

The locations of the joints in any model should be at the intersections of the centroidal axes of the members. Slight deviations from these locations will not significantly affect the distribution of forces.

Latticed structures are analyzed almost exclusively as ideal elastic three-dimensional trusses made up of straight members or cables and pin-connected at joints. Such elastic analyses produce only joint displacements, tension, and compression in members and tension in cables; moments from normal framing eccentricities are not calculated in the analysis. Moments in members because of framing eccentricities, eccentric loads, distributed wind load on members, and the like, can affect the member selection. These moments are considered in the member selection by the procedures described in Section 3.

First-order linear elastic truss analysis treats all members as linearly elastic (capable of carrying compression as well as tension), and assumes that the loaded configuration of the structure (used to verify final equilibrium) is identical to its unloaded configuration. Therefore, in a first-order linear analysis, the

secondary effects of the deflected structure are ignored and the forces in the redundant members are equal to zero. The redundant members need not be included in this type of analysis, since they have no effect on the forces in the load-carrying members. This type of analysis is generally used for conventional, relatively rigid, self-supporting structures.

In a second-order (geometrically nonlinear) elastic analysis, structure displacements under loads create member forces in addition to those obtained in a first-order analysis. These additional member forces are called the $P \Delta$ effects in building frameworks or transmission pole structures. They are automatically included in a second-order (or geometrically nonlinear) analysis that produces member forces that are in equilibrium in the deformed structure configuration (Peyrot 1985; ETADS 1989). A second-order elastic analysis may show that redundant members carry some load. Flexible self-supporting structures and guyed structures normally require a second-order analysis.

For purposes of analysis, it is sometimes assumed that bracing members with an L/r value greater than 300 cannot resist compressive loads. Such members are called tension-only members (see Section 5.1.8). Figure C2.2 shows the difference in load distribution between a tension-compression system and a tension-only system.

Other methods of analysis, which account for the load distribution in bracing members, may be used. There is some question as to the load that can be carried by a bracing member strained in compression beyond the value e_{\max} that corresponds to its theoretical capacity F_{\max} , Figure C2.3(a). Three different analysis methods have been used to model post-buckling member behavior. Method 1 assumes that the member is still capable of carrying its buckling load, irrespective of the amount of strain beyond e_{\max} , Figure C2.3(b). Method 2 assumes that the member carries no load after passing e_{\max} , Figure C2.3(c). Method 3 assumes that the compression member can carry a reduced load beyond e_{\max} (Prickett et al. 1989); the member load is modeled using a post-buckling performance curve, Figure C2.3(a).

When performing a computer analysis of an existing structure, careful attention must be given to the method of analysis employed when the structure was originally designed (Kravitz 1982). If the structure was originally designed by manual (algebraic or graphical) methods and the design loads are not changed, a three-dimensional computer analysis may indicate forces in the members that are different from

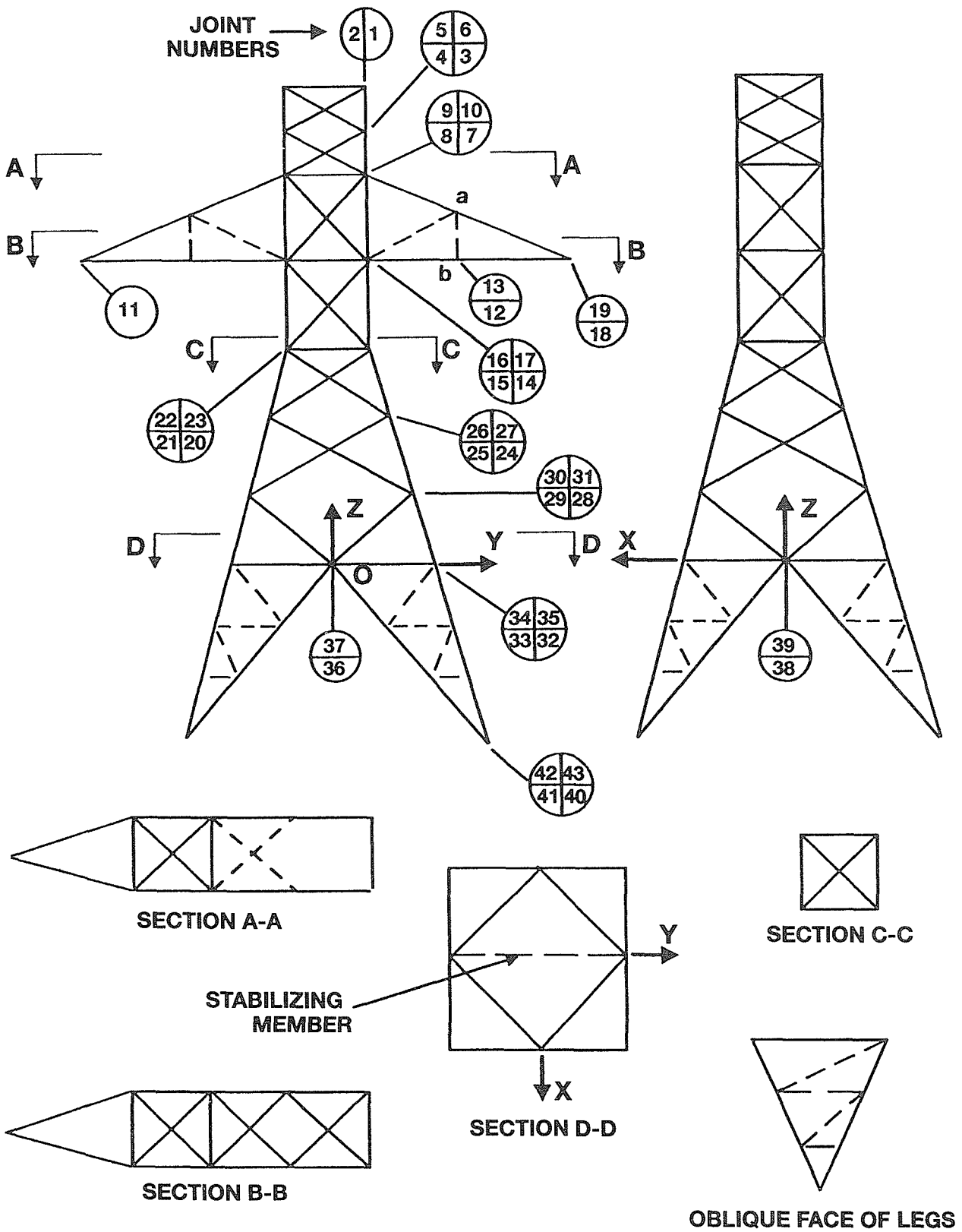

FIGURE C2.1. Model of Simplified Tower

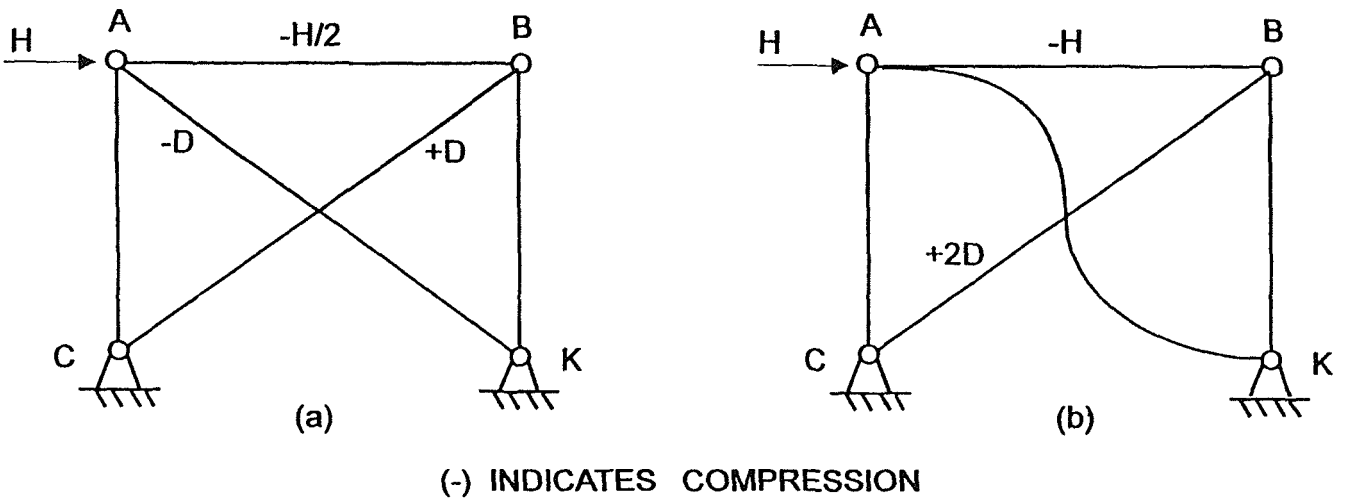

FIGURE C2.2. (a) Tension-Compression System; (b) Tension-Only System

those of the manual methods. The engineer should determine and document why the differences exist before proceeding with the new analysis. If the tower is to be upgraded and new design-factored loads specified, then it is normally more cost-effective to rely on a computer analysis. A correlation of past model assumptions with present model assumptions

should be performed for the entire structure. Detail drawings should be reviewed to ensure that members and connections are in agreement with the original design drawings.

If the included angle between a bracing member and the member it supports is small, the bracing member should not be considered as providing full

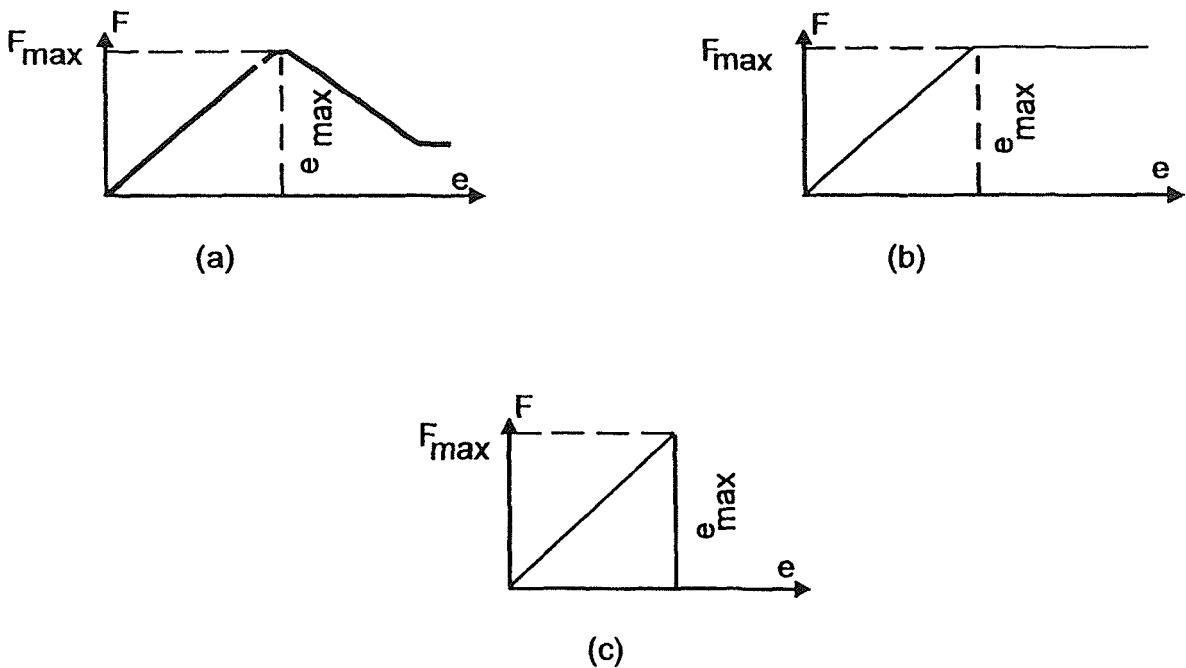

FIGURE C2.3. Relationships Between Member Compression Force and Shortening: (a) Actual Member; (b) Liberal Assumption; (c) Conservative Assumption

support; as the included angle approaches 15° , the supported member should be investigated for stability.

Moments can occur in a leg or cross-arm chord if the bracing is insufficiently stiff (Roy et al. 1984). Figure C2.4(a) represents qualitatively a situation where the bracing is sufficiently stiff to carry all the shear load H . Figure C2.4(b) represents a case where the bracing system, because of the small value of the angle and small diagonal member sizes, is insufficiently stiff; therefore, the diagonals carry only a portion of the shear; the remainder of the shear produces moments in the vertical members AC and BD . If moments are anticipated in leg members, it is prudent to use an analysis method that models such members as beams. Other members in the structure can still be modeled by truss elements.

Dynamic analysis of latticed structures can be performed with a general-purpose finite element computer program. However, there is no indication that such an analysis is needed for design purposes, even in earthquake-prone areas (Long 1974).

Specialized computer programs for the analysis of latticed transmission structures (Rossow et al.

1975; ETADS 1989; EPA 1987; ATADS 1995; Power Line Systems 1995; etc.) should include the following features: automatic generation of nodes and members that utilize linear interpolations and symmetries, interactive graphics to ascertain model correctness, provisions for tension-only members and for automatic handling of planar nodes, and mechanisms (unstable subassemblies) that may develop in a small group of nodes and members. Out-of-plane instabilities or mechanisms are generally prevented in actual structures by the bending stiffness of continuous members that pass through the joints.

Joints 3 through 6 of Figure C2.1 are planar nodes; that is, all members meeting at those points lie in the same plane. Joints 12 and 13 are also planar joints if the redundant member "ab" is not included in the model. The horizontal bracing in section $D-D$ is a mechanism in the absence of the member shown as a dotted line.

Guyed structures and latticed H-frames may include masts built-up with angles at the corners and lacing in the faces as shown in Figure C2.5. The overall cross-section of the mast is either square, rectangular, or triangular. Latticed masts typically in-

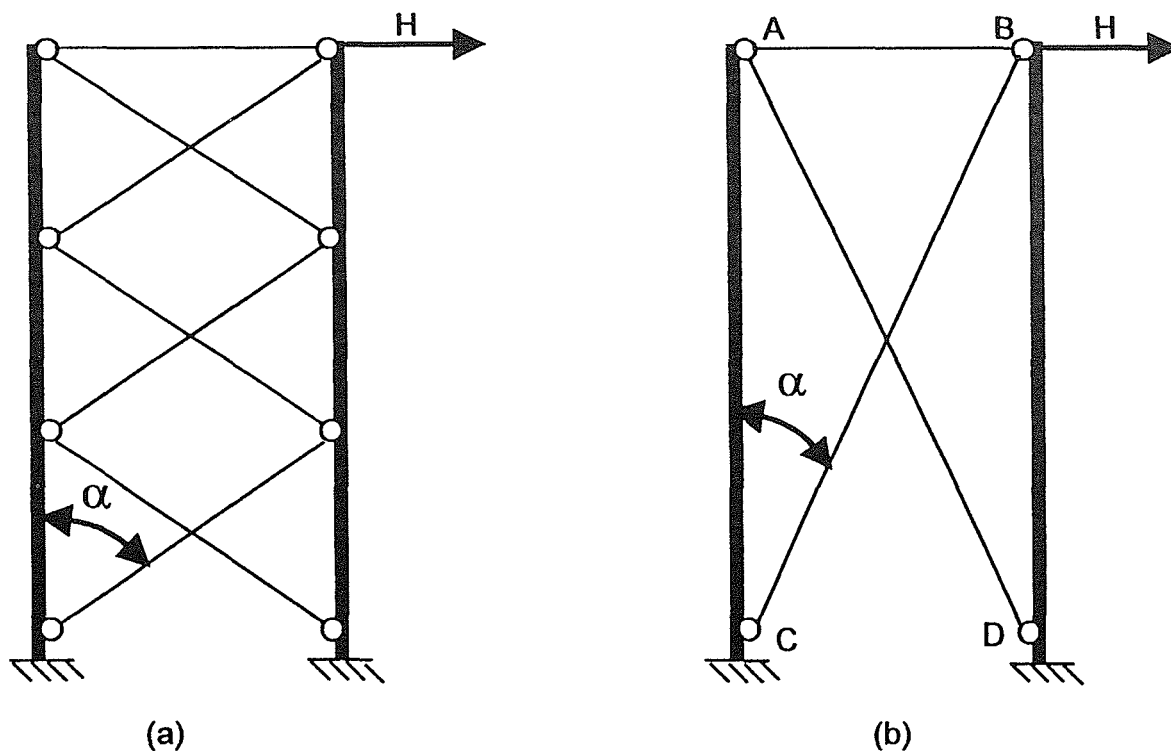

FIGURE C2.4. Braced Systems Under Shear Load: (a) Stiff Bracing; (b) Insufficiently Stiff Bracing

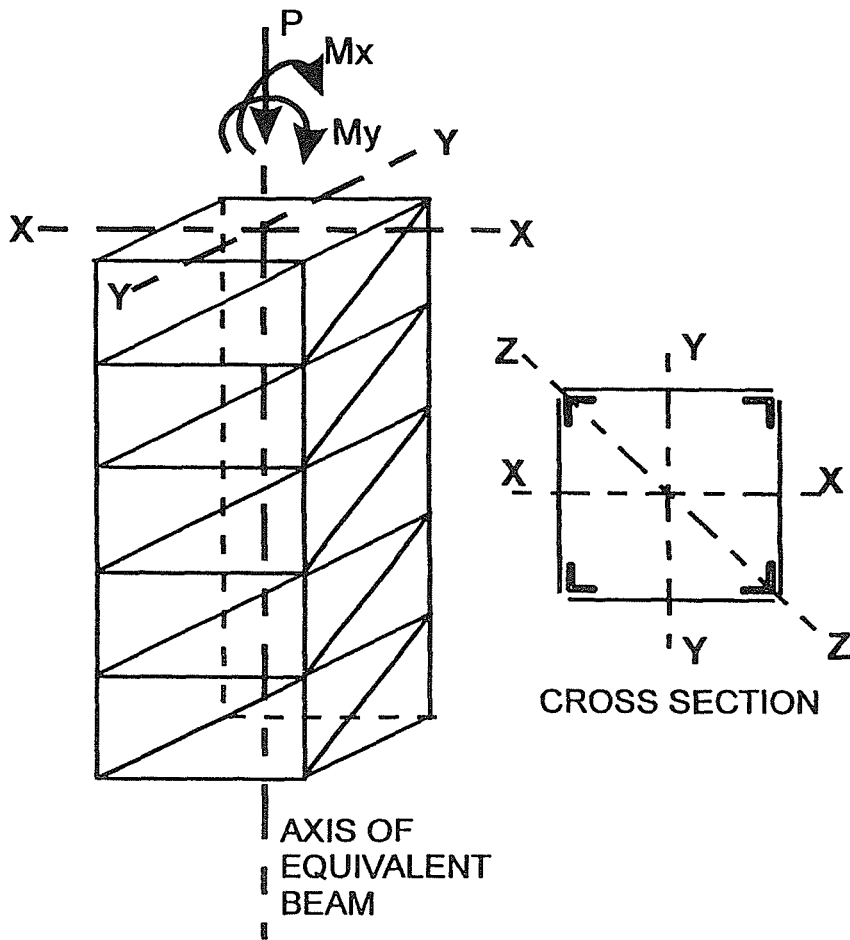

FIGURE C2.5. Segment of Latticed Mast Idealized as Beam

clude a very large number of members and are relatively slender, that is, may be susceptible to second-order stresses. One alternative to modeling a mast as a three-dimensional truss system is to represent it by a model made up of one or several equivalent beams. The properties of an equivalent beam that deflects under shear and moment can be worked out from structural analysis principles. The beams are connected to form a three-dimensional model of the mast or an entire structure. That model may be analyzed with any three-dimensional finite element computer program. If large deflections are expected, a second order (geometrically nonlinear) analysis should be used. Once the axial loads, shears, and moments are determined in each equivalent beam, they can be converted into axial loads in the members that make up the masts.

C3.0 DESIGN OF MEMBERS

C3.1 INTRODUCTION

This standard is suitable for steels with yield points up to 65 ksi (448 MPa) and for width-to-thickness values of 25 for projecting elements, such as angle legs and channel flanges. The recommendations are intended for both hot-rolled and cold-formed members. Recommendations have also been included covering guyed transmission structures.

Test experience may indicate that these recommendations are conservative for specific shapes or connections. Higher values may be used where they are verified by tests, provided the results are adjusted to the ASTM yield and tensile values of the material

and for differences between the nominal design dimensions of the member and the actual cross-sectional dimensions of the test specimens. The properties of the material should be determined by tests on standard coupons taken in accordance with the requirements of the AISI Specification (AISI 1986).

C3.2 MATERIAL

A ratio of $F_u/F_y \geq 1.15$ is suggested for steel used for members.

C3.3 MINIMUM SIZES

If weathering steel is to be used, consideration should be given to increasing the suggested minimum thickness.

C3.4 SLENDERNESS RATIOS

Tension-only members used as cross-brace members and tension-hanger members are not designed to resist compression forces. This is accomplished by maintaining high L/r values for these members. When tension-only members are subjected to compressive forces they bow out-of-plane without permanent set and the compressive forces are redistributed to other members of the structural system. Upon removal of the applied compressive load the tension-only member returns to its original position. Experience has shown that maintaining or limiting L/r of 300 or greater accomplishes the desired performance.

In special cases based on structure geometry and loads some tension-hanger members may not be subjected to compressive forces. For this case lower L/r members could be used with caution and are allowed under the provisions of Section 3.16 (Test Verification), however, L/r values less than 300 for tension-only members are not appropriate in a general provision.

Damaging vibration of steel members in latticed towers usually occurs at wind speeds less than 20 mph (32 km/h) since a nearly constant velocity is required to sustain damaging vibration. Tests on a number of shapes with L/r values of 250 show that the possibility of damaging vibration is minimal (Carpena and Diana 1971; Cassarico et al. 1983). Tension-hanger members are prone to vibration, but

L/r values as large as 375 have been used successfully.

In areas of steady winds over extended periods, such as mountain passes or flat plains, allowable L/r values may need to be reduced. Where severe vibration is a concern, careful attention must be given to framing details. The practice of blocking the outstanding leg of angles to facilitate the connection should be avoided.

C3.5 PROPERTIES OF SECTIONS

Evaluation of torsional-flexural buckling involves some properties of the cross-section that are not encountered in flexural buckling. Procedures for computing the torsional constant J , the warping constant C_w , the shear center, and other properties are given in the *Cold-Formed Steel Design Manual* (AISI 1987), Timoshenko and Gere (1961), Yu (1986), and other sources. The AISC Manuals of Steel Construction (1989, 1994) give tabular values for various standard shapes.

For cold-formed shapes with small inside-bend radii (twice the thickness), section properties can be determined on the basis of square corners. Equations based on round corners are given in the *Cold-Formed Steel Design Manual* (AISI 1987). Normally, the differences in properties based on square and round corners are not significant.

C3.6 DESIGN COMPRESSION

The Structural Stability Research Council (SSRC) formula, originally developed in 1966, for the ultimate strength of the centrally loaded column in the inelastic range and the Euler formula in the elastic range are used in this Standard. Test experience on tower members is limited in the range of L/r from 0 to 50, but indications are that the SSRC formula applies equally well in this range if concentric framing details are used.

C3.7 COMPRESSION MEMBERS: ANGLES

A single angle in axial compression can fail by torsional-flexural buckling, which is a combination of torsional buckling and flexural buckling about the u -axis, by z -axis flexural buckling, or by local buckling of the legs. Local buckling and purely torsional buck-

ling are identical if the angle has equal legs and is simply supported and free to warp at each end; furthermore, the critical stress for torsional-flexural buckling is only slightly smaller than the critical stress for purely torsional buckling, and for this reason such members have been customarily checked only for flexural and local buckling.

C3.7.3 Determination of F_a

The ratio w/t of flat width to thicknesses that enables the leg to reach yield stress without buckling locally has been set at $80/\sqrt{F_y}$ for F_y in ksi ($210/\sqrt{F_y}$ for F_y in MPa). The reduced strength of legs with larger values of w/t is given by Eqs. 3.7-2 and 3.7-3. The effect of the reduced local-buckling strength on the flexural-buckling strength is accounted for by substituting the reduced value F_{cr} for F_y in Eqs. 3.6-1 and 3.6-3. Unequal-leg angles can be designed following this procedure by establishing the design stress based on the w/t value of the long leg. Member strengths computed by this procedure are in very good agreement with test results on both hot-rolled and cold-formed single angle members (Gaylord and Wilhoite 1985).

C3.7.4 Effective Lengths

The K factors for angle members depend upon the connection design for the member. The effective length of leg sections having bolted connections in both legs is assumed to be the actual length ($K = 1$). In the design of members, the length L is usually determined from working point to working point on the design drawings. For other angles in compression, eccentricity of the connection is the predominant factor in the lower L/r range and is accounted for by specifying effective slenderness values KL/r . In the higher L/r range, rotational restraint of the members becomes the predominant factor and is also accounted for by specifying effective slenderness values KL/r . The breakpoint is taken as $L/r = 120$. Member strengths computed by this procedure are in very close agreement with numerous tests on both hot-rolled and cold-formed angles (Gaylord and Wilhoite 1985). Eccentricities at leg splices should be minimized, and the thicker sections should be properly butt-spliced.

Angle members connected by one leg should have the centroid of the bolt pattern located as close to the centroid of the angle as practical. Except for some of the smaller angles, normal framing eccentricity implies that the centroid of the bolt pattern is located between the heel of the angle and the centerline

of the connected leg. When this is not the case, due consideration should be given to the additional stresses induced in the member.

To justify using the values of KL/r specified in Eqs. 3.7-9, 3.7-10, 3.7-13, and 3.7-14 the following evaluation is suggested.

- (a) The restrained member must be connected to the restraining member with at least two bolts; and
- (b) The restraining member must have a stiffness factor I/L in the stress plane ($I =$ moment of inertia and $L =$ length) that equals or exceeds the sum of the stiffness factors in the stress plane of the restrained members that are connected to it. An example is shown in Figure C3.1; and
- (c) Angle members connected solely to a gusset plate should not be considered to have end restraint against rotation. An angle member with an end connection to both a gusset plate and the restraining angle member should have adequate bolts in the restraining angle member to provide end restraint against rotation.

The critical loading condition for compression members being analyzed and the members providing joint restraint should be compared. If all members at a joint can buckle at the same time, then the joint cannot provide restraint for any of the members framing into it.

Redundant members provide intermediate support for stressed members. The L/r limitations specified in Section 3.7.4.3 normally ensure that the redundant support is adequate to provide support for the stressed member. Studies indicate that the magnitude of the redundant support required is dependent on the initial crookedness and the L/r value of the supported member. Common design practice is to design redundant members for 1 to 2.5% of the load in the supported member.

C3.7.4.4 Unsupported Length With Varying Forces

The effective length factor (K) for an unsupported length of a member with varying force magnitudes such as for the bracing systems shown in Figure C3.2 can be determined using Eqs. 3.7-15a and b (Johnston 1988). The change in force at the subpanel point will have the effect of providing partial restraint for both rotation and translation at this point. When out-of-plane support is provided and the load in the member is changing each subpanel of the member shall be designed as an individual member with due consideration of any eccentricities when selecting the value of KL/r .

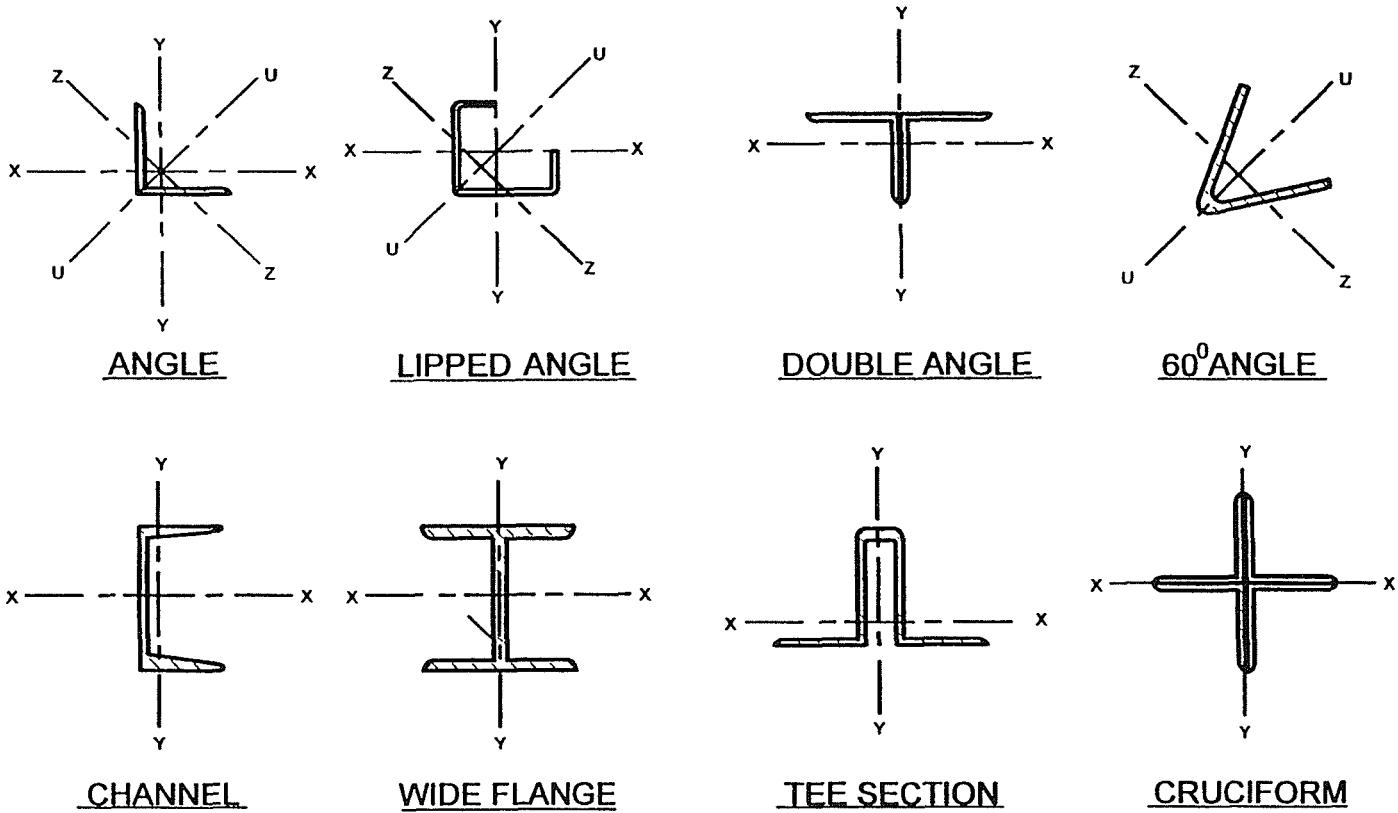

FIGURE C3.1. Typical Cross-Sections

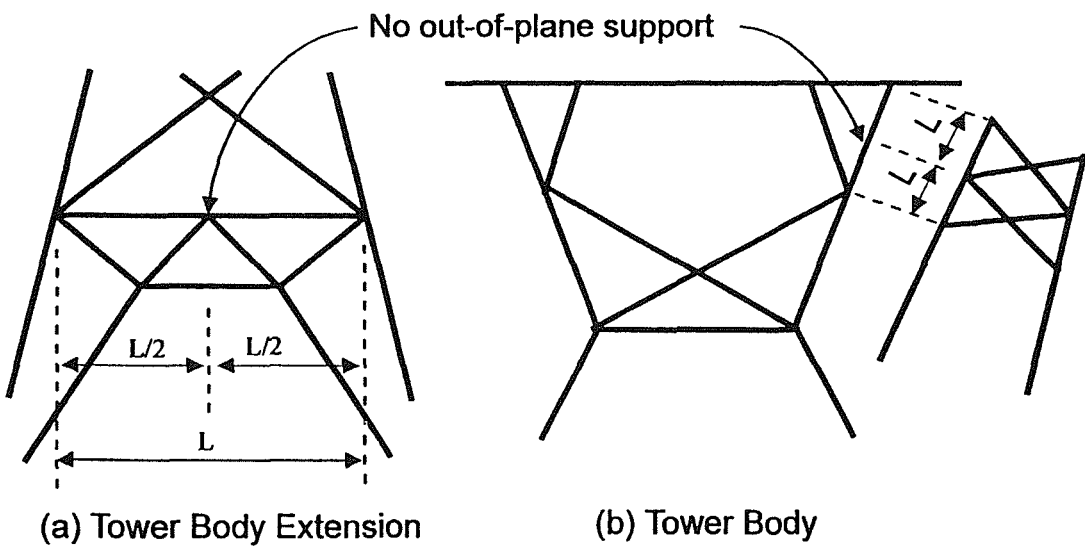

FIGURE C3.2. Typical Subpanel Configurations

C3.8 COMPRESSION MEMBERS: SYMMETRICAL LIPPED ANGLES

Lips increase the local buckling strength of the legs of an angle and in some applications lipped angles show an advantage over plain angles. Since the local buckling strength of the angle is not equivalent to torsional buckling of the angle, torsional-flexural buckling must be considered. The design compressive stress for torsional-flexural buckling is determined by using an equivalent radius of gyration r_{if} (Eq. 3.8-1) in the design column stress formulas (Eqs. 3.6-1 and 3.6-2).

The effective-length coefficient in Eqs. 3.6-1, 3.6-2, and 3.8-2 is $K = 1$ if the member is free to warp and to rotate about the u axis at each end.

If warping and u -axis rotation are prevented at both ends, $K = 0.5$; if they are prevented at only one end, $K = 0.7$. Mixed end conditions can be treated by replacing r_t and r_u in Eq. 3.8-1 with r_t/K_t and r_u/K_u , where K_t and K_u are the effective-length coefficients for torsional and u -axis buckling, respectively. Eq. 3.8-1 in this form gives the value of K/r_{if} by which L is multiplied for use in Eqs. 3.6-1 and 3.6-2. However, $K_t = 1$ should be used in Eq. 3.8-2 when it is used to compute the adjusted values KL/r specified in Section 3.7.4. Gaylord and Wilhoite (1985) and Zavelani (1984) provide additional test verifications.

If there are no intermediate supports, the design stress is given by Eqs. 3.6-1 and 3.6-2, using for KL/r the larger of KL/r_z and KL/r_{if} . If there are intermediate supports, the length L used to determine the slenderness ratio depends on the nature of the support, that is, whether it restrains only flexural buckling, only torsional-flexural buckling, or both.

C3.9 COMPRESSION MEMBERS NOT COVERED IN SECTIONS 3.7 AND 3.8

C3.9.2 Maximum w/t Ratios

Most of the shapes other than angles that are likely to be used in transmission towers will have element slenderness ratios w/t small enough to develop a uniform distribution of the stress F_a given by Eqs. 3.6-1 and 3.6-2 over the full cross-sectional area. Where this is not the case, the post-buckling strength of elements that buckle prematurely is taken into account by using an effective width of the element in determining the area of the member cross-section. The effective width of an element is the width that

gives the same resultant force at a uniformly distributed stress F_a as the nonuniform stress that develops in the entire element in the post-buckled state.

C3.9.3 Effective Widths of Elements in Compression

Effective widths in this section are derived from formulas in the *Specification for the Design of Cold-Formed Steel Structural Members* (AISI 1986). Only the effective widths of Section 3.9.3.1 are needed for the uniform stress distribution in axially loaded compression members.

Stress gradients (Section 3.9.3.2) occur in members in bending, and effective widths for this case are needed only for beams and eccentrically loaded compression members.

Note that the effective widths for axially loaded members are determined at the design stress F_a based on the radius of gyration of the gross cross-section, whereas the allowable force P is obtained by multiplying F_a by the gross area if all elements are fully effective and by the reduced area if the effective widths of the elements are smaller than the actual widths.

The types of buckling that must be checked for axially loaded members with symmetric cross-sections are covered in Sections 3.9.4–3.9.7. For members that may be subject to torsional or torsional-flexural buckling, an equivalent radius of gyration r_t for doubly symmetric and point symmetric sections and r_{if} for singly symmetric sections are specified to be used in determining the design stress F_a by Eqs. 3.6-1 and 3.6-2. Note that r_{if} and r_t (Eqs. 3.8-1 and 3.8-2) are referred to the principal axes u and z of angles (Figure C3.3). In adjusting the formulas for the x and y principal axes of other sections, u is the axis of symmetry. Therefore, when either the x -axis or the y -axis is the axis of symmetry, it must be substituted for u in Eq. 3.8-1, and also whenever it appears in the list of symbols following Eq. 3.8-2.

C3.9.8 Nonsymmetric Cross-Sections

An analysis based on the elastic buckling stress of a nonsymmetric member, which requires the solution of a cubic equation, is suggested in Zavelani and Faggiano (1985). In general, this will give an upper bound to the allowable value. A lower bound can be obtained by proportioning the member so that the maximum combined stress due to the axial load and moment equals the yield stress (Madugula and Ray 1984).

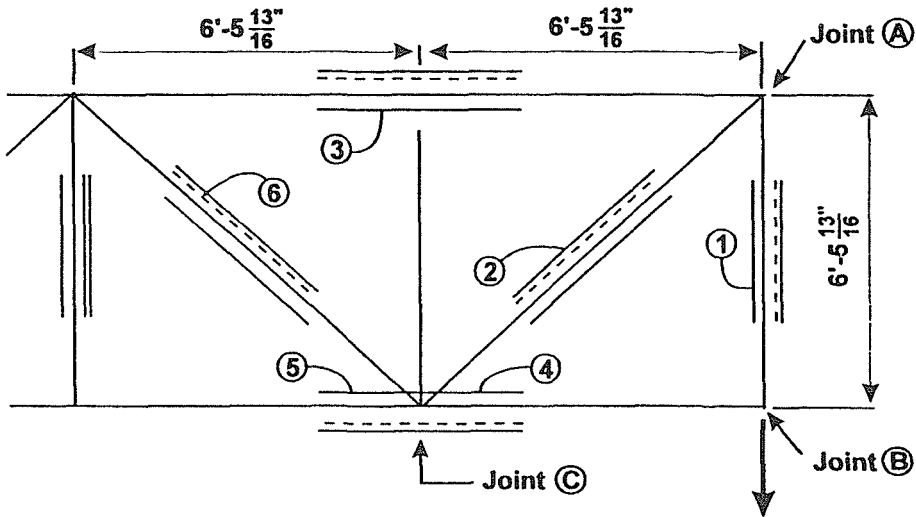

$$I = r^2 A \text{ and } I/L = (rA)/(L/r)$$

(1) L2 X 2 X 1/8: one bolt connection—joint restraint not a consideration—tension member.

(2) and (6) L2½ X 2½ X 3/16—two bolt connection— $L = 110$ in.;
 $r_{xx} = 0.778$; $A = 0.902$ sq. in.

$$\frac{rA}{L/r} = \frac{0.778 \times 0.902}{110/0.778} = 0.005 \text{ (in truss plane)}$$

(3) L2½ X 2½ X 3/16; $L = 155.6$ in.; $r_{xx} = 0.778$; $A = 0.902$ sq. in.

$$\frac{rA}{L/r} = \frac{0.778 \times 0.902}{155.6/0.778} = 0.004 \text{ (in truss plane)}$$

Joint restraint not a consideration—tension member.

(4) and (5) L4 X 4 X 1/4; $L = 77.8$ in.; $r_{xx} = 1.25$; $A = 1.94$ sq. in.

$$\frac{rA}{L/r} = \frac{1.25 \times 1.94}{77.8/1.25} = 0.039 \text{ (in truss plane)}$$

Joint (A): (3) < (2) $0.004 < 0.005$ No restraint for (2).

Joint (B): Single bolt connection—no restraint.

Joint (C): (4) + (5) > (2) + (6) $2 \times 0.039 > 2 \times 0.005$ —Partial restraint for (2) and (6) at this joint

Member (2)—Partial restraint at one end; $r_{zz} = 0.495$; (Eq. 3.7-9)

$$L/r_{zz} = 110/0.495 = 222.2; KL/r_{zz} = 28.6 + 0.762 \times 222.2 = 198;$$

Member meets requirements of compression member.

FIGURE C3.3. Member Restraint Determination (All dimensions in inches: 1 in. = 25.4 mm)

C3.10 TENSION MEMBERS

C3.10.5 Guys

The elastic limit of wire rope is approximately 65% of its strength; therefore, the specified 0.65 times the minimum breaking strength, is consistent with the standards ultimate stress F_y for tension members. The factor of safety of a guy with respect to its elastic limit is equal to the load factor, as with other structural components.

The determination of the tension of guys must be based on the movement of the guy anchor under load, the length and size of the guy, the allowable deflection of the structure, and the modulus of the guy. On tangent structures, pretensioning of guys to 10% of their rated breaking strength is normally sufficient to avoid a slack guy.

C3.12 AXIAL COMPRESSION AND BENDING

Equations 3.12-1 and 3.12-2 are the same as the corresponding formulas in the AISC Allowable Stress Design specification and the AISI specification, except that in the AISC specification they are given in terms of axial stress f_a and bending stress f_b instead of force P and moment M . Values of C_m are given here only for the case where there is no lateral displacement of one end relative to the other, since the lateral-displacement (sideways) case is not likely to be found in latticed transmission towers.

Both the AISC and AISI specifications give an alternative simplified formula which may be used if f_a/F_a is less than 0.15. Because this case is likely to be rare in transmission tower work, the corresponding formula is not given in this Standard.

C3.13 AXIAL TENSION AND BENDING

The terms $1/(1 - P/P_e)$ in Eq. 3.12-1 account for the increase in the moments M_x and M_y due to the eccentricity of the compression force P caused by the bending of the member. If the axial force is tension, however, its effect decreases the moments. Therefore, the inclusion of terms in Eq. 3.13-1 for decreasing the moments would be logical. This is not usually done, however, and the resulting simpler formula is used in this Standard.

Note that M_{ax} and M_{ay} are to be determined according to Section 3.14. Therefore, the effects of lat-

eral buckling for members not supported laterally are taken into account even though the lateral-buckling moment is based on a compressive stress. In other words, Eq. 3.13-1 is not based on the addition of axial tension and tensile stresses due to bending. This logic can be seen by considering the case in which P and M_x are both zero. This gives $M_y = M_{ay}$, and if the member is not supported against lateral buckling, M_{ay} should be the lateral-buckling moment.

Equation 3.13-1 is the same as the corresponding equation in the *AISC Load and Resistance Factor Design Specification for Steel Buildings* (AISC 1994).

C3.14 BEAMS

Formulas in this section for determining allowable moments differ in form from those in the AISC and AISI specifications in that the allowable compressive stress for laterally unsupported members is computed from the allowable-stress formulas for axial compression through the use of an equivalent radius of gyration.

C3.14.4 I, Channel and Cruciform Sections

Equation 3.14-1, which gives the equivalent radius of gyration for doubly symmetric I sections, symmetric channels, and singly or doubly symmetric cruciform sections, takes both the St. Venant torsional stiffness J and the warping stiffness C_w into account. Values of $K = \sqrt{K_y K_x}$ and C_b for a number of cases for which the member and conditions are the same for warping and y-axis rotation (e.g., warping and y-axis rotation both permitted or both prevented) are given by Clark and Hill (1960) and Gaylord et al. (1992). Two formulas are used in the *AISC Specification for Structural Steel Buildings* (AISC 1989). One is obtained by taking $C_w = 0$ and the other by taking $J = 0$ and expressing the results in terms of other more familiar properties of the cross-section. The larger of the two design stresses so obtained is used because both underestimate the buckling strength due to the omissions just mentioned. The two formulas can be used only for doubly symmetric I sections and singly symmetric I sections with the compression flange larger than the tension flange. Only one of the two applies to channels. On the other hand, formulas in the *AISI Specification for Design of Cold-Formed Steel for Structural Members* (AISI 1986), are derived by assuming $J = 0$ because it is usually relatively small for thin-walled shapes of cold-formed members. However, Eq. 3.14-1 is not difficult to use,

and it has the advantage of giving more accurate values of the buckling stress.

C3.14.6 Singly Symmetric I and T Sections

The approximate procedures for T sections and singly symmetric I sections give very good results.

C3.14.7 Other Singly Symmetric Open Sections

The formulas in this section are expressed in different terms from those in the AISI specification. However, they give identical results. Gaylord et al. (1992) give a typical example.

C3.14.8 Equal Leg Angles

The formulas in this section give critical moments for pure bending (constant moment) of equal leg angles and therefore are conservative for cases where there is a moment gradient, as for a uniformly loaded beam. However, they do not account for twisting of the angle, so they are not conservative if the load does not act through the shear center. Tables of allowable uniformly distributed load perpendicular to a leg, based on formulas that account for twist due to load eccentricity of $\pm b/2$, and which have been confirmed by an extensive series of tests, are available (Madugula and Kennedy 1985; Leigh et al. 1984). The tables cover angles with unequal legs, as well as those with equal legs. The loads are based on an allowable stress of $0.6F_y$ in Madugula and Kennedy (1985), and $0.66F_y$ in Leigh et al. (1984), so that the tabulated values must be divided by 0.6 and 0.66, respectively, to obtain values in conformity with tower design practice.

Predictions of the formulas in this section for load perpendicular to a leg are in good agreement with the values in Leigh et al. (1984) for beam spans up to $L/r_z = 250$. The tabular values range from about 92% for the relatively thin angles ($b/t = 16$) to about 115% (b/t about 8) of the formula values using the centerline section moduli of Eq. 3.14-11, and from about 94 to 130% using overall dimension section moduli. The overprediction of the thin angles is partially compensated for by the fact that the formulas give the critical uniform moment. Nevertheless, if the formulas are used for angles with b/t larger than 16, it is suggested that the resulting allowable moments be reduced by 10% if the member is not to be tested.

Deflections may be computed as the resultant of the u - and z -axis deflection components determined by resolving the moment M into the u - and z -axis.

There are no established limits of deflection for beams in transmission tower applications.

C3.15 DESIGN SHEAR

C3.15.1 Beam Webs

The upper limit of h/t in the AISC specification is given by a formula involving F_y . The limiting value 200 of this section, which is the same as the AISI specification limit, equals the AISI limit for $F_y = 60$ ksi (413 MPa) and is, therefore, adequate for steels with $F_y \leq 60$ ksi (413 MPa). It is unlikely that webs thinner than those allowed by the 200 limit will be needed in transmission towers.

The design shear stresses given here are the same as those in the AISC and AISI specifications multiplied by the AISC and AISI factors of safety.

C4.0 DESIGN OF CONNECTIONS

C4.1 INTRODUCTION

The purchaser's procurement specifications should specify if the end and edge distances are minimum values that cannot be underrun. Tolerances for sheared and cut ends are normally established by the supplier. Edge distances are controlled by the gage lines selected, and the detailer must provide for normal rolling tolerances to avoid possible underrun of the edge distances. The rolling tolerances contained in ASTM Specification A6 should be used as a guide (ASTM 1996).

Bolts, such as A394, are installed to the snug-tight condition or to some specified minimum torque. Even if the bolt is supplied with a lubricant, it is difficult to fully torque a hot-dipped galvanized bolt due to the buildup of the zinc coating on the threads as the nut is tightened. Consequently, locking devices are used by many utilities to minimize possible loosening of the nut due to vibration or flexure of the structure joints.

C4.3 FASTENERS

C4.3.2 Bolt Shear Capacity

Bolts, such as A394 bolts (ASTM 1993) are typically installed to the snug-tight condition or to some specified minimum torque. Thus, the load transfer

across a bolt is governed by direct shear rather than friction. ASTM A394 provides the specified minimum shear values when threads are included in or excluded from the shear plane. The design shear of $0.62F_u$ for bolts that do not have an ASTM specified shear stress is conservative (Kulak et al. 1988).

C4.3.3 Bolt Tension Capacity

The specified tensile stresses approximate those at which the rate of elongation of the bolt begins to increase significantly. The ASTM proof load stress is approximately equal to the yield stress, and $0.6F_u$ is a conservative estimate for bolts for which the proof load is not specified.

If design stresses exceed the yield stress, permanent stretch can occur in the bolt. This could loosen the nut and cause a loss of tightness in the joint.

C4.3.4 Bolts Subject to Combined Shear and Tension

Tests on rivets and bolts indicate that the interaction between shear and tension in the fastener may be represented by formulas that plot as ellipses (Kulak et al. 1988; Higgins and Munse 1952; Chesson et al. 1965). Therefore, an elliptical expression, with major and minor axes based upon the design shear and tension values given in Sections 4.3.2 and 4.3.3, has been specified.

C4.4 DESIGN BEARING STRESS

The design bearing stress is the same as the allowable value in the 1978 AISC specification. This may seem unduly conservative since in the AISC specification the allowable value is applied to the service (unfactored) load whereas in the Standard it is applied to the factored load. However, it conforms with experience in the tower industry. Designs produced with bearing values less than or equal to $1.5F_u$ and conforming to the other provisions of this document have demonstrated satisfactory control over bolt-hole ovalization during full-scale tower tests. Furthermore, the AISC value was reduced to $1.2F_u$ in the 1989 edition of the specification if deformation around the hole is a consideration.

When applying these provisions, the designer must recognize that the required end and edge distances depend upon the bearing stress in the connection. It may be useful to reduce the bearing stress below the maximum allowed design value, as this may

permit a reduction in the end and edge distances required.

The design-bearing value on the bolts must be checked if the tensile strength, F_u , of the member material exceeds the F_u value of the bolt. This would occur if an A394, Type 0 bolt ($F_u = 74 \text{ ksi} = 510 \text{ MPa}$) is used to connect an A572-Grade 65 material ($F_u = 80 \text{ ksi} = 551 \text{ MPa}$). The full diameter of the bolt should be used for this calculation, with design bearing stress equal to $1.5F_u$ of the bolt (Wilhoite 1985).

C4.5 MINIMUM DISTANCES

C4.5.1 End Distance

The provisions of this section are applicable to sheared and mechanically guided flame cut ends.

Equation 4.5-1 provides the end distance required for strength. The required end distance is a function of the load being transferred in the bolt, the tensile strength of the connected part, and the thickness of the connected part. Test data confirm that relating the ratio of end distance to bolt diameter to the ratio of bearing stress to tensile strength gives a lower bound to the published test data for single fastener connections with standard holes (Kulak et al. 1988). The end distance required by the preceding expression has been multiplied by 1.2 to account for uncertainties in the end distance strength of the members (Kulak et al. 1988). For adequately spaced multiple bolt connections, this expression is conservative.

Equation 4.5-2 is a lower bound on end distance that has been successfully used in tower practice in stressed members. A minimum end distance of $1.2d$ has been specified for redundants since they carry only secondary stresses, which are much less than stresses in the members they brace.

Latitude is provided to use the minimum end distances and determine the design bearing stress for this condition. Equations 4.5-1 and 4.5-2 allow one to determine what combination of bearing value and end distance satisfies the engineering and detailing requirements. Equation 4.5-3 places an end distance restriction on thick members such that punching of the holes does not create a possible breakout condition. If the holes are drilled in members where the end distance would be governed by Eq. 4.5-3, this requirement is not necessary. Satisfactory punching of the holes in thick material is dependent on the ductility of the steel, the adequacy of the equipment (capability of the punching equipment and proper mainte-

TABLE C4.1. A394 Bolt Connecting A36 Steel (1 in. = 25.4 mm; 1 ksi = 6.89 MPa; 1 kip = 4,450 N)

Values for end, rolled edge, and center-to-center distances for an A394, type 0, 3/4 in. diameter bolt used in single shear through the threads to connect A36 steel stressed members. Bearing stress = $1.5F_u$

Member Thickness t (in.) (1)	Bearing Stress $1.5F_u$ (ksi) (2)	Force Bolt P (kips) (3)	Eq. 4.5-1 e (in.) (4)	Eq. 4.5-2 e (in.) (5)	Eq. 4.5-3 e (in.) (6)	e_{min} (in.) (7)	Eq. 4.5-5 S_{min} (in.) (8)	Suggested Erection Spacing (in.) (9)	S_{min} (in.) (10)	Eq. 4.5-6 f_{min} (in.) (11)
1/8	87.0	8.16	1.35	0.98	0.50	1.35	1.80	1.67	1.80	1.15
3/16	87.0	12.23	1.35	0.98	0.56	1.35	1.80	1.67	1.80	1.15
1/4	87.0	16.31	1.35	0.98	0.63	1.35	1.80	1.67	1.80	1.15
5/16	87.0	16.65 ^a	1.10	0.98	0.69	1.10	Less	1.67	1.67	0.94
3/8	87.0	16.65 ^a	Less	0.98	0.75	0.98	Than	1.67	1.67	0.83
7/16	87.0	16.65 ^a	Than	0.98	0.81	0.98	Col. 9	1.67	1.67	0.83
1/2	87.0	16.65 ^a	Col. 5	0.98	0.88	0.98		1.67	1.67	0.83
9/16	87.0	16.65 ^a		0.98	0.94	0.98		1.67	1.67	0.83
5/8	87.0	16.65 ^a		0.98	1.00	1.00		1.67	1.67	0.85
11/16	87.0	16.65 ^a		0.98	1.06	1.06		1.67	1.67	0.90
3/4	87.0	16.65 ^a		0.98	1.13	1.13		1.67	1.67	0.96
13/16	87.0	16.65 ^a		0.98	1.19	1.19		1.67	1.67	1.01
7/8	87.0	16.65 ^a		0.98	0.98 ^b	0.98 ^b		1.67	1.67	0.83 ^b
15/16	87.0	16.65 ^a		0.98	0.98 ^b	0.98 ^b		1.67	1.67	0.83 ^b
1	87.0	16.65 ^a		0.98	0.98 ^b	0.98 ^b		1.67	1.67	0.83 ^b

Eq. 4.5-1 = $1.2P/(F_u t)$

Eq. 4.5-2 = $1.3d$

Eq. 4.5.3 = $1 = d/2$

Eq. 4.5-5 = $1.2P/(F_u t) + 0.6d$

Erection = nut c dimension + 0.375

Eq. 4.5-6 = $0.85e_{min}$

Bolt diameter = 0.75 in.

Bolt shear strength = 16.65 kips

Point-to-point nut dimension = 1.3 in.

Member tensile strength (F_u) = 58.0 ksi

^a P limited by single shear strength (through threads) of bolt.

^b t = 13/16 in.; suggested maximum punching thickness (13/16 in. dia. hole in A36 steel). Distance shown is for drilled holes.

nance of punches and dies), the allowed tolerances between the punch and die, and the temperature of the steel. The following guidelines have been used satisfactorily:

- For 36 ksi (248 MPa) yield steel, the thickness of the material should not exceed the hole diameter;
- For 50 ksi (345 MPa) yield steel, the thickness of the material should not exceed the hole diameter minus 1/16 in. (1.6 mm); and
- For 65 ksi (448 MPa) yield steel, the thickness of the material should not exceed the hole diameter minus 1/8 in. (3.2 mm).

Figure C4.1 shows the end distances for an A394, Type O, 3/4 in. (19 mm) diameter bolt used to connect

A36 steel stressed members. The maximum bearing stress of $1.5F_u$ has been used unless shear governs the maximum force in the bolt. Table C4.1 contains the tabulated values for Figure C4.1 and shows that Eq. 4.5-1 governs up through a thickness of 5/16 in. (6.9 mm); Eq. 4.5-2 governs for thicknesses of 3/8 in. (9.5 mm) through 9/16 in. (14.3 mm); and, Eq. 4.5-3 governs thicknesses of 5/8 in. (15.9 mm) and above, unless the holes are drilled. For drilled holes, Eq. 4.5-2 would continue to govern over this range of thicknesses. The range of thicknesses over which each equation governs changes if the bearing stress is reduced below the maximum design bearing stress of $1.5F_u$. Figure C4.2 illustrates the proper application of the required end distance when a member is clipped and the sheared surface is not perpendicular to the primary axes of the member.

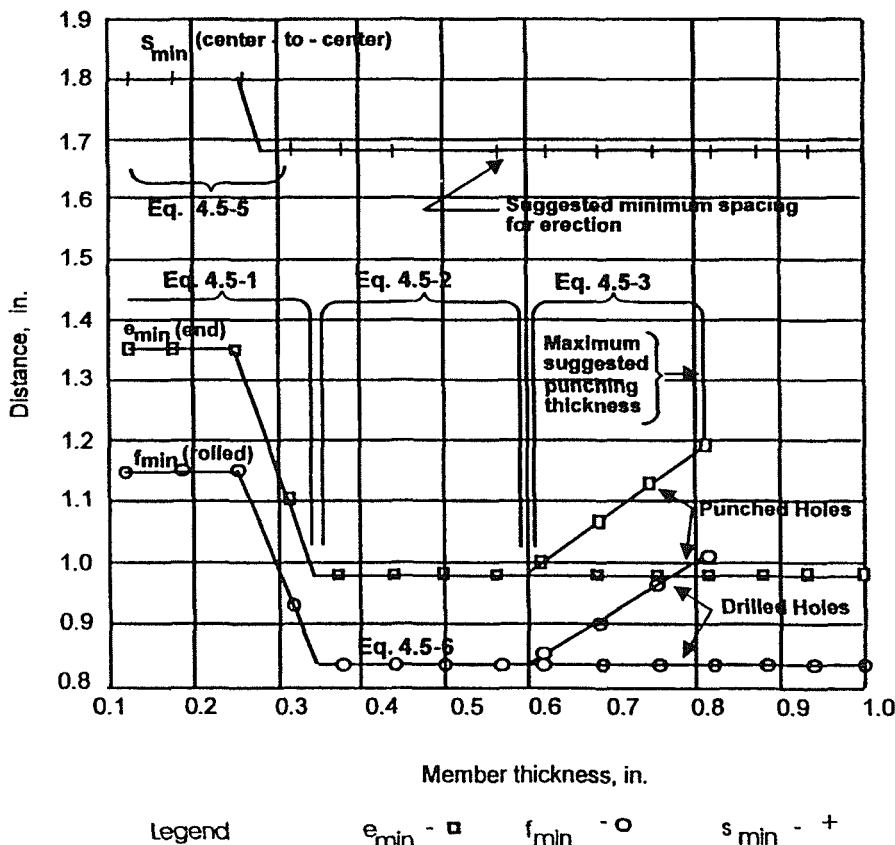

End, rolled edge and center-to-center distances for an A394, Type O, 3/4 in. diameter bolt used to connect A36 stressed steel members. Bolt in single shear (through threads). Bearing stress = $1.5 F_u$

FIGURE C4.1. A394 Bolt Connecting A36 Steel (1 in. = 25.4 mm)

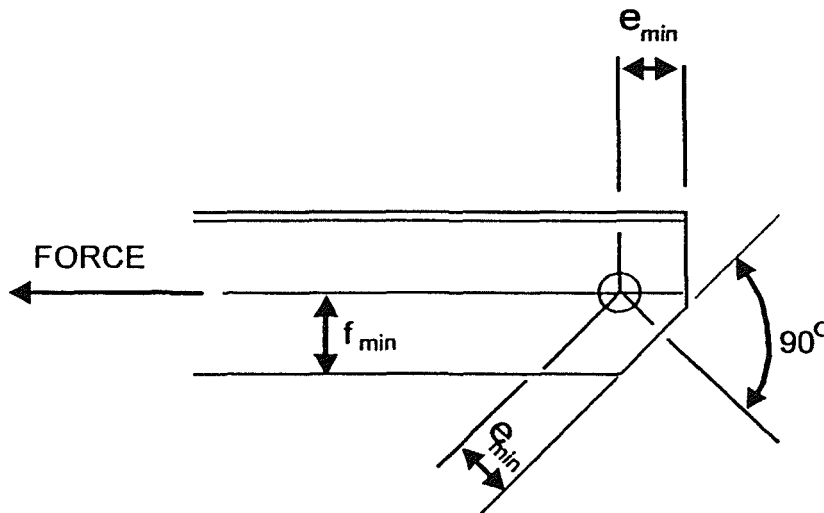

FIGURE C4.2. Application of e_{min} to Clipped Member

C4.5.2 Center-to-Center Bolt Hole Spacing

Two factors must be considered when determining the minimum center-to-center bolt spacing. Equation 4.5-5 is the strength expression for end distance (Eq. 4.5-1) plus 0.6 times the diameter of the adjacent bolt. The term $0.6d$ has been specified instead of the more commonly recognized $0.5d$, to provide greater control over the reduction in center-to-center material due to hole breakout during punching.

For low bearing values, the spacing requirements predicted by Eq. 4.5-5 may be less than the spacing required for installation. Spacing requirements for convenient installation should be determined by adding $3/8$ in. (9.5 mm) to the width across the points of the nut being used. Figure C4.1 and Table C4.1 show that the installation requirement governs for thick members.

C4.5.3 Edge Distance

Several studies have considered the effects of end and edge distance on the strength of connections for stressed members (Bodegom et al. 1984; Kennedy and Sinclair 1969; Gilchrist and Chong 1979). Tests by Bodegom et al. (1984) establish a ratio of the rolled edge distance to the sheared edge distance to prevent a tension tear-out of the rolled edge. Equation 4.5-6 combines the results given in Bodegom et al. (1984) with the minimum end distances in Eq. 4.5-2. The same ratio is retained for determining the relationship between all end distances and the required rolled edge distance. When the edge distance is to a sheared or mechanically guided flame cut edge, $1/16$ in. (1.6 mm) is added to the rolled edge

distance. Figure C4.1 shows the relationship between the rolled edge and end distances.

C4.6 ATTACHMENT HOLES

Oversized holes are commonly used as load attachment points for insulator strings, overhead ground wires, and guys. These holes are not used where connections are designed for load reversal. The possible failure modes considered are bearing, tension and shear. These recommendations do not exclude the use of other attachment holes or slots designed by rational analysis.

Equation 4.6-1 assumes the member will fail in shear with shear planes developing at each side of the bolt through the edge of the member; Figure C4.3 illustrates the various terms used. The equation was developed by replacing e in Eq. 4.5-1 with $(L - 0.5d_h)$, solving for P , and multiplying the result by 0.9. Given that L is defined as the distance from the center to any member edge, the member will always fail in shear before it fails in tension. The dimension L shown for the edge distance, perpendicular to the line of action of P , may be reduced if analysis shows that the sum of the tensile stress P/A and the tensile bending stress does not exceed $0.67F_y$, where F_y is the member yield stress.

Equation 4.6-1 has been limited to hole diameters less than or equal to two bolt diameters. This represents the range of experience over which the equation has been used in practice. No adjustment to Eq. 4.6-1 is required for slight chamfering of the

ponent of the structure, usually before that structure or a structure of similar design is fabricated in quantity.

A traditional proof test is set up to conform to the design conditions; that is, only static loads are applied, the prototype has ideal foundations, and the restraints at the load points are the same as in the design model. This kind of test will verify the adequacy of the members and their connections to withstand the static design loads specified for that structure as an individual entity under controlled conditions. Proof tests can provide insight into actual stress distribution of unique configurations, fit-up verification, action of the structure in deflected positions, adequacy of connections, and other benefits. The test cannot confirm how the structure will react in the transmission line where the loads may be dynamic, the foundations may be less than ideal, and where there is some restraint from intact wires at the load points.

The testing procedures provided in this document are based on performing a proof test using a test station that has facilities to anchor a single prototype to a suitable base, load and monitor pulling lines in the vertical, transverse, and longitudinal directions, and measure deflections.

C6.2 FOUNDATIONS

C6.2.1 General

The type, rigidity, strengths, and moment reactions of the actual attachments of a prototype to a test bed have a major effect on the ability of the prototype members to resist the applied loads; consequently, the reactions of the test foundations should be similar to the expected reactions of the in-service foundations.

C6.2.2 Rigid Structures

Tests of a fairly rigid, four-legged, latticed structure designed for stub angles set in concrete, anchor bolts and base plates on concrete, or earth grillage foundations, are usually performed on special stub angles bolted or welded to the test station's rigid base. Accurate positioning of the footings is necessary to prevent abnormal stresses in the structure members.

C6.2.3 Direct Embedded Structures

It is recommended that structures designed for direct embedment be tested in a two-part program.

C6.2.3.1 Embedded Portion

Soil properties at a permanent test station probably will not match the properties of the soil on the transmission line. Tests that are dependent on soil resistance should be done at the line site, since only load cases that control the anchorage design need be performed.

C6.2.3.2 Above-Ground Portion

The above-ground portion of the prototype should be modified to be bolted or welded to the test station's foundation. All controlling load cases should be applied to this prototype.

C6.2.4 Components

For component tests, especially single members, the amount of rotational rigidity of the supports is critical. All the other parameters of the attachments of the prototype to the test bed must also be as close to the in-service conditions as possible.

C6.3 MATERIAL

Proper interpretation of the data obtained from testing is critical in establishing the true capacity of individual members. There is concern about using members in a prototype that have yield points considerably higher than the minimum guaranteed yield value that is used as the basis for design. The actual yield points of tension members and of compression members with KL/r values less than 120 are critical in determining the member capacity. Consequently, the guidelines shown in Figure C6.1 are suggested as a basis for determining the maximum yield point values for these members of the prototype. All other members of the prototype must conform to the standard material specifications but their actual yield points are not as critical to their load-carrying capabilities.

C6.4 FABRICATION

Normally, the prototype is not galvanized for the test unless the purchaser's order states otherwise.

C6.5 STRAIN MEASUREMENTS

Stress determination methods, primarily strain gauging, may be used to monitor the loads in indi-

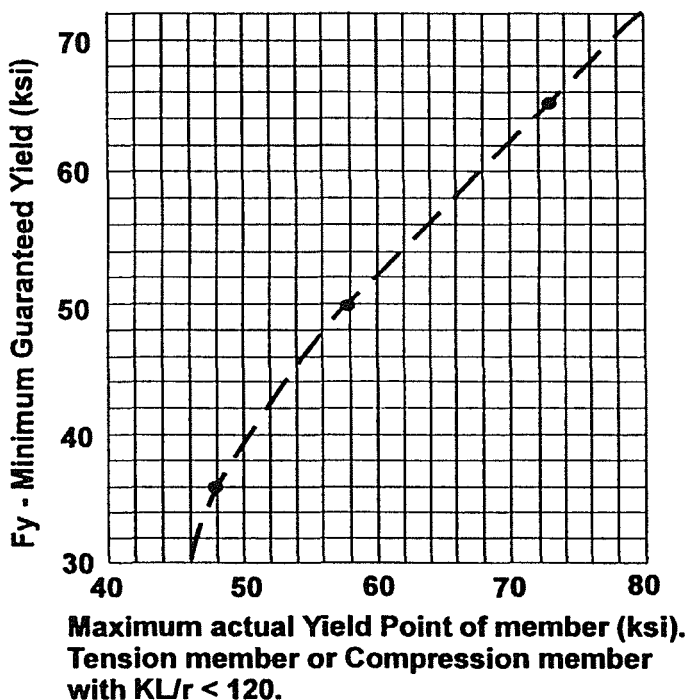

FIGURE C6.1. Maximum Overstrengths for Members of the Prototype (1 ksi = 6.89 MPa)

vidual members during testing. Comparison of the measured unit stress to the predicted unit stress is useful in validating the proof test and refining analysis methods. Care must be exercised when instrumenting with strain gauges, both as to location and number, to assure valid correlation with design stress levels.

C6.6 ASSEMBLY AND ERECTION

The erected prototype shall conform with the special requirements of the purchaser's instructions; many purchasers specify minimum torque for bolt tightening and that the vertical axis shall not be out of plumb by more than 1 in. (25 mm) for every 40 ft. (12 m) of height.

C6.8 LOAD APPLICATION

V-type insulator strings shall be loaded at the point where the insulator strings intersect. If the insulators for the towers in the line are V-type strings

that will not support compression, it is recommended that articulated bars or wire rope slings be used to simulate the insulators. If compression or cantilever insulators are planned for the transmission line, members that simulate those conditions should be used in the test.

Compression on unbraced panels due to bridling of load lines should be avoided.

As a structure deflects under load, load lines may change their direction of pull. Adjustments shall be made in the applied loads or the test rigging shall be offset accordingly so that the vertical, transverse, and longitudinal vectors at the load points are the loads specified in the tower loading schedule.

C6.9 LOADING PROCEDURE

It is recommended that the primary consideration in establishing the sequence of testing should be that those load cases having the least influence on the results of successive tests be tested first. A secondary consideration should be to simplify the operations necessary to carry out the test program.

C6.10 LOAD MEASUREMENT

The effects of pulley friction should be minimized. Load measurement by monitoring the load in a single part of a multipart block and tackle arrangement should be avoided.

C6.11 DEFLECTIONS

Points to be monitored shall be selected to verify the deflections predicted by the design analysis.

C6.13 DISPOSITION OF PROTOTYPE

An undamaged structure is usually accepted for use in the transmission line after all components are visually inspected and found to be structurally sound and within tolerances.

C7.0 STRUCTURAL MEMBERS AND CONNECTIONS USED IN FOUNDATIONS

C7.1 INTRODUCTION

The material in Section 7 covers structural members and connections normally supplied by the steel fabricators.

C7.2 GENERAL CONSIDERATIONS

C7.2.2 Pressed Plates

For the pressed plate foundation, a relatively thick steel plate washer is welded to the bottom of the stub angle. This allows an attachment for bolting to the pressed plate and provides a transfer of the axial load from the stub angle to the corners of the pressed plate.

C7.3 DETERIORATION CONSIDERATIONS

Concrete foundations should be properly sloped to drain so that water pockets do not accumulate with ground material and cause excessive corrosion of the tower base material. If towers are located where ground water can be highly corrosive, such as ash pits, industrial drainage areas, and oil refineries, con-

crete foundations should be used. If steel is exposed to such a ground water environment, special protection is essential. Proper drainage around the steel should be established and periodic inspections conducted. In some cases, it may be necessary to apply an additional protective coating such as a bitumastic compound to the steel. If new towers are located in such an environment, any steel members exposed to this severe ground condition should be increased in thickness at least 1/16 in. (1.6 mm) as a corrosion allowance.

C7.5 DESIGN REQUIREMENTS FOR CONCRETE AND REINFORCING STEEL

ACI 349 requirements for anchorage material have been modified for use in this Standard. The formulas in this Standard use yield strength F_y of the anchorage material and are suitable to ensure a ductile failure of the anchor material prior to a brittle failure of the concrete.

The ACI (1985) *Code Requirements for Nuclear Safety Related Concrete Structures* recommend the following side cover distance for tension to prevent failure due to lateral bursting for smooth anchor bolts.

$$m_t = 0.66d \sqrt{\frac{F_u}{\sqrt{f'_c}}} \quad (C7.5-1)$$

Equation C7.5-1 can be used for stub angles if an equivalent diameter is determined based on the net section of the stub angle; m_t is measured from any portion of the stub angle to the nearest edge of the concrete.

The ACI (1985) *Code Requirements for Nuclear Safety Related Concrete Structures* recommend the following side cover distance for anchorage shear.

$$m_v = 1.8d \sqrt{\frac{F_u}{\sqrt{f'_c}}} \quad (C7.5-2)$$

For anchor bolts with base plates resting on concrete, shear is transmitted from the bolt at the surface forming a concrete wedge. Translation of the wedge under the shear force cannot occur without an upward thrust of the wedge on the base plate. This thrust induces a clamping force, and this mechanism is called shear friction. Therefore, the concrete or grout serves in developing the clamping action. Shear lugs can be

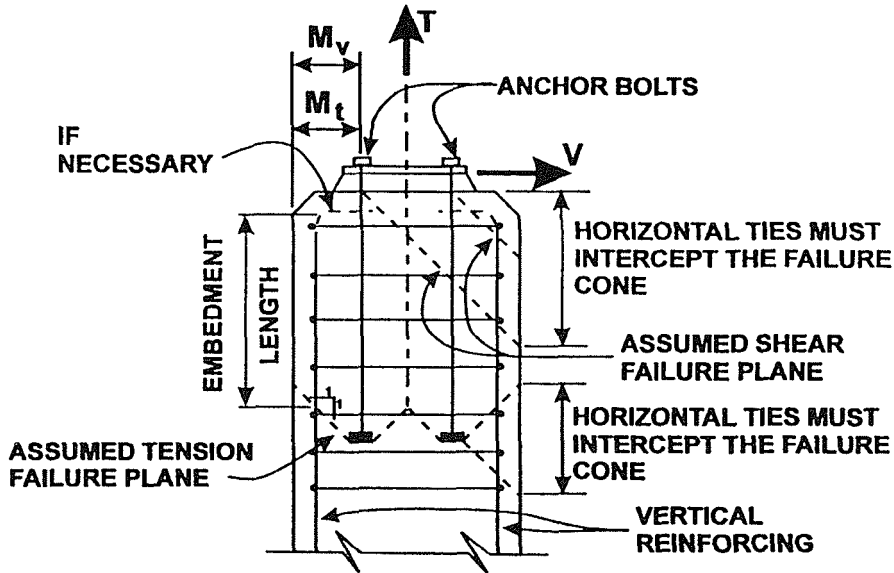

FIGURE C7.1. Pier Reinforcing

used to transfer the shear load to the concrete and should be located in a concrete compression zone unless adequate reinforcing is provided. A combination of shear lugs and shear friction is not permitted.

In determining the side cover distance for shear, the anchor bolt diameter required for shear only can be used in Eq. C7.5-2. However, this distance should not be less than $m_v/3$ determined for the actual d of the anchor bolt used or 4 in.

Equation C7.5-2 can be used for stub angles if an equivalent diameter is determined based on the net section of the angle; m_v is measured from any portion of the stub angle to the nearest edge of the concrete.

Reinforcement as shown in Figure C7.1 assists in containing tension and/or shear blowout. An additional reference is Shipp and Haninger (1983).

C7.6 SHEAR CONNECTORS

C7.6.1 Stud Shear Connectors (See Figure 7.2c)

Additional information is available on stud shear connectors in Salmon and Johnson (1990).

C7.6.2 Angle Shear Connectors (See Figure 7.2b)

The values obtained using Eq. 7.5.2 are based on initial yielding of the angle in bending at a stress of $1.19 f'_c$ in the concrete. The 1.19 constant is based on the concrete pier having an area at least four times as

large as the bearing area of a pair of shear connector angles.

C8.0 QUALITY ASSURANCE/QUALITY CONTROL

C8.1 INTRODUCTION

A well planned and executed quality assurance (QA)/quality control (QC) program is necessary to ensure delivery of acceptable material in a timely manner. The objective of the program is to establish that transmission material is in conformance with the specifications of the purchase contract. A clear and concise contract between purchaser and supplier is an important part of the procedure necessary to obtain acceptable transmission towers. It is helpful if the responsibilities of both the purchaser and the supplier can be defined in the contract so that no part of the process used to purchase, design, detail, test, fabricate, and deliver transmission material is omitted.

The purchaser's QA program outlines the methods, types of inspections, and records that are necessary to provide suitable production controls.

The supplier's QC program is a written document or series of information memoranda that establish procedures and methods of operation that affect the quality of the product. The supplier has complete control over the QC program and modifies it to ad-

just to changing requirements of a particular operation.

A joint review of the QA–QC requirements and agreement by both the purchaser and the supplier will allow for any conflict resolution prior to the ordering of materials. Typical items discussed during the review process are the review and acceptance of the supplier's material specifications, sources of supply, material identification, storage, traceability procedures, and acceptance of certified mill test reports.

C8.2 QUALITY ASSURANCE

A quality assurance program documents the methods followed to establish appropriate review and interface with the supplier's quality control procedures. This will ensure that the contract can proceed smoothly, that proper communication channels are established with the responsible personnel to minimize confusion, that the purchaser's requirements are properly met, and that proper guidance and adequate technical support is provided throughout the period of the contract.

The QA program defines the personnel that have the responsibility for contract performance, engineering, inspection, and receipt of material. Contract performance covers enforcement of the terms of the contract relative to payment, delivery commitments, contract changes, and legal matters. Engineering covers technical matters relative to design adequacy, detail requirements, production controls, structure testing, and shipment of material. Inspection covers the purchaser's material certification and production requirements. This requires a close in-shop relationship with the supplier. In some instances, the pur-

chaser utilizes contract personnel for this activity. Receipt of material by the purchaser's designated representative covers invoice certification that correct material has been received in the field.

As part of the QA program the purchaser or a designated representative may inspect the supplier's equipment and facilities to ensure that the procedures followed during production meet the specific job requirements. The inspection may cover material certification, material handling, cutting and piece mark identification procedures, bending, welding, nondestructive testing required, galvanizing, fit-up requirements, and bundling for shipment.

C8.3 QUALITY CONTROL

The QC program establishes appropriate quality control checks for the supplier's planning and scheduling, engineering, drafting, purchasing, production, and shipping. Planning and scheduling is responsible for assuring that the work proceeds in an orderly manner. Engineering is responsible for specification, design, and shop drawing review in accordance with accepted standards and loading criteria. Drafting covers shop detail drawings that correctly and adequately interpret the design drawings and specification. Purchasing secures appropriate materials and services in accordance with the requirements of the contract drawings and specification. Production is responsible for all fabricating activities, receipt of material, storage, material preparation, processing, marking, welding, galvanizing, assembly, and shipping. The QC program establishes the procedures for determining that the finished product meets the purchaser's allowable tolerances.

REFERENCES

- ACI (1983). *Building Code Requirements for Reinforced Concrete* (with Commentary). ACI Committee 318, Publication No. 318-83 (Revised 1986), American Concrete Institute, Detroit, MI.
- ACI (1985). *Code Requirements for Nuclear Safety Related Concrete Structures*. Appendix B with Commentary. ACI Committee 349, Publication No. 349-85, American Concrete Institute, Detroit, MI.
- Adluri, S.M.R. and Madugula, M.K.S. (1991). *Design Strength of Schifflerized Angle Struts*. American Institute of Steel Construction Engineering Journal, New York.
- AISC (1989a). *Specification for Structural Steel Buildings—Allowable Stress Design and Plastic Design*. American Institute of Steel Construction, Inc., Chicago.
- AISC (1989b). *Manual of Steel Construction, Allowable Stress Design*, 9th ed. American Institute of Steel Construction, Inc., Chicago.
- AISC (1994). *Manual of Steel Construction, Load and Resistance Factor Design*, 2nd ed. American Institute of Steel Construction, Inc., Chicago.
- AISE (1985). *The Making, Shaping, and Treating of Steel*, 10th ed. Association of Iron and Steel Engineers, Pittsburgh, PA.
- AISI (1986). *Specification for the Design of Cold-Formed Steel Structural Members* (with Commentary). American Iron and Steel Institute, Washington, DC.
- AISI (1987). *Cold-Formed Steel Design Manual*. American Iron and Steel Institute, Washington, DC., Part III.
- ASCE (1988). *Guide for Design of Steel Transmission Towers*. Manual no. 52, 2nd ed., Task Committee on Updating Manual 52 of the Struct. Div., ASCE, New York.
- ASCE (1991). *Guidelines for Transmission Line Structural Loading*. Committee on Elect. Trans. Struc. of Committee on Analysis and Design of Struc. of Struc. Div. ASCE, New York.
- ASTM (1999). Standard specification for general requirements for rolled steel plates, shapes, sheet piling, and bars for structural use, designations A 6. In *Annual Book of ASTM Standards*, Section 1, Vol. 01.04, American Society for Testing and Materials, Philadelphia.
- ASTM (1999). Standard specification for zinc-coated steel transmission tower bolts, designation A394. In *Annual Book of ASTM Standards*, Section 15, Vol. 15.08, American Society for Testing and Materials, Philadelphia.
- ATADS (1995). *Advance Tower and Design System*. Bonneville Power Administration, Portland, OR.
- Bodegom, J.V., Evensen, B., and Gidlund, J.I. (1984). *Single Bolt Connections of Angles in Transmission Line Towers*. CIGRE Report, Study Committee 22, Working Group 08, August.
- BPA (1987). *Tower analysis and design*. Bonneville Power Administration, Portland, OR.
- Brockenbrough, R.L. (1983). Considerations in the design of bolted joints for weathering steel. *Engrg. J. Amer. Inst. of Steel Constr.*, 40–45.
- Brockenbrough, R.L. and Schmitt, R.J. (1975). Considerations in the performance of bare high-strength low-alloy steel transmission towers. Paper C 75 041-9, IEEE Power Engrg. Soc., Winter Meeting, New York.
- Carpena, A. and Diana, G. (1971). Behavior to wind action of angle and T-bars on H.V. lattice structures. Paper 71 TP 668-PWR, IEEE Power Engr. Soc., Summer Meeting, Portland, OR.
- Cassarico, G., DePointe, S., and Faggiano, P. (1983). Experimental investigation on the aero-elastic instability of thin walled open sections. *Constr. Metal.*, 1.
- Chesson, E., Faustino, N.L., and Munse, W.H. (1965). High strength bolts subjected to tension and shear. *J. Struct. Div. ASCE*, 91(ST5), 155–180.
- Clark, J.W. and Hill, H.N. (1960). Lateral buckling of beams. *J. Struct. Div., ASCE*, 86(7).
- ETADS (1989). *EPRI TL Workstation*. Vol. 13. Electric Power Research Institute, Palo Alto, CA.
- Gaylord, E.H., Gaylord, C.N., and Stallmeyer, J.E. (1992). *Design of Steel Structures*, 3rd ed. McGraw-Hill, New York.
- Gaylord, E.H. and Wilhoite, G.M. (1985). Transmission towers: Design of cold-formed angles. *J. Struct. Engrg., ASCE*, 111(8), 1810–1825.
- Gilchrist, R.T. and Chong, K.P. (1979). Thin light-gage bolted connections without washers. *J. Struct. Div., ASCE*, 105(ST1), 175–183.
- Higgins, T.R. and Munse, W.H. (1952). How much combined stress can a rivet take? *Eng. News-Rec.*, Dec. 4, 40.
- IEEE (1997). *National Electrical Safety Code*. Amer. Nat. Stand. C2, Inst. of Electr. and Electron. Engr. Inc., New York.

- Johnston, B.G. Ed. (1988). *Guide to Stability Criteria for Metal Structures*, 4th ed. Wiley, New York.
- Kennedy, J.B. and Sinclair, G.R. (1969). Ultimate capacity of single bolted angle connections. *J. Struct. Div., ASCE*, 95(ST8), 1645–1660.
- Kravitz, R.A. (1982). Transmission line tower analysis and design in review. Paper 82 WM 204-6, IEEE Power Engr. Soc., Winter Meeting, New York.
- Kulak, G.L., Fisher, J.W., and Struik, J.H. (1988). *Guide to Design Criteria for Bolted and Riveted Joints*. Wiley, New York.
- Leigh, J., Thomas, B., and Lay, M. (1984). Safe load for laterally unsupported angles. *Amer. Inst. of Steel Const. Engrg. J.*, New York.
- Long, L.W. (1974). Analysis of seismic effects on transmission structures. *IEEE Trans. Power Appar. Sys. PAS-93* (1), 248–254.
- Madugula, M. and Kennedy, J. (1985). *Single and Compound Angle Members*. Elsevier, New York.
- Madugula, M.K.S. and Ray, S.K. (1984). Ultimate strength of eccentrically loaded cold-formed angles. *Can. J. Civ. Engrg.* 11.
- Peyrot, A.H. (1985). Microcomputer based non-linear structural analysis of transmission line systems. *IEEE Trans. Power Appar. Sys. PAS-104* (11).
- Power Line Systems. (1995). *Tower*. Program for the analysis and design of steel latticed transmission towers, Power Line Systems, Madison, WI.
- Prickett, S.L., Mueller, W.H., and Kempner, L., Jr. (1989). Limit state analysis correlated to a full scale tower test. In Proceedings ASCE, Structures Congress (San Francisco).
- Rossow, E.C., Lo, D.L.C., and Chu, S-L. (1975). Efficient design analysis of physically nonlinear trusses. *J. Struct. Div., ASCE*, 101(ST4), 839–853.
- Roy, S., Fang, S-J., and Rossow, E.C. (1984). Secondary stresses on transmission tower structures. *J. Energy Engrg., ASCE*, 110(2), 157–172.
- Salmon, C.G. and Johnson, J.E. (1990). Composite steel—concrete construction. In *Steel Structures, Design and Behavior*, 3rd ed. Harper and Row, New York.
- Shipp, J.G. and Haninger, E.R. (1983). Design of headed anchor bolts. *Amer. Inst. of Steel Constr. Inc. Engrg. J.*
- Timoshenko, S. and Gere, J.M. (1961). *Theory of Elastic Stability*, 2nd ed. McGraw-Hill, New York.
- Wilhoite, G.M. (1985). Bolted connections for steel towers. In *Proceedings of the Conference on Innovations in the Design of Electrical Transmission Structures*, Struct. Div., ASCE (Kansas City, MO Aug.) 79–85.
- Yu, W.W. (1986). *Cold-Formed Steel Structures*. McGraw-Hill, New York.
- Zavelani, A. (1984). Design recommendations for cold-formed sections. Paper presented at ASCE Spring Convention (Atlanta, GA).
- Zavelani, A. and Faggiano, P. (1985). Design of cold-formed lattice transmission towers. *J. Struct. Engrg., ASCE*, 111(11), 2427–2445.

APPENDICES

APPENDIX A NOTATION

The following symbols are used in this Standard:

- A = cross-sectional area (in.²) (mm²)
 A_g = gross cross-sectional area (in.²) (mm²), or gross area of angle, or net area if there is a hole in the angle at the intersecting plane of the concrete foundation and the angle (in.²) (mm²)
 A_n = net cross-sectional area (in.²) (mm²)
 A_s = tensile stress area of bolt (in.²) (mm²)
 A_{sc} = cross-sectional area of stud shear connector (in.²) (mm²)
 A_t = minimum net area in tension (in.²) (mm²); or, minimum net area in tension from the hole to the toe of the angle perpendicular to the line of force (in.²) (mm²)
 A_v = minimum net area in shear (in.²) (mm²)
 a = distance from shear center to load plane (in.) (mm)
 b, b_1, b_2 = effective design widths of elements (in.) (mm), or width of leg $-t/2$ (in.) (mm)
 C = constant based on ratio of f_1 and f_2
 C_b = coefficient in formula for design bending stress
 C_c = column slenderness ratio separating elastic and inelastic buckling
 C_m = coefficient applied to bending term in interaction formula for prismatic members
 C_w = warping constant of cross-section (in.⁶) (mm⁶)
 D = downthrust load; net difference in compression and uplift reactions on anchor bolts (kips) (N)
 d = nominal diameter of bolt (in.) (mm), or minimum depth of stiffener (in.) (mm)
 d_h = diameter of attachment hole (in.) (mm)
 E = modulus of elasticity of steel (29,000 ksi) (200,000 MPa)
 E_c = modulus of elasticity of concrete (ksi) (MPa)
 e = distance from center of hole to end of member (in.) (mm)
 e_m = required distance from center of hole to end of member (in.) (mm)
 F_a = design axial compressive stress in prismatic member in absence of bending moment (ksi) (MPa)
 F_b = design bending stress in prismatic member in absence of axial force (ksi) (MPa)
 F_{cr} = critical stress for local buckling of plain angle members (ksi) (MPa)
 F_t = design axial tensile stress (ksi) (MPa)
 $F_{t(v)}$ = design axial tensile stress in conjunction with shear stress (ksi) (MPa)
 F_u = specified minimum tensile strength (ksi) (MPa)
 F_v = design shear stress (ksi) (MPa), or design average shear stress for beam webs (ksi) (MPa)
 F_y = specified minimum yield stress (ksi) (MPa)
 f = stress in compression element computed on the basis of effective design width (ksi) (MPa); distance from center of hole to edge of member (in.) (mm)
 f_1, f_2 = stress, in tension or compression, on an element (ksi) (MPa)
 f'_c = specified compressive strength of concrete at 28 days (ksi) (MPa)
 f_m = required distance from center of hole to edge of member (in.) (mm)
 f_v = computed shear stress (ksi) (MPa)
 g = transverse spacing locating fastener gauge lines (in.) (mm)
 h = clear distance between flanges of beam (in.) (mm)
 I = moment of inertia in truss plane (in.⁴) (mm⁴)
 I_{ps} = polar moment of inertia about shear center (in.⁴) (mm⁴)
 I_u = moment of inertia about $U-U$ axis (in.⁴) (mm⁴)
 I_x = moment of inertia about $X-X$ axis (in.⁴) (mm⁴)
 I_y = moment of inertia about $Y-Y$ axis (in.⁴) (mm⁴)
 I_z = moment of inertia about $Z-Z$ axis (in.⁴) (mm⁴)
 J = torsional constant of cross section (in.⁴) (mm⁴)
 j = section property for torsional-flexural buckling (in.) (mm)

- K = effective length factor for prismatic member
 K_r = effective length factor for warping and rotation
 K_u, K_x, K_y = effective length factor for buckling in designated axis
 K' = effective length factor for a member with varying load and equal subpanel unsupported lengths
 L = unbraced length of column (in.) (mm), distance from center of attachment hole to member edge (in.) (mm)
 L_x, L_y = unbraced length in designated axis (in.) (mm)
 L' = equivalent unsupported length of a member with varying load and equal length subpanels (in.) (mm)
 M_{ax} = allowable bending moment about $X-X$ axis (in.-kip) (mm-N)
 M_{ay} = allowable bending moment about $Y-Y$ axis (in.-kip) (mm-N)
 M_b = lateral buckling moment for angles (in.-kip) (mm-N)
 M_c = elastic critical moment (in.-kip) (mm-N)
 M_x = bending moment about $X-X$ axis (in.-kip) (mm-N)
 M_y = bending moment about $Y-Y$ axis (in.-kip) (mm-N)
 M_{yc} = moment causing yield at extreme fiber in compression (in.-kip) (mm-N)
 M_{yt} = moment causing yield at extreme fiber in tension (in.-kip) (mm-N)
 M_1 = smaller moment at end of unbraced length of beam column (in.-kip) (mm-N)
 M_2 = larger moment at end of unbraced length of beam column (in.-kip) (mm-N)
 n = number of threads per unit of length (in.) (mm)
 P = capacity of angle shear connector (kips) (N), axial tension or compression load on member (kips) (N), force transmitted by a bolt (kips) (N)
 P_a = design axial compression load on member (kips) (N)
 P_{ex} = Euler buckling load in $X-X$ axis (kips) (N)
 P_{ey} = Euler buckling load in $Y-Y$ axis (kips) (N)
- Q_n = capacity of a shear connector (kips) (N)
 r = governing radius of gyration (in.) (mm)
 r_{ps} = polar radius of gyration about shear center (in.) (mm)
 r_t = equivalent radius of gyration for torsional buckling (in.) (mm)
 r_{tf} = equivalent radius of gyration for torsional-flexural buckling (in.) (mm)
 r_u = radius of gyration for $U-U$ axis (in.) (mm)
 r_x = radius of gyration for $X-X$ axis (in.) (mm)
 r_y = radius of gyration for $Y-Y$ axis (in.) (mm)
 r_z = radius of gyration for $Z-Z$ axis (in.) (mm)
 S_u, S_x, S_y, S_z = elastic section modulus in designated axis (in.³) (mm³)
 S_{xc} = elastic section modulus about $X-X$ axis of compression flange (in.³) (mm³)
 s = longitudinal center-to-center spacing (pitch) of any two consecutive holes (in.) (mm)
 s_m = required spacing between centers of adjacent holes (in.) (mm)
 T = axial tensile load on anchor bolts (kips) (N)
 t = thickness of element (in.) (mm)
 u = $U-U$ axis designation
 u_o = distance between shear center and centroid (in.) (mm)
 V = shear load perpendicular to anchor material or parallel to the intersecting plane (kips) (N)
 V, V_1, V_2 = shear in a single-angle beam (kips) (N)
 w = flat-width of element (in.) (mm)
 w_s = flat-width of edge stiffener (in.) (mm)
 x = $X-X$ axis designation
 y = $Y-Y$ axis designation
 y_o = distance between shear center and centroid (in.) (mm)
 z = $Z-Z$ axis designation
 α = angle between bracing member and supported members (degrees)
 θ = angle between flange and stiffener lip, angle between load and z -axis (degrees)
 μ = coefficient of friction
 ϕ = resistance factor
 Ψ = unit factor as specified in text

**APPENDIX B
EXAMPLES**

The following examples have been included to illustrate many of the requirements of the Standard. These examples are not intended to represent all the requirements of the Standard and should not be used without first securing competent advice with respect to their suitability for any given application. As stated in Section 3.16, design values other than those illustrated in these examples may be used if substantiated by experimental or analytical investigation.

EXAMPLE 1. Equal Leg Angle with Symmetrical Bracing (1 in. = 25.4 mm; 1 ksi = 6.89 MPa; 1 kip = 4,450 N)

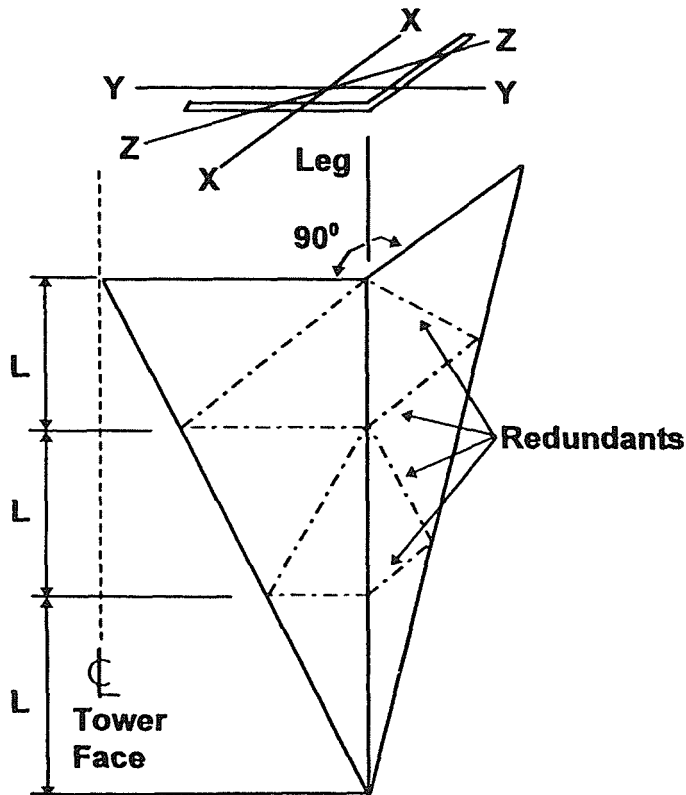

Leg Requirements:

L/r_{zz} critical factor, Concentric loading, Eq. 3.7-4.

Eccentricities at leg splices should be minimized.

Thicker leg sections should be properly butt-spliced.

This method of support minimizes rolling of the angle under load.

$$L8 \times 8 \times 9/16; w/t = 12.1; r_{zz} = 1.59 \text{ in.}; r_{xx} = r_{yy} = 2.50 \text{ in.}; A = 8.68 \text{ in.}^2$$

For 36 ksi yield steel; $w/t_{lim} = 80/\sqrt{36} = 13.3$; $L = 121 \text{ in.}$;

$$L/r_{zz} = 121/1.59 = 76; F_y = 36 \text{ ksi.}$$

From Eq. 3.6-1, $F_a = 29.5 \text{ ksi}$; Design strength = $29.5 \times 8.68 = 256 \text{ kips}$.

$$L8 \times 8 \times 9/16; w/t = 12.1; r_{zz} = 1.59 \text{ in.}; r_{xx} = r_{yy} = 2.50 \text{ in.}; A = 8.68 \text{ in.}^2$$

For 36 ksi yield steel; $w/t_{lim} = 13.3$; $L = 238 \text{ in.}$;

$$L/r_{zz} = 238/1.59 = 150; F_y = 36 \text{ ksi.}$$

From Eq. 3.6-2, $F_a = 12.7$ ksi; Design strength = $12.7 \times 8.68 = 110$ kips.

$$L6 \times 6 \times 5/16; w/t = 16.6; r_{zz} = 1.20 \text{ in.}; r_{xx} = r_{yy} = 1.89 \text{ in.}; A = 3.65 \text{ in.}^2$$

For 36 ksi yield steel; $w/t_{lim} = 13.3$; $F_{cr} = 30$ ksi; $L = 180$ in.;

$$L/r_{zz} = 180/1.20 = 150.$$

From Eq. 3.6-2, $F_a = 12.7$ ksi; Design strength = $12.7 \times 3.65 = 46.4$ kips.

$$L8 \times 8 \times 9/16; w/t = 12.1; r_{zz} = 1.59 \text{ in.}; r_{xx} = r_{yy} = 2.50 \text{ in.}; A = 8.68 \text{ in.}^2$$

For 50 ksi yield steel; $w/t_{lim} = 11.3$; $F_{cr} = 47.6$ ksi; $L = 121$ in.;

$$L/r_{zz} = 76.$$

From Eq. 3.6-1, $F_a = 35.6$ ksi; Design strength = $35.6 \times 8.68 = 309$ kips.

$$L8 \times 8 \times 9/16 \text{ except } L = 238 \text{ in.}; L/r_{zz} = 150.$$

From Eq. 3.6-2, $F_a = 12.7$ ksi; Design strength = $12.7 \times 8.68 = 110$ kips.

EXAMPLE 2. Effect of End Connections on Member Capacity (1 in. = 25.4 mm; 1 ksi = 6.89 MPa; 1 kip = 4,450 N)

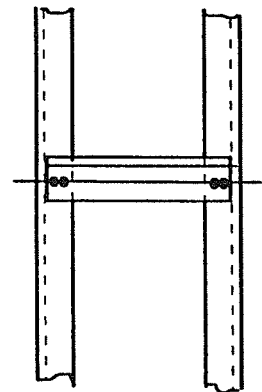
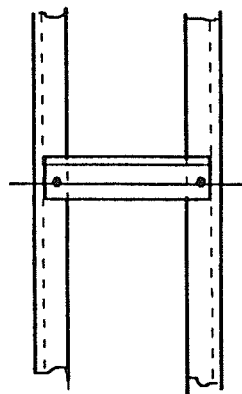
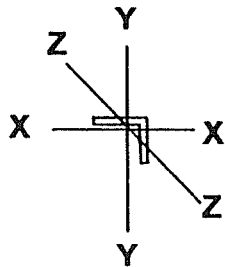
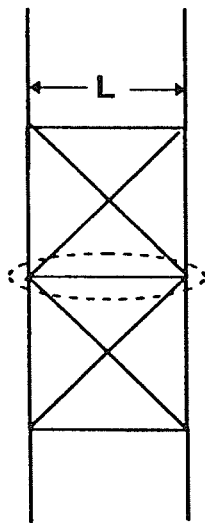

Tension-Only System with Compression Struts.

L/r_{zz} = Critical Factor
Eccentricity in critical axis
 L/r_{zz} = from 0 to 120
(Eq. 3.7-7).

$$L1-3/4 \times 1-1/4 \times 3/16.$$

$r_{zz} = 0.27$ in.; $A = 0.53$ in.²
36 ksi yield steel.

$L = 32$ in.; $L/r_{zz} = 32/0.27 = 119$; (Eqs. 3.7-7 and 3.6-1)
 $F_a = 19.8$ ksi; Design strength = $19.8 \times 0.53 = 10.5$ kips.

Single Bolt Connection; No Restraint at Ends.

L/r_{zz} = from 120 to 250 (Eq. 3.7-8).

$L = 54$ in.; $L/r_{zz} = 54/0.27 = 200$
(Eqs. 3.7-8 and 3.6-2).

$F_a = 7.2$ ksi; Design strength = $7.2 \times 0.53 = 3.8$ kips.

Multiple Bolt Connection; Partial Restraint at Both Ends.

L/r_{zz} = from 120 to 250 (Eq. 3.7-10).

$L = 54$ in.; $L/r_{zz} = 200$ (Eqs. 3.7-10 and 3.6-2).

$F_a = 10.0$ ksi; Design strength = $10.0 \times 0.53 = 5.3$ kips.

EXAMPLE 3. Concentric Loading, Two Angle Member (1 in. = 25.4 mm; 1 ksi = 6.89 MPa; 1 kip = 4,450 N)

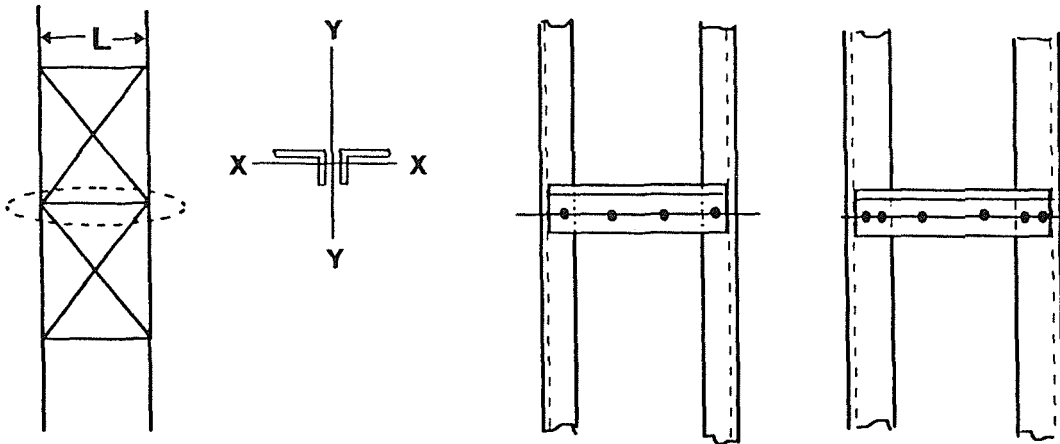

Tension-Only System with Compression Struts.

L/r_{xx} or L/r_{yy} = Critical Factor Concentric Loading.

L/r_{xx} or L/r_{yy} = from 0 to 120 (Eq. 3.7-5).

Single Bolt Connections; No Restraint at Ends.

L/r_{xx} or L/r_{yy} = from 120 to 200 (Eq. 5.7-8).

Multiple Bolt Connections; Partial Restraint at Both Ends.

L/r_{xx} or L/r_{yy} = from 120 to 250 (Eq. 5.7-10).

EXAMPLE 4. K-Bracing, Two Angle Member (1 in. = 25.4 mm; 1 ksi = 6.89 MPa; 1 kip = 4,450 N)

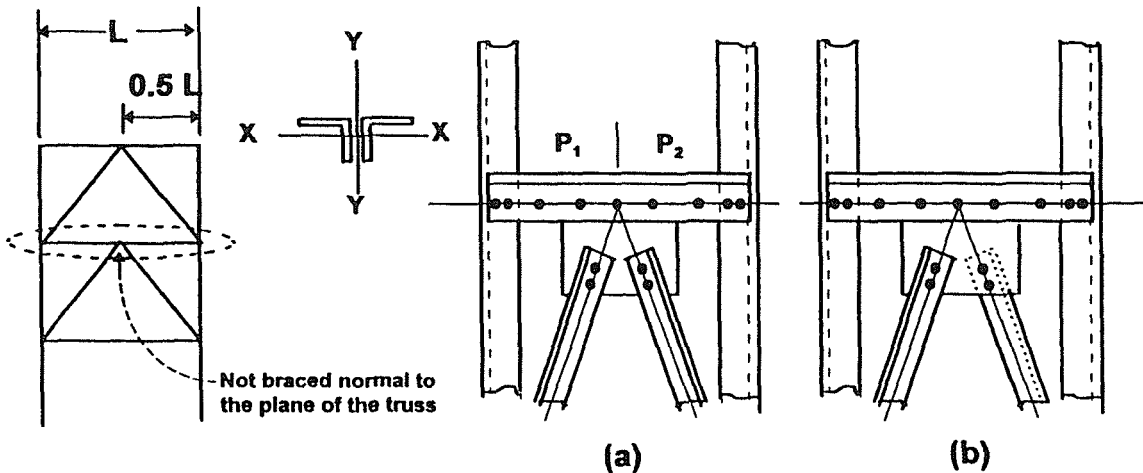

Bracing Requirements

Tension-Compression System with Compression Struts.

Concentric Load at Ends, Eccentric Loading at Intermediate in Both Directions, (a).

Concentric Loading at Ends and Intermediate, (b).

Constant Load ($P_1 = P_2$) in Double Angle

Multiple bolt connections

 $0.5L/r_{xx}$ or L/r_{yy} Critical Factor. $0.5L/r_{xx}$ (Eq. 3.7-6) or L/r_{yy} (Eq. 3.7-5)
from 0 to 120. $0.5L/r_{xx}$ or L/r_{yy} from 0 to 120
(Eq. 3.7-5).

Partial restraint at one end.

 $0.5L/r_{xx}$ from 120 to 225 (Eq. 3.7-9).

See Statement in Section C3.7.4(c).

Partial restraint at both ends.

 L/r_{yy} from 120 to 250 (Eq. 3.7-10).Varying Load (P_1 not equal to P_2) in Equal Length Subpanel of Double AngleCheck member for forces P_1 and P_2 for in-plane buckling using $0.5L/r_{xx}$, as given previously.Check out-of-plane buckling on the y-y axis of the angle over the length L , as follows. $KL/r_{yy} = K(K'L/r_{yy})$ where K' shall be determined from:

1. When
- P_1
- and
- P_2
- are compression forces use Eq. 3.7-15a

$$K' = 0.75 + 0.25 (P_2/P_1), \text{ where } P_1 > P_2$$

Sample Calculation: Assuming $P_1 = -5.6$ kips, $P_2 = -3.3$ kips and concentric loads

$$K' = 0.75 + 0.25 (3.3/5.6) = 0.90.$$

2. When either
- P_1
- or
- P_2
- is a tension force use Eq. 3.7-15b

$$K' = 0.75 - 0.25 (P_2/P_1), \text{ where } P_2 \text{ is the tension force}$$

Sample Calculation: Assuming $P_1 = -44.6$ kips, $P_2 = 2.2$ kips and concentric loads. Note: The negative sign in Eq. 3.7-15b accounts for the different (-) compression and (+) tension forces. Therefore, the absolute magnitude of the forces shall be substituted into the equation.

$$K' = 0.75 - 0.25 (2.2/44.6) = 0.74.$$

The following example is given to demonstrate the situation when eccentric loading exists. Therefore, the preceding figure does not represent the following information.

For members with eccentric loading the K' previously determined should be adjusted using Eq. 3.7-7.*Sample Calculation:* Assuming (2) in the preceding and changing the double angle to a single angle with normal framing eccentricity at both ends; $L = 9.0$ ft., $r_{yy} = 1.38$.Equivalent unsupported length = $K'L = L' = (0.74)(9.0) = 6.66$ ft; $L'/r_{yy} = (6.66)(12)/(1.38) = 57.9$.Using Eq. 3.7-7, $KL'/r_{yy} = 60 + 0.5 (57.9) = 89$.

EXAMPLE 5. Effect of Subdivided Panels and End Connections (1 in. = 25.4 mm; 1 ksi = 6.89 MPa; 1 kip = 4,450 N)

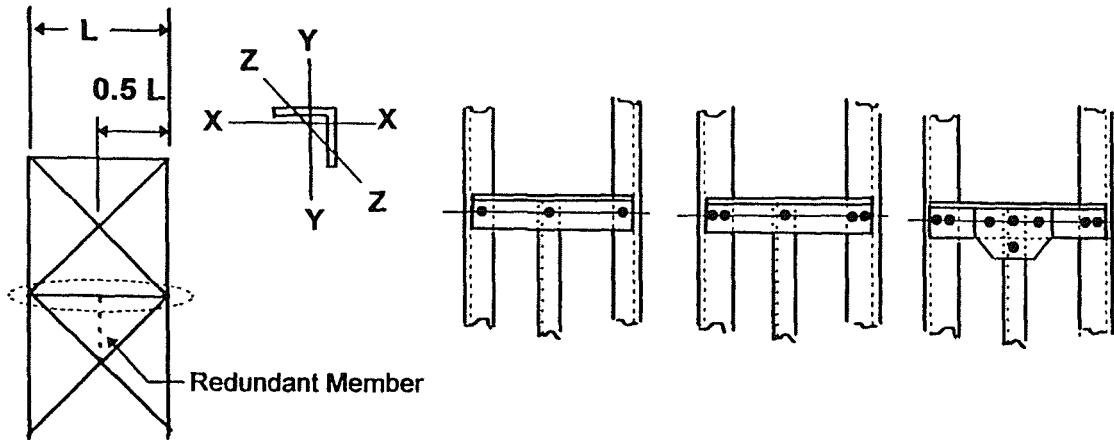

Tension-Only System with Compression Struts.

Single Bolt Connection; No Restraint at Ends or Intermediate.

Multiple Bolt Connection at Ends; Single Bolt Connection at Intermediate Point. Partial Restraint at One End. No Restraint at Intermediate.

Multiple Bolt Connection; Partial Restraint at Ends and Intermediate.

$0.5L/r_z$ or L/r_y critical factor. Eccentricity in critical axis.

$0.5L/r_z$ (Eq. 3.7-6) or L/r_y (Eq. 3.7-7) from 0 to 120.

$L1-3/4 \times 1-1/4 \times 3/16$
 $r_z = 0.27$ in.; $r_y = 0.37$ in.
 $A = 0.53$ in.²
 36 ksi yield steel.

L/r_y , critical: $L = 44$ in.;
 $L/r_y = 44/0.37 = 119$ (Eqs. 3.7-7 and 3.6-1).
 $F_a = 19.8$ ksi.
 Design strength = $19.8 \times 0.53 = 10.5$ kips.

$0.5L/r_z$ or L/r_y from 120 to 200 (Eq. 3.7-8).

$L/r_y = 74/0.37 = 200$ (Eqs. 3.7-8 and 3.6-2).
 Design strength = $7.2 \times 0.53 = 3.8$ kips.

$0.5L/r_z$ from 120 to 225 (Eq. 3.7-9).

L/r_y from 120 to 250 (Eq. 5.7-10).
 $L/r_y = 200$ (Eqs. 3.7-10 and 3.6-2).
 Design strength = $10.0 \times 0.53 = 5.3$ kips.

$0.5L/r_z$ or L/r_y from 120 to 250 (Eq. 3.7-10).

$L/r_y = 200$ (Eqs. 3.7-10 and 3.6-2).
 Design strength = $10.0 \times 0.53 = 5.3$ kips.

Partial restraint at both ends.

EXAMPLE 6. Concentric Loading, Two Angle Member, Subdivided Panels (1 in. = 25.4 mm; 1 ksi = 6.89 MPa; 1 kip = 4,450 N)

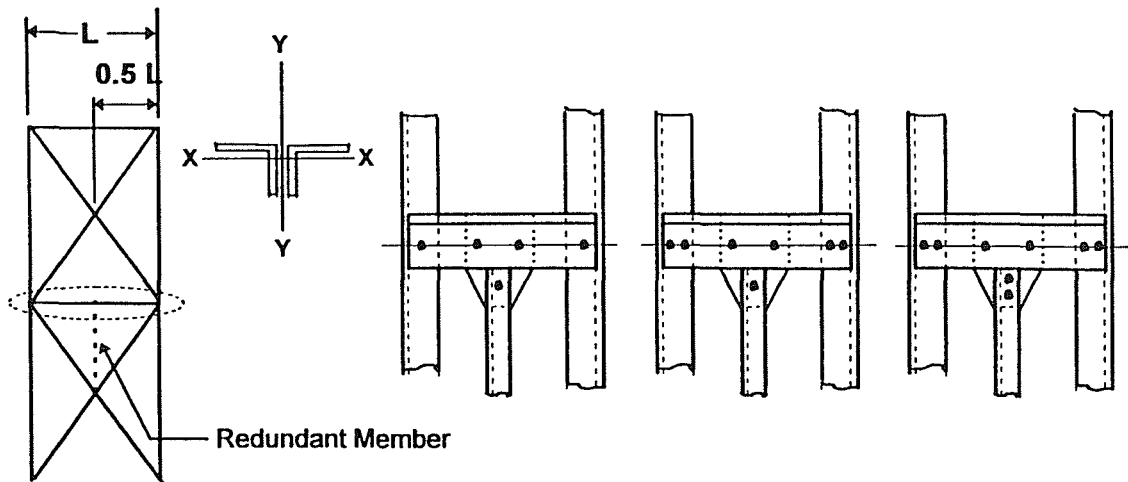

Bracing Requirements

<p>Tension-Only System with Compression Struts.</p>	<p>Single Bolt Connection; No Restraint at Ends or Intermediate.</p>	<p>Multiple Bolt Connection at Ends; Single Bolt Connection at Intermediate Point. Partial Restraint at One End. No Restraint at Intermediate.</p>	<p>Multiple Bolt Connection; Partial Restraint at Both Ends and at Intermediate.</p>
--	---	---	---

See statement in Section C3.7.4 concerning partial restraint.

<p>$0.5L/r_{xx}$ or L/r_{yy} critical factor. Concentric loading $0.5L/r_{xx}$ or L/r_{yy} from 0 to 120 (Eq. 3.7-5).</p>	<p>$0.5L/r_{xx}$ or L/r_{yy} from 120 to 200 (Eq. 3.7-8).</p>	<p>$0.5L/r_{xx}$ from 120 to 225 (Eq. 3.7-9).</p>	<p>$0.5L/r_{xx}$ or L/r_{yy} from 120 to 250 (Eq. 3.7-10).</p>
---	---	--	--

Partial restraint at both ends.

L/r_{yy} from 120 to 250 (Eq. 3.7-10).

EXAMPLE 7. X-Brace Systems with No Intermediate Redundant Support (1 in. = 25.4 mm; 1 ksi = 6.89 MPa; 1 kip = 4,450 N)

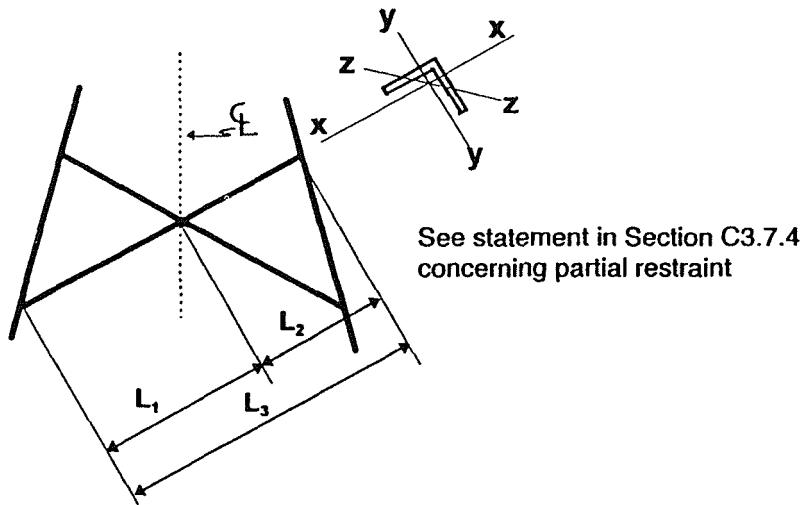

1. Tension/Compression system with members connected at the crossover point. If the member in tension has a force of not less than 20% of the force in the compression member, the crossover point provides support resisting out-of-plane buckling.

$$L_1 \geq L_2$$

For L/r from 0 to 120.

Critical factor L_1/r_{zz} . Use Eq. 3.7-6.

For L/r from 120 to 200.

Critical factor L_1/r_{zz} .

For single bolt connections at the post leg use Eq. 3.7-8.

For multiple bolt connections at the post leg use Eq. 3.7-9.

Providing end restraint can be assumed at the post leg; otherwise use Eq. 3.7-8.

Note: When unequal legs are used and the long leg is connected, the critical factor for out-of-plane buckling should be $(L_1 + 0.5L_2)/r_{yy}$ using the appropriate equation for KL/r as given previously.

2. Tension/Compression system with members connected at the crossover point. If the member in tension has a force of less than 20% of the force in the compression member, or if both members in the same panel are in compression, the crossover point does not provide support resisting out-of-plane buckling.

$$L_1 \geq L_2$$

For L/r from 0 to 120.

Critical factor L_1/r_{zz} . Use Eq. 3.7-6.

Critical factor $L_3/r_{xx \text{ or } yy}$. Use Eq. 3.7-7.

For L/r from 120 to 200.

(a) Critical factor L_1/r_{zz} .

For single bolt connections at the post leg use Eq. 3.7-8.

For multiple bolt connections at the post leg use Eq. 3.7-9.

Providing end restraint can be assumed at the post leg; otherwise use Eq. 3.7-8.

(b) Critical factor $L_3/r_{xx \text{ or } yy}$.

For single bolt connections at the post leg use Eq. 3.7-8.

For multiple bolt connections at the post leg use Eq. 3.7-10.

Providing end restraint can be assumed at the post leg; otherwise use Eq. 3.7-8.

Note: When unequal legs are used and the long leg is connected, the critical factor for out-of-plane buckling should be L_3/r_{yy} , using the appropriate equation for KL/r as given previously.

EXAMPLE 8. X-Brace Systems with Intermediate Redundant Support—Case 1. (1 in. = 25.4 mm; 1 ksi = 6.89 MPa; 1 kip = 4,450 N)

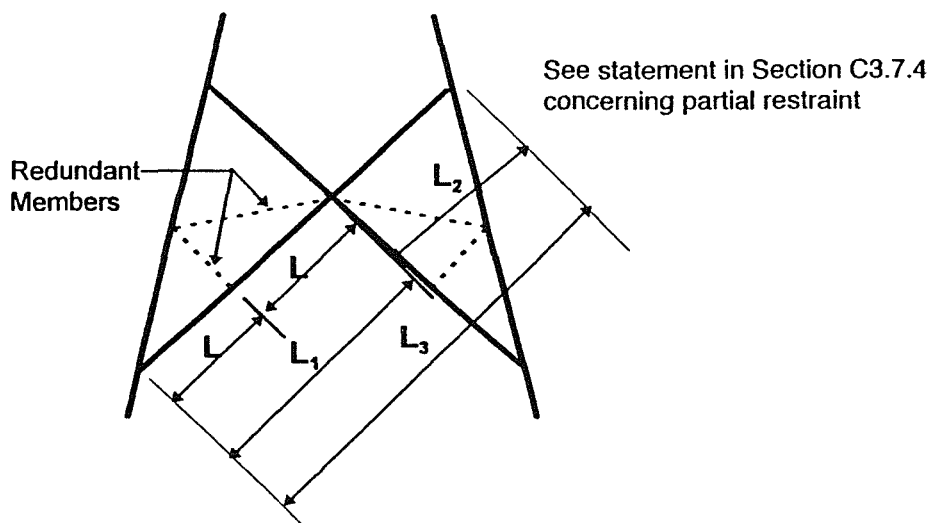

1. Tension/Compression system with members connected at the crossover point. If the member in tension has a force of not less than 20% of the force in the compression member, the crossover point provides support resisting out-of-plane buckling.

$$L_1 > L_2$$

For L/r from 0 to 120.

Critical factor L/r_z or L_2/r_z whichever is maximum. Use Eq. 3.7-6.

Critical factor $L_1/r_{xx \text{ or } yy}$. Use Eq. 3.7-6.

For L/r from 120 to 200.

- (a) Critical factor L/r_z . Use Eq. 3.7-8; or L_2/r_z using Eq. 3.7-9 if end restraint can be assumed; otherwise use Eq. 3.7-8.

- (b) Critical factor $L_1/r_{xx \text{ or } yy}$.

For single bolt connections. Use Eq. 3.7-8.

For multiple bolt connection where end restraint can be assumed at one end, use Eq. 3.7-9; otherwise use Eq. 3.7-8.

No end restraint is assumed in segment between crossover point and intermediate redundant support point.

Note: When unequal legs are used and the long leg is connected the critical factor for out-of-plane buckling should be $(L_1 + 0.5L_2)/r_{yy}$ using the appropriate equation for KL/r as given previously.

2. Tension/Compression system with members connected at the crossover point. If the member in tension has a force of less than 20% of the force in the compression member, or if both members at the same panel are in compression, the crossover does not provide support resisting out-of-plane buckling.

$$L_1 > L_2$$

For L/r from 0 to 120.

Critical factor L/r_z or L_2/r_z whichever is maximum. Use Eq. 3.7-6.

Critical factor $L_3/r_{xx \text{ or } yy}$. Use Eq. 3.7-7.

DESIGN OF LATTICED STEEL TRANSMISSION STRUCTURES

For L/r from 120 to 200.

(a) Critical factor L/r_{zz} . Use Eq. 3.7-8; or L_2/r_{zz} using Eq. 3.7-9 if end restraint can be assumed; otherwise use Eq. 3.7-8.

(b) Critical factor $L_3/r_{xx \text{ or } yy}$.

For single bolt connections at the post legs use Eq. 3.7-8.

For multiple bolt connections at the post legs use Eq. 3.7-10 if end restraint can be assumed at the post leg; otherwise use Eq. 3.7-8.

No end restraint is assumed in the segment between crossover point and intermediate redundant support point.

EXAMPLE 9. X-Brace Systems with Intermediate Redundant Support—Case 2. (1 in. = 25.4 mm; 1 ksi = 6.89 MPa; 1 kip = 4,450 N)

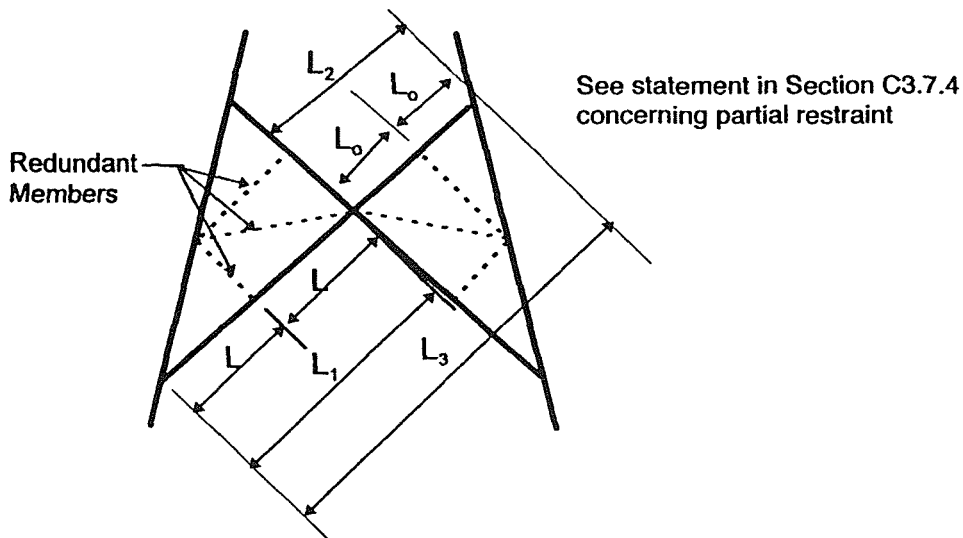

1. Tension/Compression system with members connected at the crossover point. If the member in tension has a force of not less than 20% of the force in the compression member, the crossover point provides support resisting out-of-plane buckling.

$$L_1 \geq L_2 \text{ and } L > L_0$$

For L/r from 0 to 120.

Critical factor L/r_{zz} . Use Eq. 3.7-6.

Critical factor $L_1/r_{xx \text{ or } yy}$. Use Eq. 3.7-6.

For L/r from 120 to 200.

(a) Critical factor L/r_{zz} . Use Eq. 3.7-8.

(b) Critical factor $L_1/r_{xx \text{ or } yy}$.

For single bolt connections. Use Eq. 3.7-8.

For multiple bolt connection where end restraint can be assumed at one end use Eq. 3.7-9; otherwise use Eq. 3.7-8.

No end restraint is assumed in segment between crossover point and intermediate redundant support point.

Note: When unequal legs are used and the long leg is connected the critical factor for out-of-plane buckling should be $(L_1 + 0.5L_2)/r_{yy}$ using the appropriate equation for KL/r as given previously.

2. Tension/Compression system with members connected at the crossover point. If the member in tension has a force of less than 20% of the force in the compression member, or if both members at the same panel are in compression, the crossover does not provide support resisting out-of-plane buckling.

$$L_1 > L_2 \text{ and } L > L_o$$

For L/r from 0 to 120.

Critical factor L/r_{zz} or $L_1/r_{xx \text{ or } yy}$ whichever is maximum. Use Eq. 3.7-6.

Critical factor $L_3/r_{xx \text{ or } yy}$. Use Eq. 3.7-7.

For L/r from 120 to 200.

(a) Critical factor L/r_{zz} . Use Eq. 3.7-8.

(b) Critical factor $L_3/r_{xx \text{ or } yy}$.

For single bolt connections. Use Eq. 3.7-8.

For multiple bolt connection at the post legs use Eq. 3.7-10 if end restraint can be assumed at the post leg; otherwise use Eq. 3.7-8.

No end restraint is assumed in the segment between the crossover point and intermediate redundant support point.

Note: When unequal legs are used and the long leg is connected the critical factor for out-of-plane buckling should be L_3/r_{yy} using the appropriate equation for KL/r as given previously.

EXAMPLE 10. Cold-Formed Angle (1 in. = 25.4 mm; 1 ksi = 6.89 MPa; 1 kip = 4,450 N)

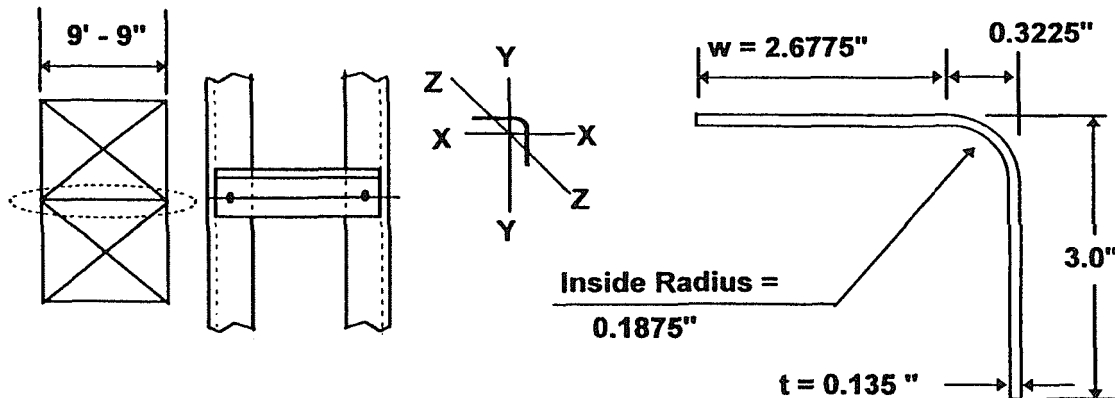

Tension-Only System with Compression Strut

$F_y = 50 \text{ ksi.}$

$C_c = 106.9; r_{zz} = 0.586 \text{ in.; Area} = 0.777 \text{ in.}^2, L = 117 \text{ in.}$

$w/t = 2.6775/0.135 = 19.8; w/t_{lim} = 80/\sqrt{F_y} = 11.3; w/t = 144/\sqrt{F_y} = 20.4; 11.3 < 19.8 < 20.4.$

Then $F_{cr} = (1.677 - 0.677 \times 19.8/11.3)50 = 24.6 \text{ ksi; and } C_c = \pi\sqrt{2E/F_{cr}} = 3.14 \sqrt{\frac{2(29,000)}{24.6}} = 152.5.$

For a single bolt connection: $L/r_{zz} = 117/0.586 = 200 > C_c$

$K = 1 \text{ (Eq. 3.7-8); Design Strength} = F_a \times A = \frac{286,000}{(200)^2} \times 0.777 = 5.6 \text{ kips.}$

DESIGN OF LATTICED STEEL TRANSMISSION STRUCTURES

For a two bolt connection: $L/r_{zz} = 200 > C_c$ use (Eq. 3.7-10).

See statement in section C3.7.4 concerning partial restraint.

$$KL/r = 46.2 + 0.615 \times 200 = 169.2.$$

$$\text{Design Strength} = F_a \times A = \frac{286,000}{(169.2)^2} \times 0.777 = 7.8 \text{ kips.}$$

Change unsupported length to 4 ft 10-1/2 in.

$$L/r_{zz} = \frac{58.5}{0.586} = 100$$

For a two bolt connection:

$L/r_{zz} < C_c$: eccentric connection, both ends use Eq. 3.7-7.

$$KL/r = 60 + 0.5 \times 100 = 110; F_a = \left[1 - 0.5 \left(\frac{110}{152.5} \right)^2 \right] 24.6 = 18.2 \text{ ksi.}$$

$$\text{Design Strength} = F_a \times A = 18.2 \times 0.777 = 14.1 \text{ kips.}$$

EXAMPLE 11. Cold-Formed Lipped Angle (1 in. = 25.4 mm; 1 ksi = 6.89 MPa; 1 kip = 4,450 N)

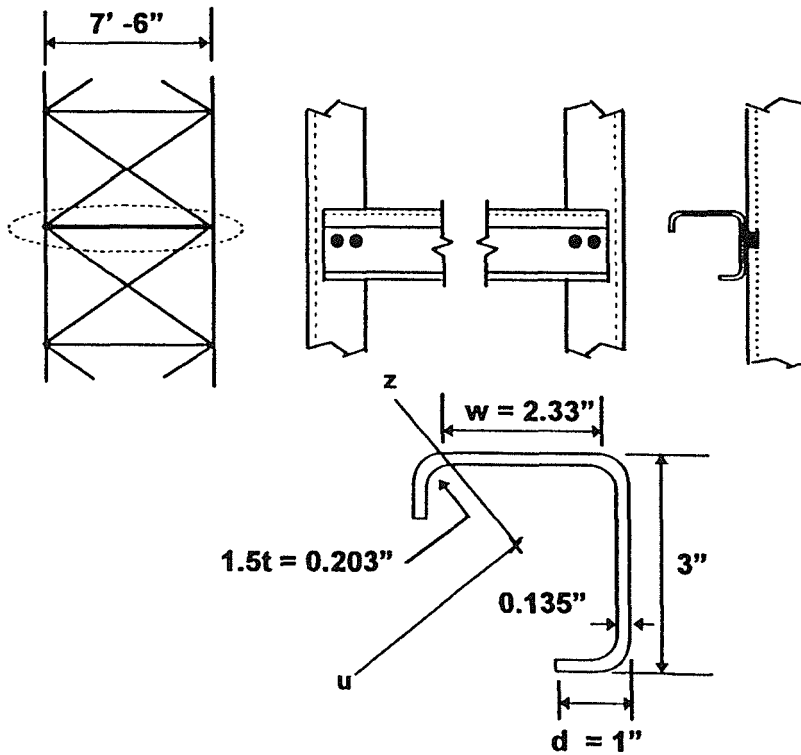

Tension-Only System with Compression Strut

$$F_y = 50 \text{ ksi, } C_c = 106.9, \left(\frac{w}{t} \right) \text{ lim} = \frac{220}{\sqrt{F_y}} = \frac{220}{\sqrt{50}} = 31.1 \quad \frac{w}{t} = \frac{2.33}{0.135} = 17.3 < 31.1$$

when $\sin \theta = 1$

$$d_{\min} = 2.8 t \sqrt[6]{\left(\frac{w}{t} \right)^2 - \frac{4000}{F_y}} = 2.8 \times 0.135 \sqrt[6]{(17.3)^2 - \frac{4000}{50}} = 0.93 \text{ in.} < d.$$

$A = 1.03 \text{ in.}^2$; $C_w = 0.441 \text{ in.}^6$; $\bar{u} = 1.34 \text{ in.}$; $I_u = 1.79 \text{ in.}^4$; $r_u = 1.32 \text{ in.}$; $m = 0.30 \text{ in.}$; $I_z = 0.616 \text{ in.}^4$;
 $r_z = 0.773 \text{ in.}$; $u_o = 1.34 + 0.30 = 1.64 \text{ in.}$; $I_{ps} = 1.79 + 0.616 + 1.03 \times 1.64^2 = 5.18 \text{ in.}^4$;
 $r_{ps} = 2.24 \text{ in.}$; $J = 0.00623 \text{ in.}^4$

$$r_t = \sqrt{\frac{0.441 + (0.04)(0.00623)(90)^2}{5.18}} = 0.689 \text{ in.}$$

$$\frac{2}{r_{yf}^2} = \frac{1}{0.689^2} + \frac{1}{1.32^2} + \sqrt{\left(\frac{1}{0.689^2} - \frac{1}{1.32^2}\right)^2 + 4 \left(\frac{1.64}{(0.689)(1.32)(2.24)}\right)^2} = 4.903$$

$$r_{yf} = \sqrt{\frac{2}{4.903}} = 0.639 \text{ in.} < r_{zz} \quad \frac{L}{r_{yf}} = \frac{90}{0.639} = 141 \text{ (two bolt connection. Eq. 3.7-10)}$$

$$\frac{KL}{r_{yf}} = 46.2 + 0.615 \times 141 = 133. \quad F_a = \frac{286,000}{(133)^2} = 16.2 \text{ ksi.}$$

Design Strength = $F_a \times A = 16.2 \times 1.03 = 16.7 \text{ kips.}$

EXAMPLE 12. M-Section as Column Member (1 in. = 25.4 mm; 1 ksi = 6.89 MPa; 1 kip = 4,450 N)

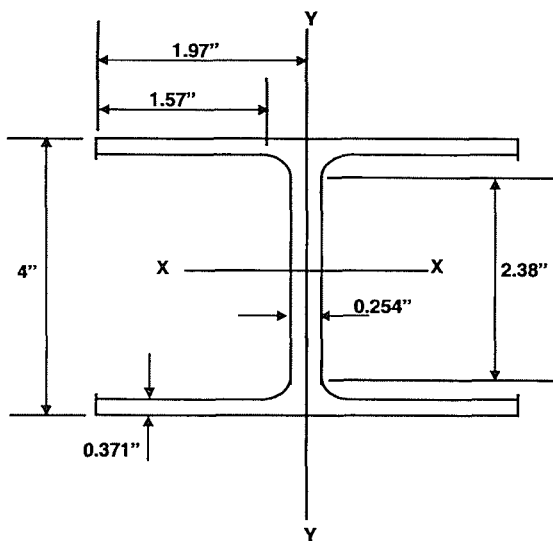

$M4 \times 13$; $F_y = 50 \text{ ksi}$; $C_c = 106.9$; $A = 3.81 \text{ in.}^2$; $r_y = 0.939 \text{ in.}$; $r_x = 1.66 \text{ in.}$; $J = 0.19 \text{ in.}^4$; $u_o = 0$;
 $I_x = 10.5 \text{ in.}^4$; $I_y = 3.36 \text{ in.}^4$; $S_x = 5.24 \text{ in.}^3$; $S_y = 1.71 \text{ in.}^3$; $K = 1$; $I_{ps} = 13.86 \text{ in.}^4$; $C_w = 11.06$.

Flange $w/t = 1.57/0.371 = 4.23$

Allowable $w/t = 72/\sqrt{50} = 10.2$

Web $w/t = 2.38/0.254 = 9.4$

Allowable $w/t = 220/\sqrt{50} = 31.1$

Local buckling of elements is not critical.

1. Determine column design strength, concentrically loaded; $L = 96 \text{ in.}$, $K_r = 1$

$$r_t = \sqrt{\frac{11.06 + (0.04)(0.19)(96)^2}{13.86}} = 2.419 \text{ in. (Eq. 3.8-2) } r_y = 0.939 \text{ in. } \therefore r_y \text{ controls}$$

$$L/r_y = 96/0.939 = 102.2 < C_c \therefore F_a = \left[1 - 0.5 \left(\frac{102.2}{106.9} \right)^2 \right] 50 = 27.15 \text{ ksi.}$$

Design Strength = $F_a \times A = 27.15 \times 3.81 = 103.4 \text{ kips}$

DESIGN OF LATTICED STEEL TRANSMISSION STRUCTURES

2. Determine if suitable for 50 kip load if member is connected on one flange at each end (eccentricity - 2.0 in.).

Use Eq. 3.12-1; $P_a = 103.4$ kips (prior calculations); $K_x = 1$; $L = 96$ in.; $K_y = 1$.

$$P_{ex} = \frac{\pi^2 EI_x}{(K_x L_x)^2} = \frac{3.14^2 (29,000)(10.5)}{96^2} = 326$$

$M_1 = M_2$ end moments; $C_m = 0.6 - 0.4(-1) = 1$.

$$\text{Eq. 3.14-1; } r^2 = \frac{1.0\sqrt{3.36}}{5.24} \sqrt{11.06 + (0.04)(0.19)(96^2)} = 3.15; r = 1.775 \text{ in.}$$

$$L/r = 96/1.775 = 54; F_a = \left[1 - 0.5 \left(\frac{54}{106.9} \right)^2 \right] 50 = 43.6 \text{ ksi.}$$

$$M_{ax} = F_a \times S_x = 43.6 \times 5.24 = 228.5 \text{ in.-kips; } M_{ay} = 0$$

$$\text{Eq. 3.12-1; } \frac{50}{103.4} + \frac{50 \times 2}{228.5} \times \frac{1}{1 - 50/326} = 0.484 + 0.515 = 0.999 < 1.0$$

Design Strength of member is 50 kips. (This illustrates the importance of minimizing eccentricities in end connections.)

EXAMPLE 13. Channel as Column (1 in. = 25.4 mm; 1 ksi = 6.89 MPa; 1 kip = 4,450 N)

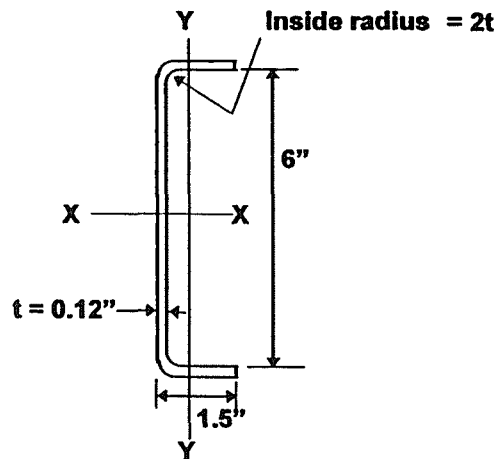

$I_x = 4.34 \text{ in.}^4$; $\bar{x} = 0.354 \text{ in.}$; $I_y = 0.239 \text{ in.}^4$; $m = 0.493 \text{ in.}$; $x_o = -(\bar{x} + m) = -0.847 \text{ in.}$;
 $J = 0.004 \text{ in.}^4$; $C_w = 1.37$; $r_x = 2.06 \text{ in.}$; $r_y = 0.48 \text{ in.}$; $r_{ps} = 2.28 \text{ in.}$; $I_{ps} = 5.3 \text{ in.}^4$; $A = 1.02 \text{ in.}^2$;
 $K = 1$; $F_y = 36 \text{ ksi}$; $C_c = 126$; $L = 48 \text{ in.}$

1. Determine column design strength for concentric load. Note: X-X is axis of symmetry.

$$\text{Eq. 3.8-2; } r_t = \sqrt{\frac{1.37 + (0.04)(0.004)(48)^2}{5.3}} = 0.57$$

Eq. 3.8-1; Terms use U-U as symmetrical axis. (Use X-X values in place of U-U values.)

$$\frac{2}{r_{ff}^2} = \frac{1}{0.57^2} + \frac{1}{2.06^2} + \sqrt{\left(\frac{1}{0.57^2} - \frac{1}{2.06^2} \right)^2 + 4 \left(\frac{0.847}{(0.57)(2.06)(2.28)} \right)^2}$$

$$\frac{2}{r_{ff}^2} = 6.23; r_{ff} = 0.57$$

$$r_y < r_x \text{ or } r_y L/r_y = 48/0.48 = 100; F_a = \left[1 - 0.5 \left(\frac{100}{126} \right)^2 \right] 36 = 24.7 \text{ ksi.} = f$$

Check flanges $w/t = 1.14/0.12 = 9.5$; Eq. 3.9-1 = $72/\sqrt{f} = 72/\sqrt{24.7} = 14.5$.

Check web $w/t = 5.28/0.12 = 44$; Eq. 3.9-3 = $220/\sqrt{f} = 220/\sqrt{24.7} = 44.3$.

Elements are fully effective. Design Strength = $F_a \times A = 24.7 \times 1.02 = 25.2$ kips.

2. Determine if channel is suitable for 8.7 kips load if connection is to back of web. End moments M_1 and M_2 are equal: $C_m = 1.0$;

Eccentricity about Y-Y axis = $e = 0.354 + 0.06 = 0.41$;

$S_{my} = 0.239/1.09 = 0.22$ (toe of flange).

$$M_{ay} = 36 \times 0.22 = 7.9 \text{ in.-kips; } P_{ey} = \pi^2 EI_y / (K_y L_y)^2 = \frac{(3.14)^2 (29,000)(0.239)}{48^2}$$

$M_{ax} = 0$; $P_{ey} = 29.7$.

$$\text{Eq. 3.12-1; } \frac{8.7}{25.2} + \frac{(8.7)(0.41)}{7.9} \left(\frac{1}{1 - 8.7/29.7} \right) = 0.35 + 0.64 = 0.99 < 1.0$$

Design Strength of member is 8.7 kips. (This illustrates the importance of minimizing eccentricities at the end connections.)

EXAMPLE 14. T-Section as Column (1 in. = 25.4 mm; 1 ksi = 6.89 MPa; 1 kip = 4,450 N)

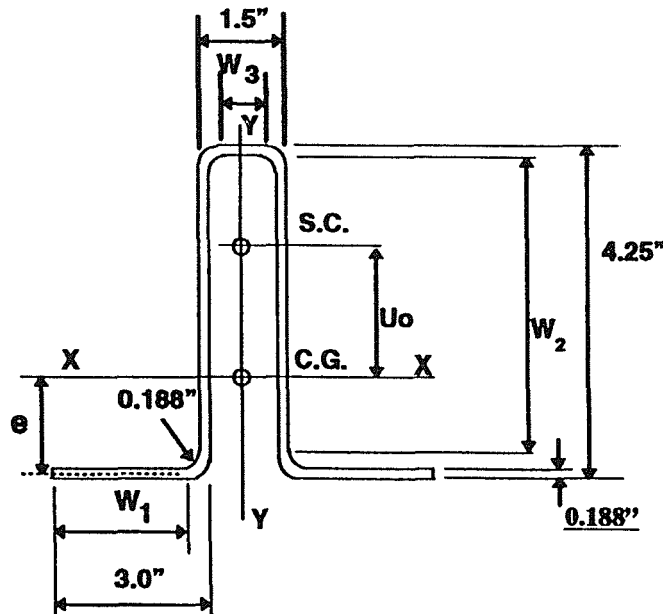

$u_o = -1.178$ in.; $I_y = 6.282$ in.⁴; $r_y = 1.504$ in.; $I_x = 6.168$ in.⁴; $r_x = 1.491$ in.; $r_{ps} = 2.423$ in.;
 $A = 2.775$ in.²; $F_y = 50$ ksi; $C_c = 106.9$; $C_w = 13.567$; $J = 0.0327$ in.⁴; $I_{ps} = 16.3$ in.⁴; $L = 120$ in.;
 $K = 1$; $e = 1.412$ in.

Determine Design Strength of concentric load.

$$\text{Eq. 3.8-2; } r_t = \sqrt{\frac{13.567 + (0.04)(0.0327)(120)^2}{16.3}} = 1.41 \text{ in.}$$

DESIGN OF LATTICED STEEL TRANSMISSION STRUCTURES

Eq. 3.8-1; Terms use $U-U$ as symmetrical axis. (Use $Y-Y$ values in place of $U-U$ values.)

$$\frac{2}{r_{yf}^2} = \frac{1}{1.41^2} + \frac{1}{1.504^2} + \sqrt{\left(\frac{1}{1.41^2} - \frac{1}{1.504^2}\right)^2 + 4\left(\frac{-1.178}{(1.41)(1.504)(2.42)}\right)^2}$$

$$\frac{2}{r_{yf}^2} = 1.407 \quad r_{yf} = 1.19 < r_x$$

$$L/r_{yf} = 120/1.19 = 100.8; \text{ Eq. 3.6-1.} \quad F_a = \left[1 - 0.5 \left(\frac{100.8}{106.9} \right)^2 \right] 50 = 27.7 \text{ ksi} = f$$

$w_2/t = 18.6$	Eq. 3.9-3	$220/\sqrt{27.7} = 41.8 > 18.6$
$w_3/t = 3.98$	Eq. 3.9-3	$220/\sqrt{27.7} = 41.8 > 3.98$
$w_1/t = 13.96$	Eq. 3.9-1	$72/\sqrt{27.7} = 13.68 < 13.96$

Maximum for $w_1 = 13.68 \times 0.188 = 2.572$ in. ($w_1 = 2.624$ in.)

New area = $2.775 - 2 \times 0.188 (2.624 - 2.572) = 2.775 - 0.020 = 2.755$ in.²

Design Strength = $F_a \times A = 27.7 \text{ ksi} \times 2.755 \text{ in.}^2 = 76.3$ kips.

EXAMPLE 15. Schifflerized Angle with Symmetrical Bracing (1 in. = 25.4 mm; 1 ksi = 6.89 MPa; 1 kip = 4,450 N)

Schifflerized angles are 90° hot-rolled angles that have had the legs closed to 60°. Properties of Schifflerized angles may be found in *Design Strength of Schifflerized Angle Struts* (Adluri and Madugula 1991).

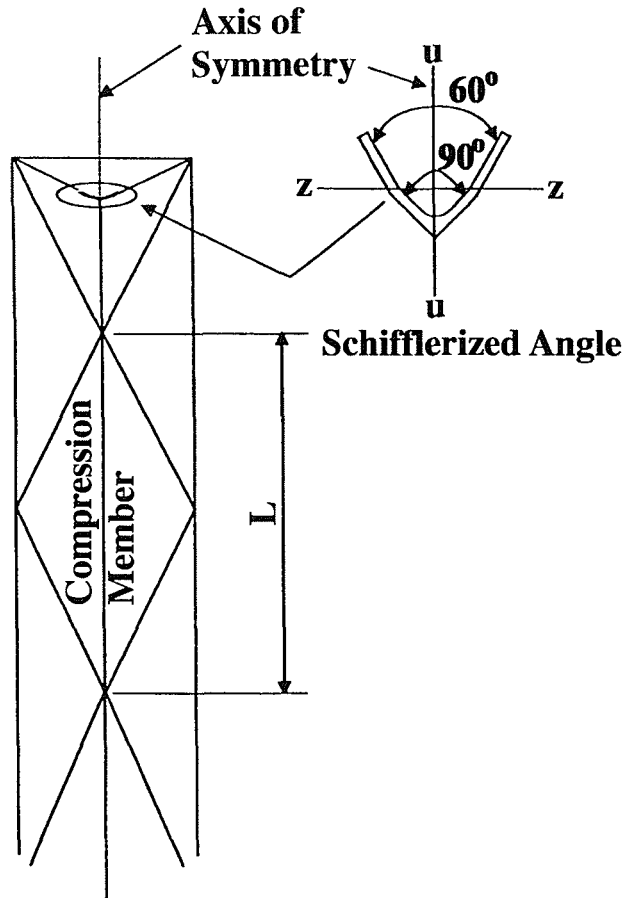

$L8 \times 8 \times 1/2$ (60°); $L = 9.0$ ft.; $F_y = 36$ ksi; $r_u = 2.40$ in.; $r_x = 1.83$ in.; $u_o = 3.58$ in.; $J = 0.646$ in.⁴; $C_w = 3.68$ in.⁶; $I_{ps} = 172$ in.⁴; $A = 7.75$ in.² Note: r_z for the 60° angle is not the commonly tabulated r_z for the hot-rolled shape.

$$\frac{w}{t} = \frac{8 - 1.125}{0.5} = 13.75; \quad \frac{w}{t_{lim}} = \frac{80}{\sqrt{36}} = 13.3; \quad \frac{w}{t} > \frac{w}{t_{lim}}$$

Failure modes include flexural buckling about the u and z axis and torsional-flexural buckling about the u axis. For torsional-flexural buckling assume the ends of the member are free to wrap at the panel points ($K_t = 1.0$). See Sections 3.7, 3.9.5, 3.8.3, and C3.8.

$$r_t = \sqrt{\frac{3.68 + 0.04(0.646)(1.0 \times 9.0 \times 12)^2}{172}} = 1.33 \text{ in.}; \quad r_{ps} = \sqrt{\frac{172}{7.75}} = 4.71 \text{ in.}$$

$$\frac{2}{r_{tf}^2} = \frac{1}{(1.33)^2} + \frac{1}{(2.4)^2} + \sqrt{\left(\frac{1}{(1.33)^2} - \frac{1}{(2.4)^2}\right)^2 + 4 \left(\frac{3.58}{(1.33)(2.40)(4.71)}\right)^2}; \quad r_{tf} = 1.21$$

$$\text{For } K = 1.0, \quad \frac{KL}{r_u} = 45.0, \quad \frac{KL}{r_z} = 56.0, \quad \frac{KL}{r_y} = 88.8$$

$$F_{cr} = \left[1.677 - 0.677 \left(\frac{13.75}{13.3} \right) \right] 36 = 35.2 \text{ ksi}$$

$$C_c = \pi \sqrt{\frac{2(29,000)}{35.2}} = 127.5$$

$$F_a = \left[1 - 0.5 \left(\frac{88.8}{127.5} \right)^2 \right] 35.2 = 26.7 \text{ ksi}$$

$$\text{Design Strength} = 26.7 \text{ ksi} \times 7.75 \text{ in.}^2 = 206.9 \text{ kips.}$$

EXAMPLE 16. Schifflerized Angle with Unsymmetrical Bracing (1 in. = 25.4 mm; 1 ksi = 6.89 MPa; 1 kip = 4,450 N)

Schifflerized angles are 90° hot-rolled angles that have had the legs closed to 60°. Properties of Schifflerized angles may be found in *Design Strength of Schifflerized Angle Struts* (Adluri and Madugula 1991).

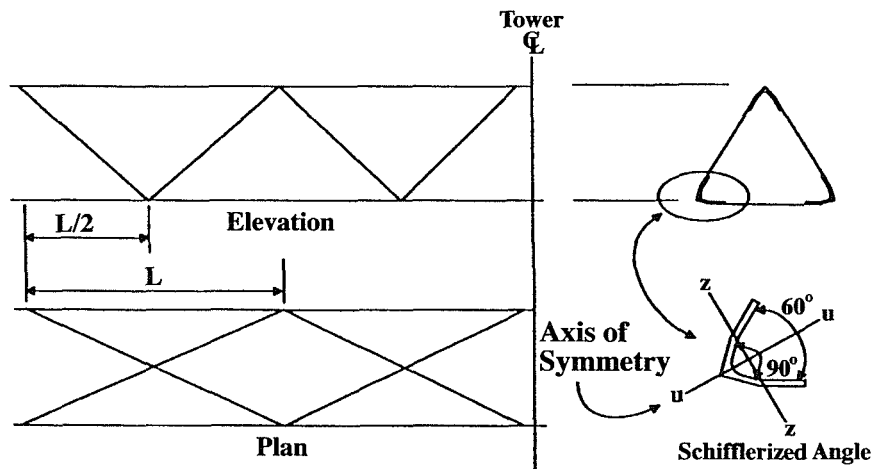

Lower Cord Member of a Triangular Tower Bridge

Failure modes include flexural buckling about the u and z axis and torsional-flexural buckling about the u axis. For torsional-flexural buckling assume the ends of the member are free to wrap at the panel points ($K_t = 1.0$). Since the panel points are staggered assume the warping length is based on $L/2$ and solve based on the mixed end condition. Note: r_z for the 60° angle is not the commonly tabulated r_z for the hot-rolled shape.

$L6 \times 6 \times 3/8$ (60°); $L = 9.0$ ft.; $F_y = 36$ ksi; $r_u = 1.84$ in.; $r_z = 1.44$ in.; $u_o = 2.71$ in.; $J = 0.204$ in.⁴; $C_w = 0.698$ in.⁶; $I_{ps} = 55.7$ in.⁴; $A = 4.36$ in.²

$$\frac{w}{t} = \frac{6 - 0.875}{0.375} = 13.7; \quad \frac{w}{t_{\text{lim}}} = \frac{80}{\sqrt{36}} = 13.3; \quad \frac{w}{t} > \frac{w}{t_{\text{lim}}}$$

$$r_t = \sqrt{\frac{0.698 + 0.04(0.204)((1.0 \times 0.5) \times 9.0 \times 12)^2}{55.7}} = 0.663 \text{ in.}; \quad r_{ps} = \sqrt{\frac{55.7}{4.36}} = 3.57 \text{ in.}$$

$$\frac{2}{\left(\frac{r_{gf}}{K'}\right)^2} = \frac{1}{\left(\frac{r_t}{K_t}\right)^2} + \frac{1}{\left(\frac{r_u}{K_u}\right)^2} + \sqrt{\left(\frac{1}{\left(\frac{r_t}{K_t}\right)^2} - \frac{1}{\left(\frac{r_u}{K_u}\right)^2}\right)^2 + 4\left(\frac{u_o}{\left(\frac{r_t}{K_t}\right)\left(\frac{r_u}{K_u}\right)(r_{ps})}\right)^2}$$

Note: r/K values are discussed in Section C3.8.

$$\frac{2}{\left(\frac{r_{gf}}{K'}\right)^2} = \frac{1}{\left(\frac{0.663}{1.0 \times 0.5}\right)^2} + \frac{1}{\left(\frac{1.84}{1.0}\right)^2} + \sqrt{\left(\frac{1}{\left(\frac{0.663}{1.0 \times 0.5}\right)^2} - \frac{1}{\left(\frac{1.84}{1.0}\right)^2}\right)^2 + 4\left(\frac{271}{\left(\frac{0.663}{1.0 \times 0.5}\right)\left(\frac{1.84}{1.0}\right)(3.57)}\right)^2}$$

$$\frac{K'}{r_{gf}} = 0.878$$

$$\frac{L}{r_u} = \frac{9 \times 12}{1.84} = 58.7; \quad \frac{L}{r_z} = \frac{0.5(9) \times 12}{14.4} = 37.5; \quad \frac{KL}{r_{gf}} = 9 \times 12 \times 0.878 = 94.8.$$

Since the load in the member will be changing at each end of the panel and normal framing eccentricities apply use Eq. 3.7-7.

$$\begin{aligned} \frac{KL}{r_{gf}} &= 60 + 0.5(94.8) = 107.4 \\ F_{cr} &= \left[1.677 - 0.677 \left(\frac{13.7}{13.3} \right) \right] 36 = 35.3 \text{ ksi} \\ C_c &= \pi \sqrt{\frac{2(29,000)}{35.3}} = 127.3; \quad \frac{KL}{r_{gf}} < C_c \\ F_a &= \left[1 - 0.5 \left(\frac{107.4}{127.3} \right)^2 \right] 35.3 = 22.7 \text{ ksi.} \end{aligned}$$

Design Strength = 22.7 ksi \times 4.36 in.² = 99.0 kips.

INDEX

- Allowable bending moments 11–14, 36–37
- Analysis, methods of 26–30
- Anchor bolts 9–10, 21–23, 45–46
- Anchorage requirements 18, 20–22, 45–46
- Angle members 3–6, 9, 12–14, 32, 61–63, 67–69
- Angle shear connectors 21, 24, 46
- Attachment holes 16, 41–42
- Attachment plates 42
- Axial compression and bending 10–11, 36
- Axial tension and bending 11, 36
- Axially-loaded compression members 3, 34

- Base assembly 20–23
- Beam webs 14, 37
- Beams 11–14, 36–37
- Bending moments 11–14, 36–37
- Bending operations 18
- Bills of material 16
- Block shear 1, 9, 10
- Bolt holes; diameter 9, 41–42; spacing 9, 10, 16, 17, 39–41
- Bolts 1, 15, 37–38
- Braced systems under shear load 29
- Buckling 8, 9, 26, 31, 34

- Cables *see* Guys
- Chamfering 41–42
- Channel sections; beams 11, 36–37; compression members 8, 64–65
- Climatic conditions 25
- Closed cross sections 9, 17
- Cold bending 18
- Cold-formed steel 1, 2, 31, 36, 61–63
- Component testing 43
- Compression members; member design 3–9, 31–32; shortening 28; stitch bolt spacing 10
- Computer analysis 26, 28, 29
- Concentrically loaded compression members 4, 54, 57
- Concentrically loaded tension members 9
- Concrete and reinforcing steel 23, 45–46
- Conductors 25, 42
- Connections; design 15–16, 37–42; detailing 17; in foundations 21–24; and joint restraint 6; and member capacity 53; plate thickness 3; and subdivided panels 56; in tension members 9
- Construction and maintenance operations 17–18, 25
- Corrosion 22, 45
- Cross-sections 3, 33
- Cruciform sections; beams 11, 36–37; compression members 9

- Dead-end structures 25

- Deformed bars 1, 21–22, 23
- Design bearing stress 15, 38, 40
- Design bending stress 11–14, 36–37
- Design compressive stress 3–4, 6, 7, 31
- Design-factored loads 1, 2, 19, 25
- Design shear 14, 37
- Design tensile stress 9
- Design tension 10
- Design torsional-flexural buckling stress 8, 9
- Detail drawings 16
- Detailing 16–17
- Deterioration at ground level 22, 45
- Direct embedded structures 43
- Doubly symmetric open sections 8, 12
- Downthrust 1, 22
- Draw 17
- Drawings 16–17
- Dynamic analysis 29

- Eccentric connections 9
- Eccentrically loaded compression members 10–11, 36
- Edge distance 16, 37, 39, 40, 41
- Effective length 4–6, 32
- Effective width 7–8, 11, 34
- Elastic buckling stress 34
- Elements in compression 7–8, 34
- Elements with stress gradient 8
- End distance 15–16, 37, 38–40
- Engineer of record (EOR) 16–17
- Equal leg angles 4, 5, 12–13, 37, 52–53
- Erection drawings 16
- Examples 52–69

- Fabrication 17–18
- Failures in testing 17, 19
- Fasteners 1, 15, 37–38
- First-order linear elastic truss analysis 26
- Flexural buckling 8, 9, 31–32
- Foundations 20–24, 45–46

- Galvanized steel 1, 18
- Galvanizing 1, 17, 18
- Geometric configurations 2, 25–26
- Geometrically nonlinear elastic analysis 26
- Guyed structures 25, 26, 29–30
- Guys 10, 36

- Horizontal bracing 25–26
- Hot bending 18
- Hot-rolled steel; standards 1, 2; width to thickness ratio 3

- I sections 12, 37
- Insulator strings 25, 41, 44
- Joint restraint 6, 26
- Joints, locations of 26
- K-bracing 54–55
- Laterally supported beams 11
- Latticed H-frames 29–30
- Layout drawings 16
- Leg members 1, 3, 4, 5, 21, 32
- Legislated loads, minimum 25
- Line security 1, 25
- Lips 7, 34, 62–63
- Load factor 1
- Load testing procedure 19, 44
- M-sections 63–64
- Masts, latticed 29–30
- Materials; anchorage 45; fasteners 15; for prototypes 18, 43; standards 2–3, 15; steel 17, 30–31
- Maximum bearing stress *see* Design bearing stress
- Member restraint determination 35
- Members, design of 2–14, 30–37
- Minimum embedment 23
- Minimum lip depth 7
- Minimum thickness, steel 3, 22, 31
- Model, simplified 27
- Nonsymmetric cross-sections 9, 34
- Nuts 1, 15
- Piece marks 18
- Piers; concrete 20; reinforcing of 46
- Point-symmetric open cross-sections 9
- Post-buckling member behavior 26, 34
- Pressed plate foundations 20, 21, 45
- Primary members 1, 26
- Proof testing 18–20, 42–45
- Prototypes 18–20, 43–45
- Quality assurance/quality control 24, 46–47
- Radius of gyration 6, 7, 34, 36
- Redundant members; defined 1, 26; effective length 5; end distances 38; loads 32; slenderness ratio 3
- Reinforced concrete *see* Concrete and reinforcing steel
- Schifflerized angles 67–69
- Seal welds 17, 18
- Second-order elastic analysis 26
- Section properties; beams 11; general 3, 31
- Shear connectors 21, 24, 46
- Shear friction 2, 21, 22, 23, 45
- Shipping 18
- Shop check assembly 17
- Shop detail drawings 16–17, 47
- Shop operations 17–18
- Shortening and compressive force 28
- Singly symmetric open sections 8, 12, 37, 65–66
- Slenderness ratios 3, 10, 31
- Smooth bars 22, 23
- Snug-tight joints 2
- Soil properties 43
- Standards 1, 2
- Steel grillages 20–21
- Stitch bolts 10
- Strain measurements 43–44
- Strain structures 25
- Stress gradients 8, 34
- Structural analysis *see* Analysis, Methods of
- Stub angles 21, 22–23, 45–46
- Stud shear connectors 24, 46
- Subpanel configurations 33, 56–57
- Suspension structures 25
- Symmetrical lipped angles 6–7, 34
- T sections 12, 37, 65–66
- Tension members 9–10, 36
- Tension-only members; defined 2; draw 17; slenderness ratio 3, 31; *vs.* tension-compression system 26, 28
- Test data, interpretation of 43
- Test loads 19
- Test reports 20
- Test verification 30–31
- Testing 18–20, 42–45
- Threaded rods 9–10
- Torsional buckling 8, 9, 34
- Torsional-flexural buckling 8, 31, 34
- Tower model 27
- Unfactored load 2
- Uniformly compressed elements 7–8
- Uplift 2, 22
- Vibration 31
- Weathering steel 17, 31
- Welding 1, 18
- Width to thickness ratio 3, 4, 7, 32, 34
- Wind 19, 31, 42
- X-bracing 58–61

Errata Sheet

Standard 10-97: Design of Latticed Steel Transmission Structures ISBN: 0-7844-0324-4

Page ix, title 3.6, "Design Compression Stress" should read "Design Compression"

Page xiv, Example 11, "Colded-Formed Lipped Angle" should read "Cold-Formed Lipped Angle"

Page 2, definition of snug-tight, "plies" should read "plies"

Page 4, Figure 3.1(b), The $2t^*$ thickness should be referenced to the inside edges of the channel flanges, (corrected figure shown below)

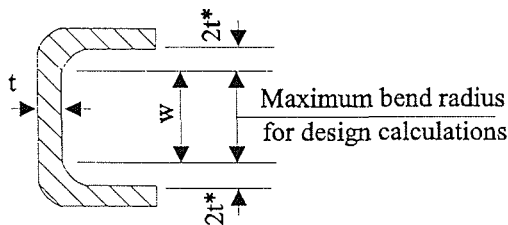

Page 12, Equation 3.14-4, should read $j = \left[\frac{1}{2Ix} \int_A (x^2 + y^2) y \, dA \right] - y_0$
(change "x dA" to "y dA")

Page 12, Equation 3.14-6, " M_c " should read " M_{yc} "

Pages 13 and 14, Equations 3.14-9, 3.14-10, and 3.14-11, " S_t " should read " S_z "

Page 16, Section 4.6, Equation 4.6-2, "135" should read "1.35"

Page 18, Section 5.2.3, second to last paragraph, "more the 1/32" should read "more than 1/32"

Page 29, top of right column, "EPA 1987" should read "BPA 1987"

Page 32, C3.7.4(b), "Figure C3.1" should read "Figure C3.3"

Page 34, C3.9.3, last paragraph, "(Figure C3.3)" should read "(Figure C3.1)"

Page 39, in the footnotes to Table C4.1, "Eq. 4.5.3 = 1 = d/2" should read "Eq. 4.5-3 = t + d/2"

Page 45, Section C6.11, "shall" should read "should"

Page 54, Example 3, in the references to the equations, "(Eq. 5.7-8)" should read "(Eq. 3.7-8)" and "(Eq. 5.7-10)" should read "(Eq. 3.7-10)"

Page 67, Example 15, " $r_x = 1.83$ " should read " $r_z = 1.83$ "

Page 68, Example 16, below the figure "Lower Cord" should read "Lower Chord"

Page 69, Example 16, The value of u_0 "271" in the equation after "Note: r/K values are discussed in Section C3.8." should read "2.71"